

ROLLER SUPPORT

Figure 333

The Figure 333 is designed for axial movement of pipe where vertical adjustment is required. This part is normally used directly above the supporting structure.

Material: Cast Iron Pipe Roll, Carbon Steel Axle, Chair, and Hex Nuts. Do not exceed 450° F / 232° C at the contact point to the roll.

Finish: Plain, Painted, Electro-Galvanized, Hot-Dip Galvanized.

For pipe with insulation and a pipe covering protection saddle the Figure 333 will have to be oversized to suit. Please see the Table for the Figure 142 which shows the correct sizing for insulated pipe.

Ordering: Specify pipe size, figure number, and finish. For Metric applications specify Figure M333.

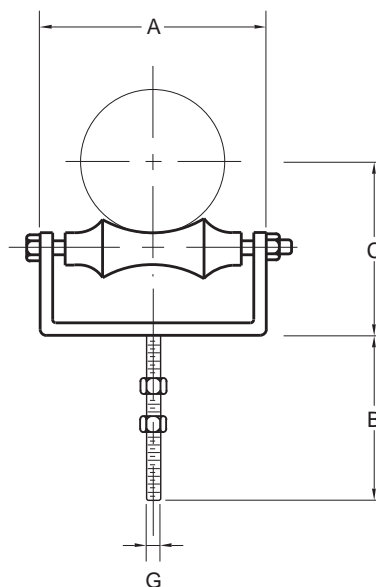

FIGURE 333 – ROLLER SUPPORT

PIPE SIZE	MAXIMUM LOAD	A	B	C	ROD G	WEIGHT EACH
2	400	2 $\frac{1}{8}$	6	2 $\frac{1}{8}$	$\frac{1}{2}$	2.09
50	1779	73	152	73	M12	0.95
2 $\frac{1}{2}$	400	3 $\frac{3}{8}$	6	3 $\frac{3}{8}$	$\frac{1}{2}$	2.43
65	1779	86	152	83	M12	1.10
3	400	4	6	3 $\frac{5}{8}$	$\frac{1}{2}$	2.65
80	1779	102	152	92	M12	1.20
3 $\frac{1}{2}$	400	4 $\frac{1}{2}$	6	4	$\frac{1}{2}$	2.72
90	1779	114	152	102	M12	1.23
4	600	5 $\frac{5}{8}$	6	4 $\frac{5}{16}$	$\frac{5}{8}$	3.43
100	2669	130	152	110	M16	1.56
5	600	6 $\frac{1}{8}$	6	5 $\frac{1}{16}$	$\frac{3}{4}$	4.26
125	2669	156	152	129	M16	1.93
6	900	7 $\frac{1}{4}$	6	6	$\frac{3}{4}$	7.71
150	4004	184	152	152	M20	3.50
8	900	9 $\frac{3}{8}$	6	7 $\frac{1}{4}$	$\frac{3}{4}$	9.93
200	4004	238	152	184	M20	4.50
10	1100	11 $\frac{1}{2}$	6	8 $\frac{13}{16}$	1	16.70
250	4893	292	152	224	M24	7.55
12	1100	13 $\frac{1}{2}$	6	10 $\frac{5}{16}$	1	19.30
300	4893	343	152	262	M24	8.77

DIMENSIONS		TEMPERATURE	LOADS	WEIGHT
INCHES	FAHRENHEIT	POUNDS	POUNDS	
MILLIMETERS	CELSIUS	NEWTONS	KILOGRAMS	