

ADJUSTABLE CHAIR AND ROLL

Figure 53

The Figure 53 is designed for longitudinal movement of pipe where vertical and lateral adjustment is required. The correct height can be obtained by adjusting the screws at each corner. The correct lateral location can be achieved by sliding the chair on the ends of the adjusting screws. The Figure 53 may be used without the Base Plate to rest on customer provided flooring or structure.

Material: Cast Iron Chair and Roll. Carbon Steel Axle, Base, and Adjusting Screws. Use a Figure 40 when a Carbon Steel Chair is required. Do not exceed 450° F / 232° C at the contact point to the roll.

Compliance: Federal Specification A-A-1192A Type 46, MSS-SP-69 Type 46.

Finish: Plain, Painted, Hot-Dip Galvanized.

For pipe with insulation and a pipe covering protection saddle the Figure 53 will have to be oversized to suit. Please see the Table below showing the correct sizing for insulated pipe.

Ordering: Specify chair number, figure number, and finish. For Metric applications specify Figure M53.

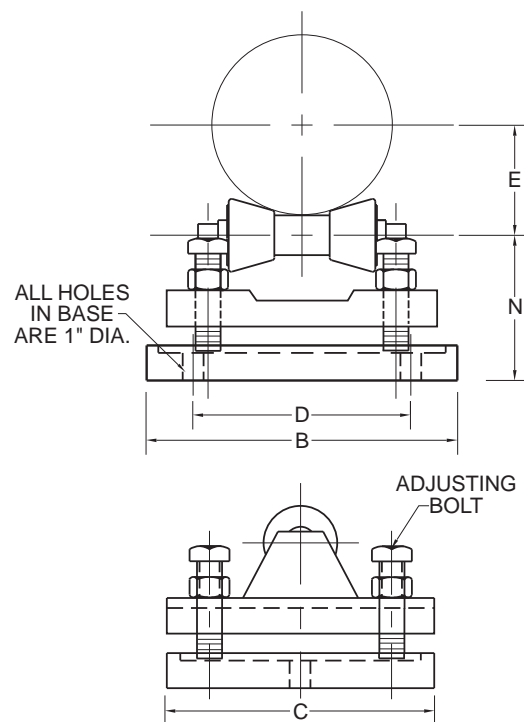

FIGURE 53 – ADJUSTABLE STEEL CHAIR AND ROLL

CHAIR NO.	MAX LOAD	BARE PIPE SIZE	B	C	D	E	N		WGT. EA.
							MIN.	MAX.	
1A	390	2	6 ⁷ / ₈	5 ¹ / ₂	3 ⁷ / ₈	1 ³ / ₄	3	3 ⁷ / ₈	15.5
		2 ¹ / ₂				2 ¹ / ₈			
		3				2 ¹ / ₂			
		3 ¹ / ₂				2 ¹ / ₂			
1A	1735	50	175	140	98	44	76	98	7.0
		65				54			
		80				64			
		90				64			
1	950	4	8 ¹ / ₂	5 ³ / ₄	5 ¹ / ₈	2 ⁷ / ₈	3 ³ / ₈	4 ¹ / ₂	20.7
		5				3			
		6				3 ⁷ / ₈			
1	4226	100	206	146	130	73	86	114	9.4
		125				76			
		150				98			
2	2100	8	10 ⁵ / ₈	7 ¹ / ₂	7 ³ / ₈	5 ³ / ₈	4 ⁷ / ₈	6 ⁵ / ₈	34.3
		10				6			
2	9342	200	270	171	187	137	124	168	15.6
		250				152			
3	3075	12	12 ¹ / ₂	8 ¹ / ₄	9 ¹ / ₂	7 ¹ / ₈	5 ⁷ / ₈	7 ⁷ / ₈	50.6
		14				8			
3	13679	300	333	203	241	181	149	194	23.0
		350				203			
4	4980	16	14 ⁵ / ₈	9 ¹ / ₄	11 ¹ / ₈	9 ¹ / ₄	5 ⁷ / ₈	7 ³ / ₄	73.6
		18				10 ¹ / ₂			
		20				11 ¹ / ₄			
4	22153	400	371	219	283	235	149	197	33.4
		450				267			
		500				286			
5	6100	24	15 ³ / ₄	9 ¹ / ₄	12 ¹ / ₄	13 ³ / ₈	6 ¹ / ₈	8	88.7
		600				340			
5	27135	600	400	219	311	340	156	203	40.2
6	7500	30	19 ¹ / ₄	11 ¹ / ₂	15 ³ / ₄	16 ⁷ / ₈	7 ¹ / ₄	10 ¹ / ₂	166
		750				429			
6	33363	750	489	267	400	429	184	267	75.3
7	12000	36	22 ¹ / ₂	13	16	20	8 ³ / ₈	11 ³ / ₄	233
		900				572			
7	53381	900	572	305	406	508	213	298	106
7	12000	42	22 ¹ / ₂	13	16	23 ³ / ₈	8 ³ / ₈	11 ³ / ₄	233
		1050				572			
7	53381	1050	572	305	406	587	213	298	106