

CHAIR AND ROLL

Figure 39

The Figure 39 is designed for longitudinal movement of pipe where vertical adjustment is not required. Because the chair is made of steel, it can be either welded or bolted in position

Material: Carbon Steel Chair and Axle with Cast Iron Pipe Roll. Use a Figure 17 when a Cast Iron Chair is required. Do not exceed 450° F / 232° C at the contact point to the roll.

Compliance: Federal Specification A-A-1192A Type 44, MSS-SP-69 Type 44.

Finish: Plain, Painted, Hot-Dip Galvanized.

For pipe with insulation and a pipe covering protection saddle the Figure 39 will have to be oversized to suit. Please see the Table below showing the correct sizing for insulated pipe.

Ordering: Specify chair number, figure number, and finish. For Metric applications specify Figure M39.

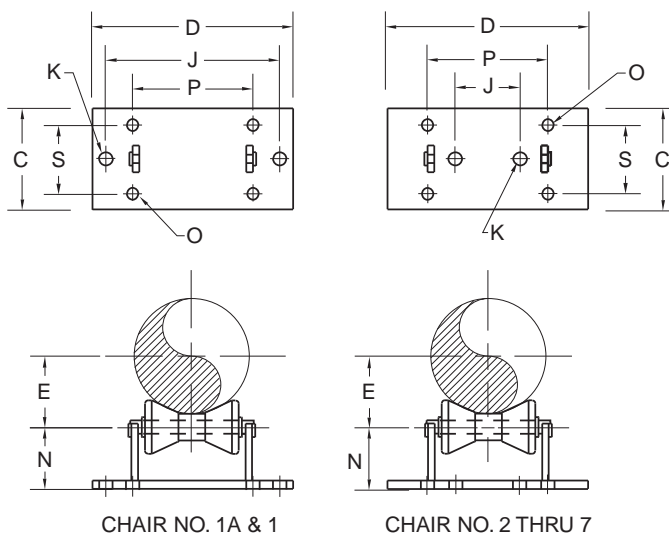

FIGURE 39 – CHAIR AND ROLL

CHAIR NO.	MAX LOAD	BARE PIPE SIZE	C	D	E	J	K	M	N	O	P	S	WGT. EA.
1A	390	2 2½ 3 3½	6	8½	1½ 1¾ 2½ 2¾	6½	1	¼	2	⅞	3½	4⅞	7.0
1A	1735	50 65 80 90	152	216	38 44 54 60	165	25	6	51	14	89	105	3.2
1	950	4 5 6	6	10⅞	2¾ 3¾ 3⅞	8	1	¼	2¾	⅞	4¾	4¼	10.5
1	4226	100 125 150	152	257	70 86 98	203	25	6	60	14	121	108	4.8
2	2100	8 10	7	9	5⅞ 6¼	4	1	⅜	3¾	⅞	7	5	16.5
2	9342	200 250	178	229	130 159	102	25	10	95	17	178	127	7.5
3	3075	12 14	8	11	7⅞ 8	5¾	1	⅜	4¾	⅞	9	6	26.8
3	13679	300 350	203	279	187 203	146	25	10	121	17	229	152	12.2
4	4980	16 18 20	9	12½	8⅞ 10 11	6¾	1	½	4¾	⅞	10	6½	40.5
4	22153	400 450 500	229	318	225 254 279	171	25	13	121	21	254	165	18.4
5	6100	24	8⅞	13¾	13	7½	1	⅝	4⅞	⅞	11½	6¾	51.0
5	27135	600	225	349	330	191	25	16	124	21	292	171	23.1
6	7500	30	11	17¼	16¼	10	1	⅝	5⅞	⅞	14¼	8	89.8
6	33363	750	279	438	413	254	25	16	143	21	362	203	40.7
7	12000	36 42	12	20	20 23⅞	12	1	1	5⅞	⅞	17	9	145
7	53381	900 1320	305	508	508 587	305	25	25	149	27	432	229	65.8

DIMENSIONS		TEMPERATURE	LOADS	WEIGHT
INCHES	FAHRENHEIT	POUNDS	POUNDS	
MILLIMETERS	CELSIUS	NEWTONS	KILOGRAMS	