

BALL VALVES

Gas/Fuel Shut-Off Valves

80-100 SERIES

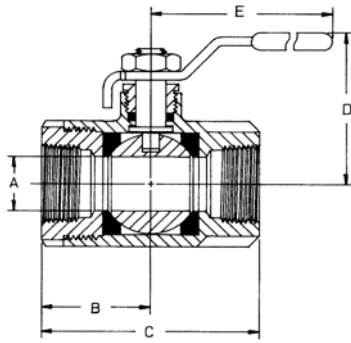
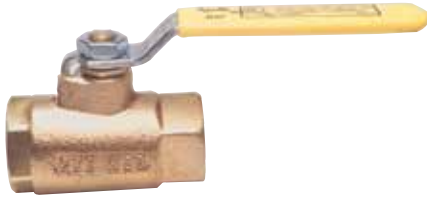

UL LISTED GAS SHUT-OFF VALVES

UL listed and designed as safe shut-off valve for LP gas, natural gas, flammable liquids and heated oil. Features easy quarter-turn ON/OFF, a large port to reduce pressure drop and NPT connections.

FEATURES

- RPTFE seats and seals
- Rated 600 psig CWP, non-shock
- 250 psig LP Gas
- Tee handle (-07)
- Latch lock handle (-27)
- Oxygen cleaned (-57)

UL LISTED

- YQNZ - UL1477
- YRBX - UL842
- YRPV - UL842
- YSDT - UL125
- MHKZ - UL842

Model Number	Size (in.)	Dimensions (in.)				
		A	B	C	D	E
80-101-01	1/4	0.37	1.03	2.06	1.75	3.87
80-102-01	3/8	0.37	1.03	2.06	1.75	3.87
80-103-01	1/2	0.50	1.12	2.25	1.81	3.87
80-104-01	3/4	0.68	1.50	3.00	2.12	4.87
80-105-01	1	0.87	1.68	3.37	2.25	4.87
80-106-01	1-1/4	1.00	2.00	4.00	2.62	5.50
80-107-01	1-1/2	1.25	2.18	4.37	2.87	5.50
80-108-01	2	1.50	2.34	4.68	3.06	5.50
80-109-01	2-1/2	2.50	3.25	6.50	4.12	8.00
80-100-01	3	2.50	3.37	6.75	4.12	8.00

Gas/Fuel Shut-Off Valves

90-100 SERIES

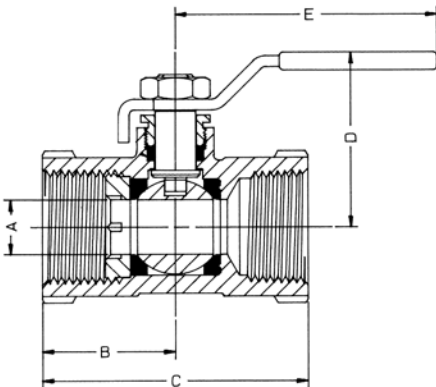

UL LISTED UNI-BODY THREADED BALL VALVE

A compact valve that's UL listed at 400 psig CWP, non-shock for fuel, inert gases and flammable liquids. Features ASTM Grade Bronze body, RPTFE seats and seals.

FEATURES

- Blowout-proof stem design
- One piece bronze body
- Optional tee handle (-07)
- Reduced port

UL LISTED

- YQNZ - UL1477
- YRBX - UL842
- YRPV - UL842

Model Number	Size (in.)	Dimensions (in.)				
		A	B	C	D	E
90-103-01A	1/2	0.37	1.14	2.15	1.68	3.87
90-104-01A	3/4	0.50	1.36	2.61	1.75	3.87
90-105-01A	1	0.62	1.50	2.90	2.00	4.87
90-106-01A	1-1/4	0.81	1.81	3.50	2.18	4.87
90-107-01A	1-1/2	1.00	2.06	3.79	2.62	5.50
90-108-01A	2	1.25	2.43	4.42	2.81	5.50