

# NON-ELECTRIC CONDENSATE PUMPS

## CARBON STEEL HIGH-CAPACITY TANK **PMPBP** Pressure Motive Pump

PUMPS

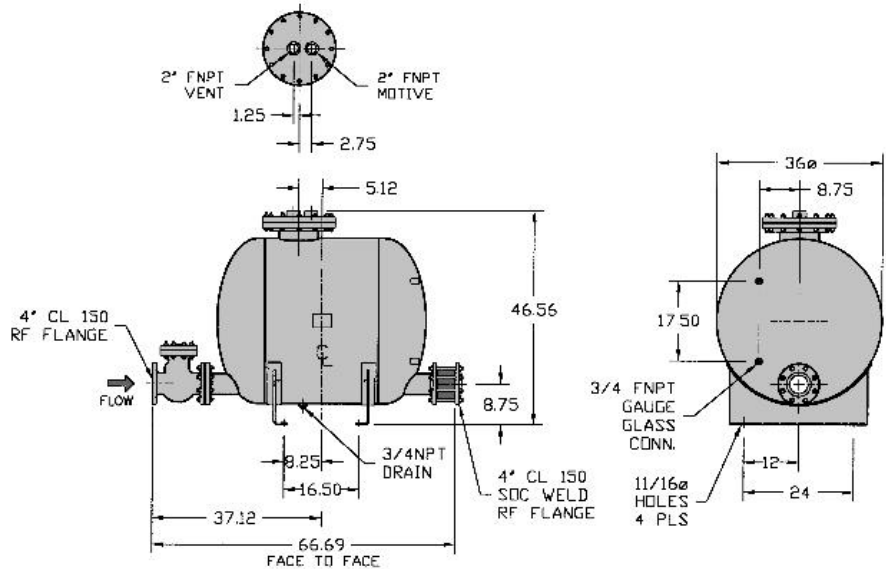

Model	<b>PMPBP</b>
Body	<b>Carbon Steel</b>
Cover	<b>Carbon Steel</b>
Check Valves	<b>Stainless Steel &amp; Steel</b>
PMO Max. Operating Pressure	<b>150 PSIG</b>
TMO Max. Operating Temperature	<b>366°F</b>
PMA Max. Allowable Pressure	<b>150 PSIG @ 470°F</b>

### MATERIALS

Body & Cover	<b>Carbon Steel</b>
Cover Gasket	Non-Asbestos
Cover Bolts	Steel
Inlet Valve	Stainless Steel
Vent Valve	Stainless Steel
Mechanism Yoke	304 Stainless Steel
Ball Float	304 Stainless Steel
Check Valves	Stainless Steel & Steel
Springs	Stainless Steel
Other Internal Components	Stainless Steel

### TYPICAL APPLICATIONS

The **PMPBP** is an *extremely high-capacity* pressure motive pump for applications requiring large transfer of condensate or other liquids. The internal operating mechanism functions identically to other pumps in the PMP series. **ASME "U" code stamp is available.**

### FEATURES

- All stainless steel internals for ultimate corrosion resistance
- Operates using steam, air, nitrogen or other pressurized gases as the motive force
- **Non-Electric** – can be used in remote locations or **NEMA 4, 7, 9 & hazardous areas**

### OPTIONS

- Cycle counter for measuring the amount of condensate flow through the pump.
- Insulation jackets are available to stop heat losses through the pump body.
- Sight glass for monitoring liquid level inside pump body.