

CHEMIQUIP DIAPHRAGM SEALS

Designed for the protection of pressure instruments in systems containing slurries, highly viscous or corrosive liquids or gases

- Completely protect both pressure instrument and snubber from:
 - corrosion
 - plugging
 - clogging
- Safeguard plant personnel
- Simplify initial system charging-eliminate spillage
- Smooth response of pressure-sensitive instruments to line surges or pulsations
- Snubber element is preset-it never needs adjustment
- Permit accurate equilibrium reading in 2-3 seconds
- For use on systems under vacuum as well as pressure

FACILITATE FILLING

The pourous snubbing element greatly simplifies initial charging of system. Its membrane will not pass liquids at extremely low pressure differences. The bourdon tube of the instrument can be filled completely, capped with the snubber, and righted without loss of the filling liquid.

INSTALLATION INSTRUCTIONS

1. Invert pressure gage; exacuate over oil to fill bourdon tube with low viscosity oil or other suitable material. With gage still inverted, cap gage connection with snubber. Gage may now be righted safely without spillage or loss of material from bourdon tube.
2. Fill upper chamber of diaphragm completely with oil or other suitable material. Assemble gage and snubber sub-assembly to diaphragm seal. If pressure is shown on instrument as a result of overfilling of system, zero instrument.

DIAPHRAGM SEALS

Chemiquip sealed system snubbers are equipped with diaphragm seals which are designed to suit the individual requirements of specific systems. To accomplish this with maximum economy and ease, a variety of configurations are available. The diaphragm seals are fabricated of varying materials to meet specific conditions of corrosion, heat or mechanical strength.

TYPE 100

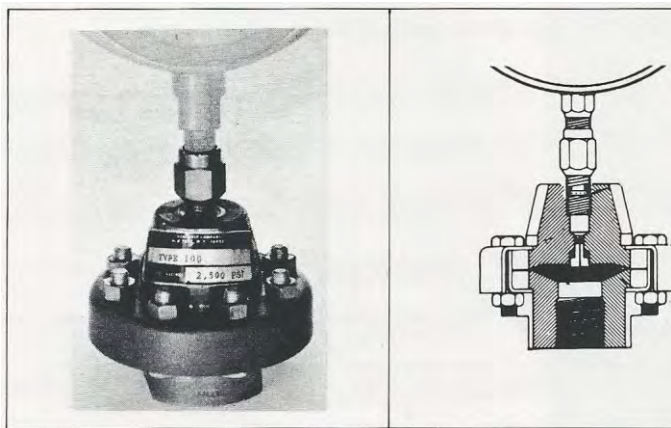

This sealed system snubber is indicated where extremely accurate response is required; or where it is desirable to disassemble the diaphragm seal for cleaning purposes. This ability is particularly important where it is being used on materials highly contaminated with solids inclusions which might tend to pack under the diaphragm.

CONSTRUCTION

Type 100 consists of a two-piece housing, bolted together at its periphery, which is separated into two chambers by a "capsule type" diaphragm. Consisting of two thin, metallic sections firmly welded at their periphery, this type "capsule type" diaphragm prevents flow of corrosive materials into the upper chamber of the diaphragm seal. A threaded connection attaches it firmly to the pressure instrument system. The diaphragm seal may be separated to facilitate cleaning without loss of filling material from the instrument. Having a small volumetric capacity and being fabricated of very thin membranes, the "capsule type" diaphragm can achieve accurate response to minute pressure changes in the system.

The upper chamber (A) of the diaphragm seal is forged mild steel. Stainless steel and other corrosion-resistant material are available for corrosive atmospheres. The lower chamber (B) is a forged type 316 stainless steel. It is suited to all pressures from vacuum through maximum of 2,500 psi.

TYPE 101

This type is particularly desirable for use on deao systems.

The diaphragm seal in Type 101 is the same as Type 100 except for the addition of a flushing connection in the lower chamber. This connection makes it possible to flush the lower chamber and consequently clean it without disassembling the diaphragm seal.

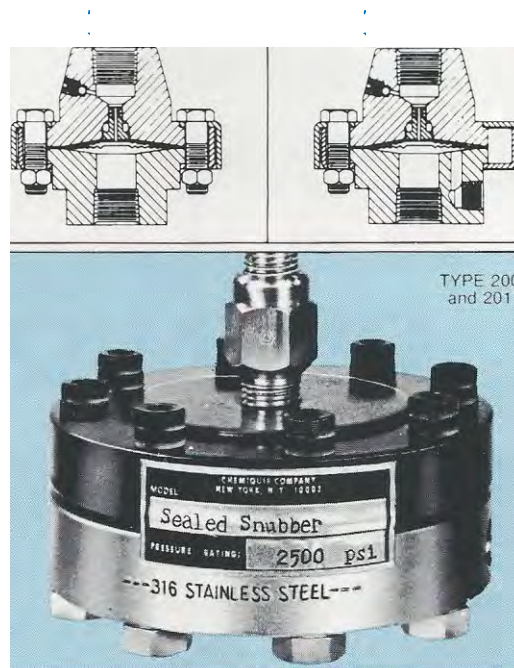

This economical sealed system snubber is ideally suited to applications involving the separation of the pressure instrument system from the pressure actuating material, where cleaning or purging of the lower chamber is not of importance.

CONSTRUCTION

Type 200 is equipped with a diaphragm seal which consists of a housing, laterally bisected by a thin, metallic diaphragm.

The housing's upper chamber (A) is fabricated of cadmium-plated carbon steel, the lower (B) of type 316 stainless steel. Other materials are available on special order. The diaphragm (C) is a corrugated type 316 stainless steel water, .005" thick. Maximum operating pressure is 2,500 psi. at 300 °F (max.).

TYPE 201

Available on special order, Type 201 is identical to Type 200 except that the diaphragm is firmly welded to the upper chamber. Because the diaphragm serves only as a separating membrane, it is possible to use thinner diaphragm sections, resulting in more accurate response to minor pressure changes.

With the diaphragm firmly welded to the upper chamber, it is possible to separate the lower chamber from the upper without losing the filling material on the instrument side of the diaphragm seal. Mass spectrometer tests have proven no leakage through the weld. Maximum operating pressure is 2,500 psi.

