

STEAM TRAPS

WFT Series

Float & Thermostatic Steam Trap

Watson McDaniel reserves the right to change the designs and/or materials of its products without notice.
©2010 Watson McDaniel Company

Model	WFT
Sizes	3/4", 1", 1 1/4", 1 1/2", 2"
Connections	NPT
Body Material	Cast Iron
PMO Max. Operating Pressure	250 PSIG
TMO Max. Operating Temperature	Saturated Steam Temperature
PMA Max. Allowable Pressure	250 PSIG up to 450°F
TMA Max. Allowable Temperature	450°F @ 250 PSIG



WFT
3/4" & 1"



WFT
2"



WFT
1 1/4" & 1 1/2"

TYPICAL APPLICATIONS

PROCESS: The **WFT Series** float and thermostatic steam traps are used for HVAC and industrial process applications. The excellent air handling capabilities of these traps make them a better choice than bucket traps for applications requiring quick start-up. Used on unit heaters, textile machines, heat exchangers, and other process equipment.

HOW IT WORKS

Float and thermostatic steam traps have a float and thermostatic element that work together to remove both condensate and air from the steam system. The valve, which is attached to a float, rises and opens the valve when condensate enters the trap. Air is discharged through the thermostatic air vent to the outlet side of the trap. The thermostatic air vent closes when steam enters the trap.

FEATURES

- All stainless steel internals with hardened seat and wear parts
- In-line repairability is simplified by having all internals attached to the cover
- Welded stainless steel thermostatic air vent resists shock from water hammer. Live orifice air vent is available for superheated applications
- Excellent air handling capability allowing air to be discharged rapidly and steam to enter the system quickly during start-up
- F & T traps discharge condensate immediately as it is formed (no condensate will back-up into the system)

SAMPLE SPECIFICATION

The trap shall be of float and thermostatic design with cast iron body and in-line piping configuration. Thermostatic air vent to be welded stainless steel. All internals must be stainless steel with hardened seat area. Trap must be in-line repairable.

INSTALLATION

Isolation valves should be installed with trap to facilitate maintenance. The trap must be level and upright for the float mechanism to operate. Trap must be sized and located properly in the steam system.

MAINTENANCE

Close isolation valves prior to performing any maintenance. All internal components can be replaced with the trap body remaining in-line. Repair kits include thermostatic air vent, float, valve seat and disc, and gaskets. For full maintenance details see Installation and Maintenance Manual.

OPTIONS

Live orifice air vent for superheated steam applications.

WFT Series

Float & Thermostatic Steam Trap

Dimensions: inches

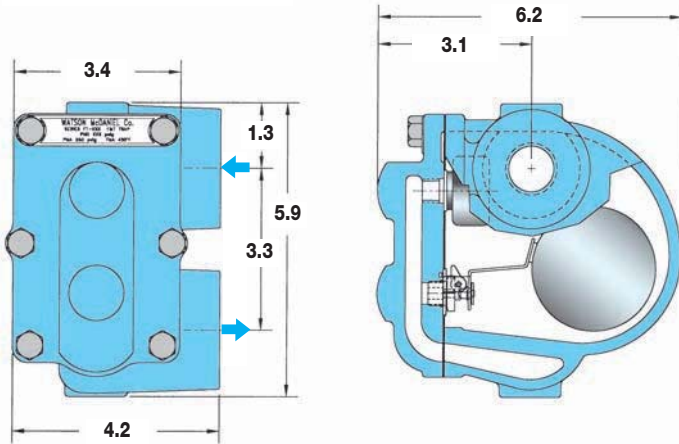

SPECIFICATIONS

Model	Sizes	Connection	PMO (PSIG)	PMA (PSIG)	Weight (lbs)
WFT-15	3/4", 1", 1 1/4"	NPT	15	125	9
WFT-30	3/4", 1", 1 1/4"	NPT	30	125	9
WFT-75	3/4", 1"	NPT	75	125	9
WFT-125	3/4", 1"	NPT	125	125	9

Dimensions: inches

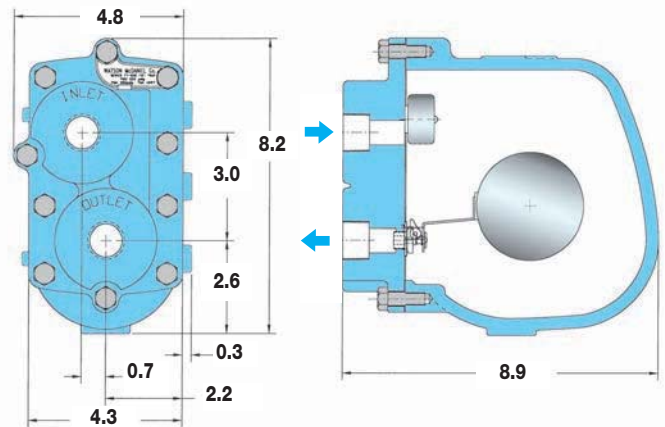

SPECIFICATIONS

Model	Sizes	Connection	PMO (PSIG)	PMA (PSIG)	Weight (lbs)
WFT-175	3/4", 1", 1 1/4"	NPT	175	250	20
WFT-250	3/4", 1", 1 1/4"	NPT	250	250	20

Dimensions: inches

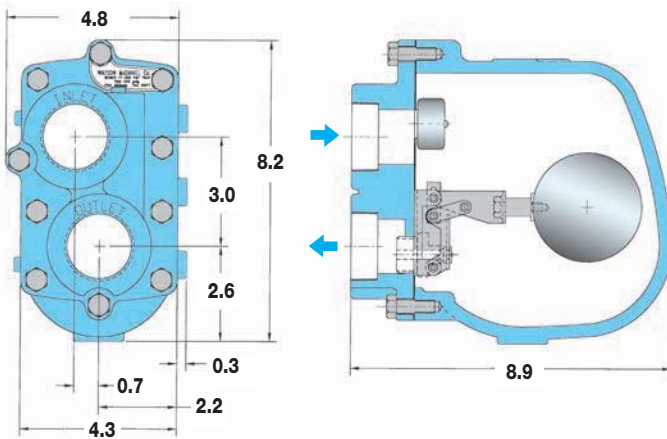

SPECIFICATIONS

Model	Sizes	Connection	PMO (PSIG)	PMA (PSIG)	Weight (lbs)
WFT-15	1 1/2"	NPT	15	250	21
WFT-30	1 1/2"	NPT	30	250	21
WFT-75	1 1/4", 1 1/2"	NPT	75	250	21
WFT-125	1 1/4", 1 1/2"	NPT	125	250	21
WFT-175	1 1/4", 1 1/2"	NPT	175	250	21
WFT-250	1 1/4", 1 1/2"	NPT	250	250	21

Dimensions: inches

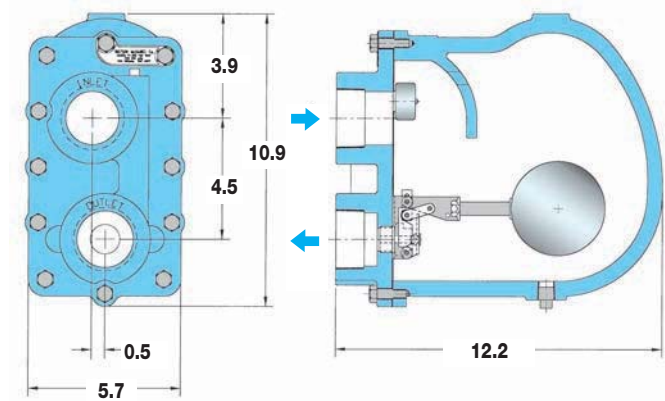

SPECIFICATIONS

Model	Sizes	Connection	PMO (PSIG)	PMA (PSIG)	Weight (lbs)
WFT-15	2"	NPT	15	250	53
WFT-30	2"	NPT	30	250	53
WFT-75	2"	NPT	75	250	53
WFT-125	2"	NPT	125	250	53
WFT-175	2"	NPT	175	250	53
WFT-250	2"	NPT	250	250	53