

FLAT GLASS BOILER VALVES

FORGED STEEL GAUGE VALVE

For Steam** Pressure up to 1500 PSI

The steel valve is lever-operated, outside screw and yoke design, and is recommended for steam service up to 1500 PSI @ 600°F. Forged steel body to ASTM A105 specification. Supplied with 303 SS and 420F replacement seat. Stem and nipple packing rings are secured by identical two-bolt packing yokes. Quadruple stem thread permits full open or shut position in one-quarter turn. Bronze stem bushing prevents seizing, and is located outside of valve body, thus unaffected by high temperature or corrosive fluids. Bottom of lower valve contains 1/2" pipe tap and female socket weld connection for gauge blowdown.

The EFI SG854 valves have 3/4" male pipe connections, while the EFI SG860 valves are fitted with ASME 3/4" 900# RF* flanges. EFI SG855 valves have the same connections as the EFI SG854, but feature a union connection on the tail piece. Special connections can be furnished on request.

Complete set includes two 5-foot lengths of chain, with handles to indicate open or closed position of valves, as required by the ASME Boiler Code.

When ordering: Specify Ernst Flow Industries Model number, 3/4" threaded or flanged connection. Specify gauge centers, operating pressure and temperature.

****WARNING: For use with POWER BOILER SATURATED STEAM APPLICATIONS ONLY. MODEL EFI SG STEEL GAUGE VALVES ARE NOT TO BE USED WITH SUPERHEATED STEAM.**

GRAPHITE PACKING CARTRIDGES	
PART NUMBER	DESCRIPTION
EFI SG854-4	Operating Stem
EFI SG854-5	Gauge End Stem

*300 or 600 lb. flanges optional



3/4" Threaded Connection
EFI SG854

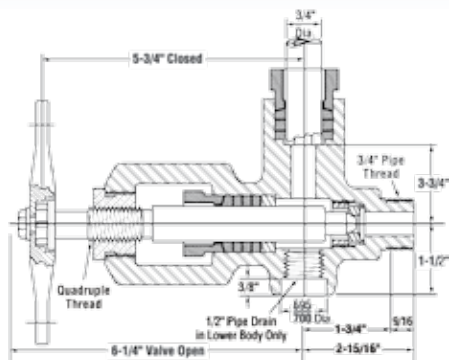

3/4" Threaded Union
EFI SG855

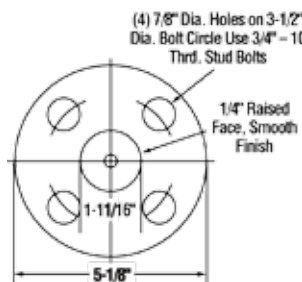
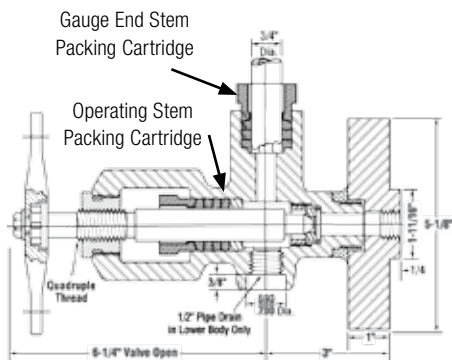
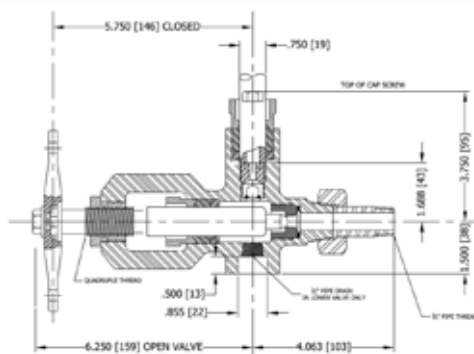

Flanged Connection
EFI SG860

MODEL	CONNECTION SIZE & TYPE	BALL CHECK LOWER	BALL CHECK UPPER	UNION	GAGE CONNECTION	MAX. PRESSURE	APPROX. WEIGHT PER SET (LBS.)
EFI SG854	3/4" NPT Male	No	No	No	3/4" OD Nipple	1500 PSIG	15
EFI SG855	3/4" NPT Male	Yes	Yes	Yes	3/4" OD Nipple	1500 PSIG	16
EFI SG860	3/4" 900# RF*	No	No	No	3/4" OD Nipple	1500 PSIG	25

*300 or 600 lb. flanges optional