

FLAT GLASS BOILER GAUGES

CLEAR FLAT GLASS BOILER WATER GAUGES

For Steam* Pressure up to 900 PSI @ 534°F
With Mica Shield

Heat-treated flat glass with mica protection makes this Ernst Flow Industries Gauges an efficient, boiler water level indicator. Finest quality borosilicate glass of special composition to resist temperature shock is carefully tested for surface trueness and assembled with best quality sheet mica in heavy steel housing. The mica resists corrosive effects of steam and water. Clamping of the 900 PSI design features individual "fingers" which assemble easily and promote uniform bolt pressure to assure gasket tightness. The assembly is easily dismantled for cleaning and other maintenance. Window slot 1/2" wide provides a highly visible gauge reading which can be accentuated by using an Ernst Flow Industries illumination assembly. Made in single and multiple-window style to handle a wide range of visibility requirements. See table below.

MODEL	Visibility	Minimum Gauge Centers	Approx. Weight (lbs.)
SINGLE WINDOW INSERTS			
EFI FG904	6-5/8"	17	22
EFI FG905	7-3/4"	18	25
EFI FG906	9"	20	28
EFI FG907	10-1/8"	21	31
EFI FG908	11-3/4"	22	34
EFI FG909	12-1/2"	23	37
DOUBLE WINDOW INSERTS			
EFI FG966	15"	26	62
EFI FG977	17-1/2"	29	67
EFI FG988	20"	31	72
EFI FG999	21-1/2"	33	78

Minimum centers shown apply to use with EFI SG854, EFI SG855, or EFI SG860

Replacement Glass and Gaskets are illustrated on page 13.

***WARNING: For use with POWER BOILER STAURATED STEAM APPLICATIONS ONLY. MODEL EFI FG BOILER WATER GAUGES ARE NOT TO BE USED WITH SATURATED STEAM.**



Single Window Gauge Insert



Double Window Gauge Insert



Chamber: Steel Cover: Steel

Special inserts up to *1500 PSI @ 596°F upon request

Replacement End Stem (6" Long, Field Cut To Length) Part No: PG4-060

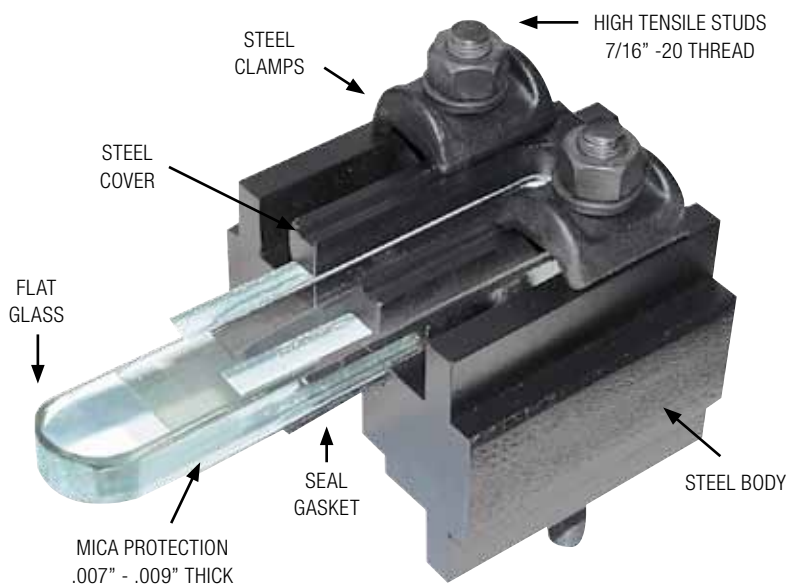

CROSS SECTIONAL VIEW

Spare Glass and Gaskets: See page 13

EFI DRUMLITE™

LED Illuminator For Flat Glass Boiler Water Gauges

- High Contrast
- Amber LED's for high intensity "star-like" image of water line
- Superior Visibility Day or Night
- Pays for itself in electricity savings alone!
- Field Upgradable
- Long Life ~ 100,000 hrs.
- Maintenance Free
- Power Supply: 120 or 240 VAC
- Electrical Connection: 3/4" FNPT
- Max Distance from Power Supply to Light Strip: 8 ft.
- Ambient Temperature: -40°F to 170°F
- Agency Approvals: FM and CFM (Canadian Use)
 - Class I, DIV 1, Groups B, C, and D
 - Class II, DIV 1, Groups E, F, and G
- Models for ordinary (non-hazardous) locations available