

# SVC/SHC Series

## Sanitary Check Valves

The patented SVC/SHC Series are vertical and horizontal check valves designed specifically for use in biopharmaceutical and parenteral drug manufacturing applications. They are the first check valves to follow the valve design guidelines of ASME BPE 2009. Since no spring, hinge, mechanical return mechanism or stem is used, they are crevice free, have no areas for particle entrapment, minimize particulate shedding, and are CIP and SIP capable, and autoclavable.

The SVC with Teflon, PEEK and 316/EPDM discs are for vertical up flow installations. The NEW SVC with floating Polypropylene disc was specifically designed for vertical downflow process outflow and drain installations, and is another Steriflow industry first. The SHC is designed with any disc for horizontal line installations.

### How it Works:

As soon as inlet pressure exceeds the weight of the disc plus the outlet pressure, the disc will lift. Process media flows under the seat and through the disc perimeter holes to the outlet side of the valve. As flow begins to reverse, the differential pressure across the valve drops and the disc returns to the seat, closing the valve.

### FEATURES

- NEW! DIN & ISO Tri-Clamp and tube weld ends - standard
- NEW - The first and only vertical down flow sanitary check valve that is continuously self draining
- Applicable for gas or liquids, and suitable for CIP and SIP, and are autoclavable
- Elimination of springs or hinges speeds opening time and eliminates particle entrapment areas
- High flow rates with minimal pressure loss compared with mechanical return check valves
- Low particle shedding properties compared with sliding disc type or spring return check valves
- Unique design eliminates dead space and crevices associated with spring check valves

**NEW - SVC for vertical down process outflow and drain installations**



- All wetted internal surfaces are mechanically polished and electropolished to SF5, 20 Ra  $\mu\text{in}$  (.5 Ra  $\mu\text{m}$ ), all external surfaces are 40 Ra  $\mu\text{in}$  (1 Ra  $\mu\text{m}$ ), electropolished, other finishes optional
- Sanitary tube weld ends and Tri-clamp ends available
- Positive shutoff without the use of a spring

### APPLICATIONS

- **NEW - SVC** for vertical down process outflow and drain lines
- WFI, USP PW: Pump outlet back flow prevention, POU back flow prevention
- Condensate drainage from clean steam distribution loops
- Condensate drainage from process systems using clean steam – fermenters, bioreactors, SIP systems and sterilizers
- Sampling systems in WFI and clean water supply systems
- Air pressure supply systems and pressure rinse systems in pharmaceutical piping
- To replace actuated diaphragm valves on some liquid mixing lines
- Gas ( $\text{O}_2$ ,  $\text{N}_2$ , CDA) sparge, purge or blanket applications
- Vacuum breaker (with filter) on vent line for vessels or equipment

**Patent, and Govt Registrations:** Patents: US PAT 6,823,893; EU Pat 1319878; Canada: CRN 13987.5



Steriflow by Jordan Valve

3170 Wasson Road • Cincinnati, OH 45209

513.533.5600 • 800.543.7311 • 513.871.0105 (f)

steriflow@richardsind.com • www.steriflowvalve.com

### SHC SERIES – FEATURES & BENEFITS

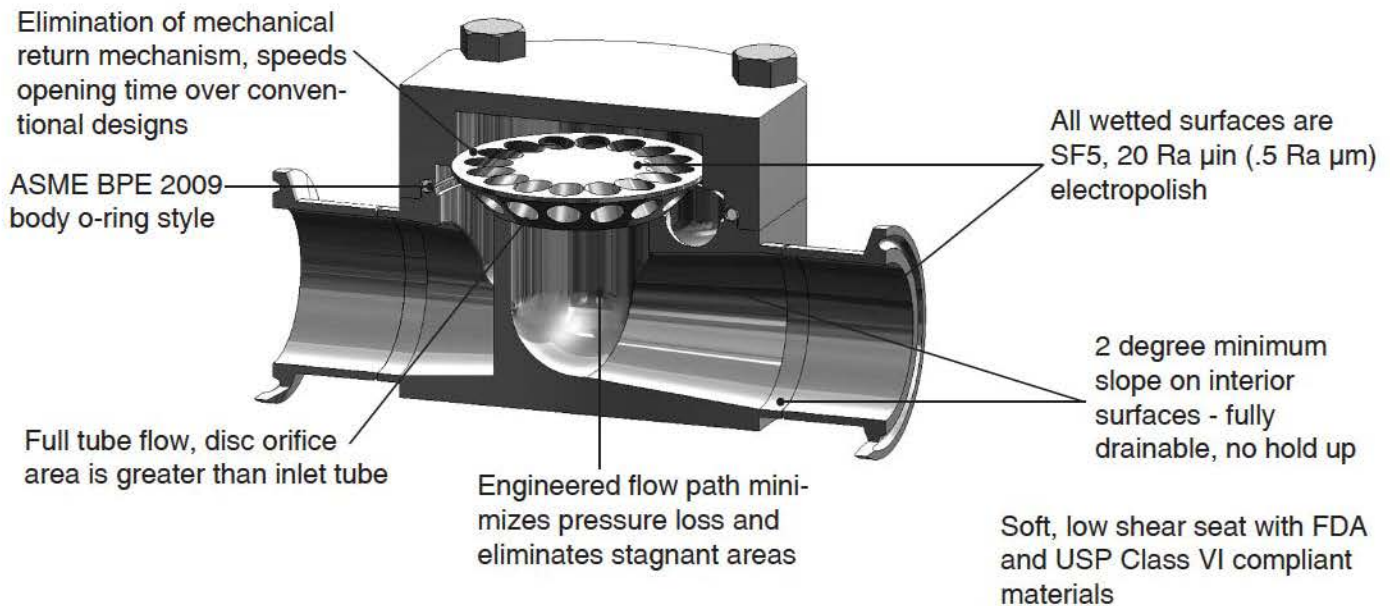

#### VERTICAL UPFLOW WITH TEFLON, PEEK, OR 316/EPDM DISC

#### NEW: VERTICAL DOWN FLOW WITH FLOATING POLYPROPYLENE DISC

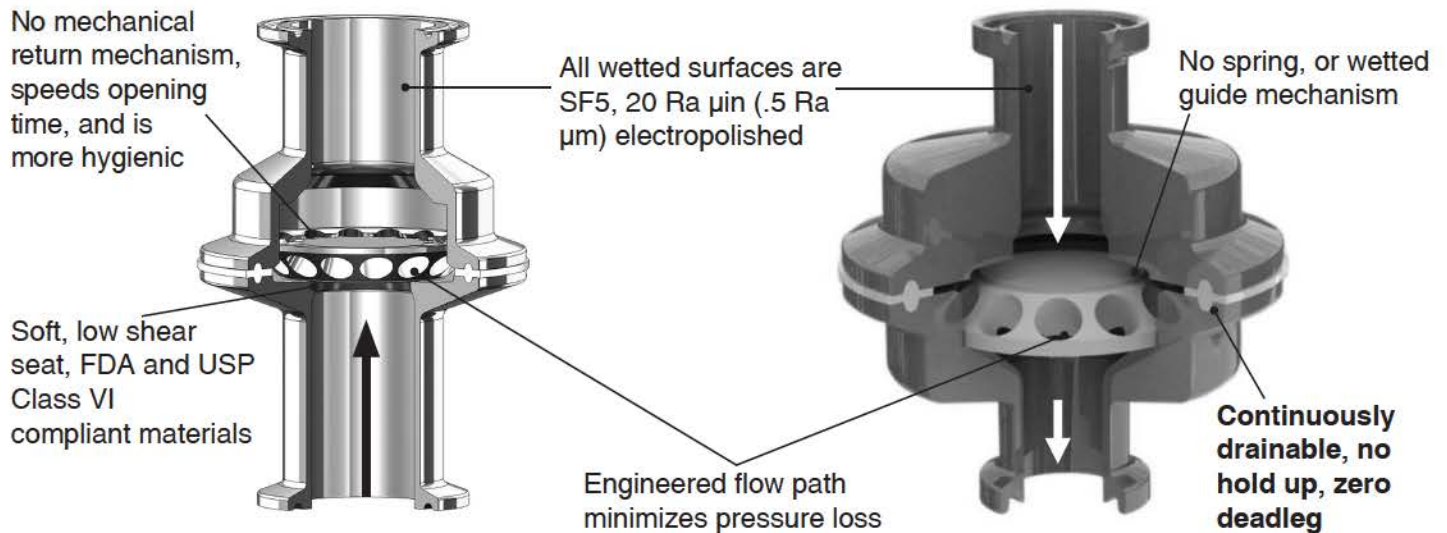

### SPECIFICATION

Steriflow Sanitary Check Valve, Model SVC for Vertical installation, Model SHC for Horizontal Installation. Body and end shall be constructed of bar stock material ASTM SA479 316L SF5, with internal wetted surfaces finished to Ra  $\mu\text{in}$  (0.5 Ra  $\mu\text{m}$ ) electropolished or better. Check valve shall use no internal springs or be guided, or slide in the wet (horizontal or vertical) by any means, to prevent particulate generation. Disc shall be constructed of ASTM SA479 316L, or other acceptable material with an EPDM seal, or manufactured out of solid Teflon®, Peek, or Polypropylene. All materials must be FDA and USP <88> Class VI. SVC Vertical down flow check valve shall be continuously drainable with no deadleg. SHC horizontal valves shall be completely drainable with no flat horizontal interior body wetted surfaces. Body sealing methods shall be bolted, or clamped and acceptable by ASME BPE 2009. All gasket materials, o-rings and seals shall be FDA and USP <88> Class VI compliant. Valve body shall be marked as per ASME BPE. Patents: US PAT 6,823,893, EU PAT 1319878

## SPECIFICATIONS

**Sizes**

- SVC: ASME BPE: 1/2" – 3"; DIN: DN15, DN20, DN25, DN40, DN50, DN65, DN80; ISO: DN15, DN20, DN25, DN40, DN50, DN65, DN80
- SHC: 1/2" – 2" (DIN DN15, DN20, DN25, DN40, DN50; ISO DN15, DN20, DN25, DN40, DN50)

**End Connections**

- ASME Tri-Clamp
- ASME Tube Weld Ends
- DIN/ISO Tri-Clamp Conn's to DIN 32676 Row A or B
- DIN/ISO Tube Weld Ends to DIN 11866 Row A or B

**Materials of Construction**

- Body: ASTM S A479 316L
- Disc: ASTM SA479 316/EPDM, solid Teflon, PEEK, or Polypropylene (All FDA and USP Class VI)
  - \* **Note: 2 1/2" and 3" (DN 65, DN80) Disc is not available in 316L/EPDM**
- SHC Body O-Ring: EPDM, Teflon, Silicone, Viton (All FDA and USP Class VI)
- SVC Body Gasket: Silverback®, Tuf-Steel®, TFE/Viton, TFE/EPDM, Viton-600S (All FDA and USP Class VI)

**Pressure/Temperature Rating**

- Max Pressure: 230 psi @ 100°F (16 bar @ 38°C)
- Max Temperature<sup>2</sup>: is dependent upon options selected

**Applications:** Bio or parenteral process, WFI, Clean Gases, Clean Steam<sup>2</sup>, Clean Condensate, CIP Fluids

**Opening Pressure**

- Polymer Discs: 0.04 psid (2,76 millibar)
- 316, 316/Elastomer: 0.13 psid (8,96 millibar)
- Polypropylene disc for Vertical Down installation is always open

**Surface Finish:** Internal wetted parts: ASME BPE SF5 (20 Ra  $\mu$ in (0.5 Ra  $\mu$ m) electropolished); External: 40 Ra  $\mu$ in (1 Ra  $\mu$ m) electropolished standard, 20 Ra and better optional

<sup>2</sup> Operation above 250°F (121°C) requires Option BC (Bolted Clamp for SVC) refer to Options 9 & 10 in the Ordering Schematic of the SVC on page 4. Maximum Pressure & Temperature is dependent upon gasket, or o-ring options selected. See order grids on page 4 for high temperature ratings at pressure for specific materials.

SHC SERIES PHYSICAL DATA

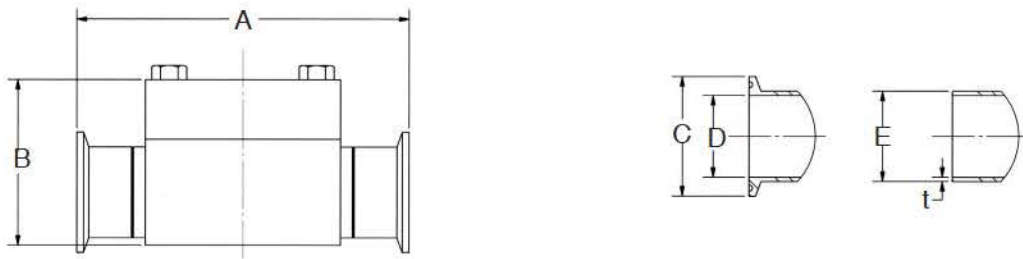

Valve Size	Dimensions (inches)						<sup>1</sup> Polymer discs Rev. Flow Leakage* 0.3 psi water ml/min	Max Cv	Wt Lbs
	A	B	C	D	E	t			
1/2"	4.00	2.09	0.984	0.375	0.50	0.065	0.6	3.4	3.3
3/4"	4.00	2.09	0.984	0.625	0.75	0.065	0.6	5.1	3.3
1"	4.00	2.09	1.984	0.870	1.00	0.065	1	6.6	3.4
1-1/2"	5.50	2.74	1.984	1.370	1.50	0.065	1	21.8	4.0
2"	6.30	3.25	2.516	1.870	2.00	0.065	0.8	23.1	4.1

\* Leakage is bubble-tight under same conditions at 30 psi

<sup>1</sup> 316/Elastomer disc leakage less than 0.1 ml/min

These dimensions apply only to US ASME BPE connections, consult factory for ISO and DIN dimensions

SVC SERIES PHYSICAL DATA

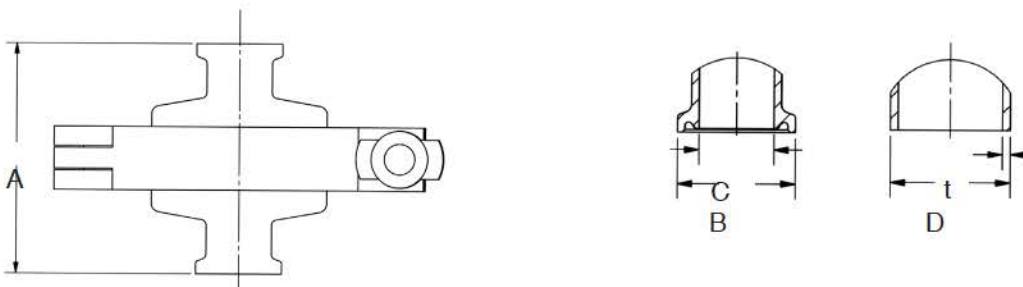

Valve Size	Dimensions (inches)					<sup>1</sup> Polymer discs Rev. Flow Leakage* 0.3 psi water ml/min	Max Cv	Wt Lbs
	A	B	C	D	t			
1/2"	2.67	0.984	0.375	0.50	0.065	1	3.5	2.0
3/4"	2.67	0.984	0.625	0.75	0.065	1	5.1	2.0
1"	2.67	1.984	0.870	1.00	0.065	1	7.1	2.1
1-1/2"	2.97	1.984	1.370	1.50	0.065	1	22.7	2.6
2"	3.27	2.516	1.870	2.00	0.065	0.8	23.1	2.7
2-1/2"	5.03	3.047	2.370	2.5	0.065	1.1	40.58	9
3"	5.03	3.580	2.875	3.00	0.065	1.1	58.06	9.1

\* Leakage is bubble-tight under same conditions at 30 psi

<sup>1</sup> 316/Elastomer disc leakage less than 0.1 ml/min

These dimensions apply only to US ASME BPE connections, consult factory for ISO and DIN dimensions

## SVC/SHC SERIES SANITARY CHECK VALVES

## SHC (HORIZONTAL) SERIES ORDERING SCHEMATIC

Model	—	Size	—	Body Mat'l	/	1	2	3	4	5	6

Model Number	
SHC	Standard

Size	
050	1/2" (DN15)
075	3/4" (DN20)
100	1" (DN25)
150	1-1/2" (DN40)
200	2" (DN50)

Body Material	
6L	ASTM A479, 316L

1 & 2	Body
TC	Tri-Clamp
TE	Tube End
TA	Tube Ends to DIN 11866 Row A
TB	Tube Ends to DIN 11866 Row B
TD	DIN Tri-Clamp to DIN 32676 Row A
TS	ISO Tri-Clamp to DIN 32676 Row B

3 & 4	Disc
TF	Teflon (FDA and USP Class VI)
S6	316L SST (1/2" - 1" valves only)
SE	316L/EPDM (FDA and USP Class VI) <sup>1</sup>
PK	PEEK (FDA and USP Class VI)
ZZ	Non-Standard

5 & 6	O-Ring
EP	EPDM <sup>1</sup>
SL	Silicone <sup>2</sup>
TF	Teflon <sup>2</sup>
VT	Viton <sup>2</sup>
ZZ	Non-Standard

<sup>1</sup> Disc rated to 275°F (135°C) at 230 psi (16 bar) with any disc; EPDM O-ring same limits with any disc.

<sup>2</sup> Rated to 350°F (176°C) with TFE disc, 400°F (204.4°C) with PEEK or 316SS disc, 275°F (135°C) with 316/EPDM disc. All ratings @ 230 psi (16 bar)

## SVC (VERTICAL) SERIES ORDERING SCHEMATIC

Model	—	Size	—	Body Mat'l	/	1	2	3	4	5	6

Model Number	
SVC	Standard

Size	
050	1/2" (DN15)
075	3/4" (DN20)
100	1" (DN25)
150	1-1/2" (DN40)
200 *	2" (DN50) bolted clamp (BC) only
250 *	2-1/2" (DN65) bolted clamp (BC) only
300 *	3" (DN80) bolted clamp (BC) only

Body Material	
6L	ASTM A479, 316L

1 & 2	Inlet Body
TC	Tri-Clamp to ASME BPE
TE	Tube End to ASME BPE
TA	Tube End to DIN 11866 Row A
TB	Tube End to DIN 11866 Row B (ISO)
TD	DIN Tri-Clamp to DIN 32676 Row A
TS	ISO Tri-Clamp to DIN 32676 Row B

3 & 4	Outlet Body
TC	Tri-Clamp to ASME BPE
TE	Tube End to ASME BPE
TA	Tube End to DIN 11866 Row A
TB	Tube End to DIN 11866 Row B (ISO)
TD	DIN Tri-Clamp to DIN 32676 Row A
TS	ISO Tri-Clamp to DIN 32676 Row B

5 & 6	Disc
TF	Teflon (FDA and USP Class VI) <sup>1</sup>
S6	316L SST <sup>2</sup> (1/2" - 1" valves only)
SE	316L/EPDM (1/2" - 2" only) (FDA and USP Class VI)
PK	PEEK (FDA and USP Class VI) <sup>4</sup>
PP*	NEW - Polypropylene (FDA and USP Class VI) <sup>5</sup>
ZZ	Non-Standard

<sup>1</sup> Rated 350°F (176°C), @ 230 psi (16 bar) for all gaskets, except TFE/EPDM, which is rated at 275°F (135°C) @ 230 psi (16 bar).

<sup>2</sup> Rated 400°F (204°C) @ 230 psi (16 bar) for all gaskets except TFE/EPDM, which is rated at 275°F (135°C) @ 230 psi (16 bar)

<sup>3</sup> Rated 275°F (135°C), @ 230 psi (16 bar), for all gasket materials

<sup>4</sup> Rated 450°F (232°C) @ 230 psi (16 bar) with Tuf Steel or Silverback gaskets; rated 400°F (204°C) @ 230 psi (16 bar); with any Viton gasket; Rated 275°F (135°C) @ 230 psi (16 bar); with TFE/EPDM gasket.

<sup>5</sup> Rated 176°F (80°C) @ 230 psi (16 bar) for all gaskets. Note: For SIP service, rated to 275°F (135°C) @ 30 psi (2 bar) for all gaskets.

\* Polypropylene is for SVC vertical downflow, drain applications.

7 & 8	Gasket
01	Silverback (FDA and USP Class VI)
02	TFE/Viton (FDA and USP Class VI)
03	TFE/EPDM (FDA and USP Class VI)
04	Viton-600S (FDA and USP Class VI)
05	TUF-Steel (FDA and USP Class VI)
ZZ	Non-Standard

9 & 10	Tri-Clamp
2P	2-Piece
3P	3-Piece
BC*	Bolted Clamp req for operation above 250°F (121°C)
ZZ	Non-Standard