

Mark 93TH Series

Sanitary Steam Traps

The Mark 93TH is a balanced port, thermostatic steam trap designed for use in validated clean steam systems that use threaded tube fittings or threaded tubing adapters for connections. The sanitary design includes a 20Ra µin finish on all internal wetted parts, self-draining design, and a compact size.

The MK93TH is designed with the same bellows as our MK93, and will therefore allow higher flow rates than competitive designs. Note: Low subcooling operation insures that condensate won't back up and wet (cool) the upstream validation temperature sensor.

There are two base designs within the MK93TH product range: the standard MK93TH – good for differential pressures (P1) up to 50 psi (3,4 bar), and the MK93TH Option "P" for the higher differential pressure associated with clean steam distribution drainage, or any application with pressure ranging from 45 – 90 psi (3,1 – 6,2 bar). Both designs are rated to 90 psi (6,2 bar) operating pressure but are recommended for use within the specified inlet pressure ratings.

Mark 93TH Operation

During heat-up, the bellows element is contracted and fully open to discharge all non-condensable gas and condensate. As recorded temperature rises, not as much condensate is formed, and the temperature of the condensate rises as the level in the upstream tubing falls. This causes the bellows element to expand, closing the valve. As condensate accumulates in the body, the element cools, causing the bellows/stem tip to retract allowing condensate to drain.

Features

- Compact size makes it the ideal sanitary trap for tight fitting process skid applications
- Competitive lay-in dimensions allow in kind replacement of troublesome existing installations
- Low subcooling operation reduces probability of temperature validation faults and resultant SIP delays
- Higher capacities and lower subcooling than competitive designs allows faster heat-up

New: Compact Series - ideal for small scale skids!



- All 316L stainless steel housing and internals
- Polished components – body interior is mechanically polished to 20Ra finish, exterior to 40 Ra
- Self draining when installed vertically (outlet side down)
- Option for electropolished body

Applications

- Typical applications are: temperature validated sterilization drainage of fermenters, bioreactors, separation and filtration equipment, lyophilizers, autoclaves, process piping equipment and steam barriers.
- Condensate drainage from clean steam distribution lines

SPECIFICATIONS

Sizes: 1/4" (DN8), 3/8" (DN10), 1/2" (DN15), 3/4" (DN20), 1" (DN25)

End Connections

- Standard – NPT
- Optional – BSP, EN ISO 228-1

Material

- Body Inlet/Outlet: 316L Stainless Steel (ASME SA-479 or ASME SA-351 Gr. CF8M)
- Body outlet: 316L Stainless Steel
- Thermal Element: 316L Stainless Steel
- O-Ring (Standard): Teflon / Viton, FDA US Class VI

Maximum Operating Conditions

- Maximum Operating Pressure (PMO): 90 psig (6,2 bar)
- Maximum Allowable Temperature (TMA): 350°F (177°C)

Design Pressure/Temperature Rating:

- Maximum Allowable Pressure (PMA): 145 psig (10,0 bar)
- Maximum Allowable Temperature (TMA): 350°F (177°C)

Maximum Recommended Differential Pressure:

- MK93TH with Standard Bellows: 10 - 50 psig (0,7 -3,4 bar)
- MK93TH with High Pressure Bellows: 50 - 90 psig (3,4 -6,2 bar)

Cold water Cv: 1.63

Flow Capacity

Steam Pressure psig (bar)	Lbs/Hr (Kg/hr) @ 5° subcooling	Lbs/Hr (Kg/hr) @ 10° subcooling	Lbs/Hr (Kg/hr) @ 20° subcooling
10 (0,7)	195 (88)	490 (222)	1127 (511)
20 (1,3)	373 (169)	813 (369)	1697 (770)
30 (2,0)	549 (249)	1142 (518)	2202 (999)
50 (3,4)	870 (394)	1715 (778)	3074 (1394)
75 (5,2)	1012 (459)	2207 (1001)	3932 (1783)
90 (6,2)	1165 (528)	2437 (1105)	4139 (1877)

Cold Water Capacity

Steam Pressure psig (bar)	Cold Water Lbs/Hr (Kg/Hr)
10 (0,7)	2580 (1170)
20 (1,3)	3648 (1655)
30 (2,0)	4468 (2027)
50 (3,4)	5768 (2616)
75 (5,2)	6944 (3150)
90 (6,2)	7504 (3404)

MK93TH SANITARY STEAM TRAPS

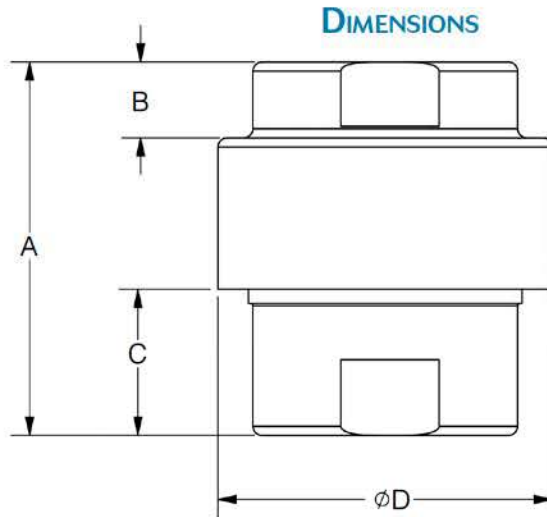

Valve Size	Dimensions (inches)			
	A	B	C	ØD
1/4"	2.0	0.38	0.84	2.21
3/8"	2.6	0.47	1.08	2.21
1/2"	2.4	0.50	0.87	2.21
3/4"	2.6	0.57	0.99	2.21
1"	2.9	0.72	1.11	2.21

Valve Size	Dimensions (mm)			
	A	B	C	ØD
DN8	50,5	9,6	21,3	56,1
DN10	68,0	11,9	27,4	56,1
DN15	61,0	12,7	22,1	56,1
DN20	68,0	14,1	25,1	56,1
DN25	75m0	18,2	28,1	56,1

FEATURES & BENEFITS

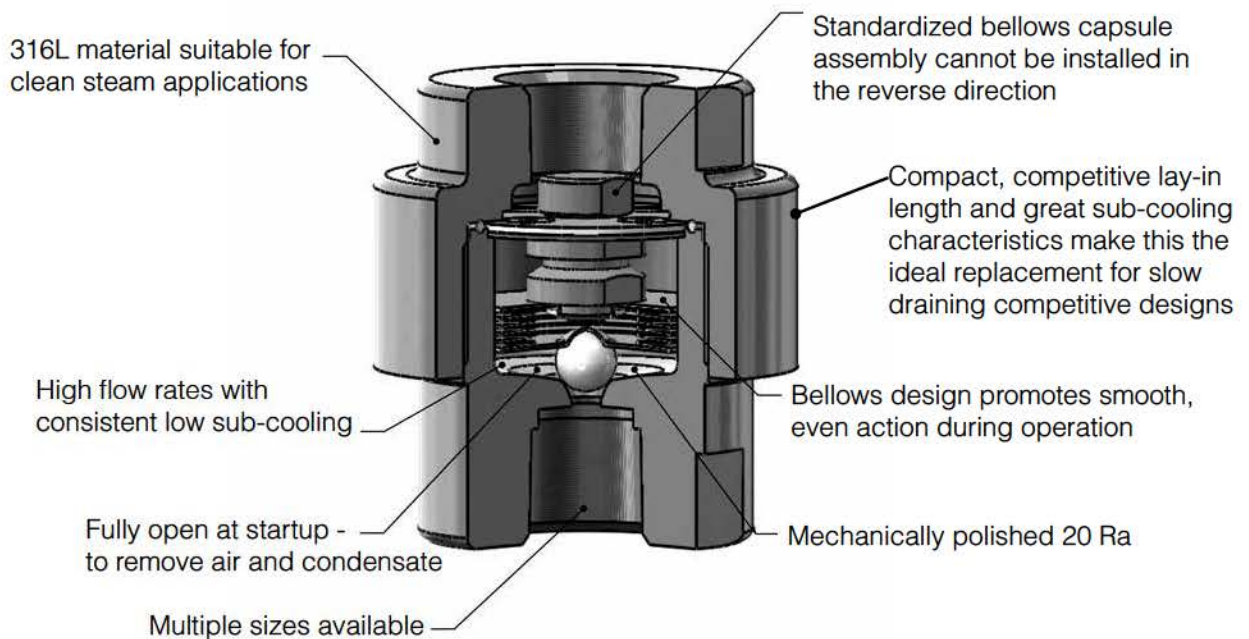

ORDERING SCHEMATIC

Model	Body	–	Size	–	End Connections	–	Special Options
93	TH	–	050	–	N	–	P

1	Model/Body Joint
93TH	Threaded Body, Standard

4	Options
	None (Standard Bellows)
P	High Pressure Bellows
L	Electropolish

2	Size	
025	1/4"	DN8
038	3/8"	DN10
050	1/2"	DN15
075	3/4"	DN20
100	1"	DN25

Note: if blank, standard bellows will apply
 Note: you can combine up to 2 options in alphabetical order.

For example: 93TH-075-N-PL
 = MK93TH with a 3/4" NPT Threaded Inlet/Outlet, High Pressure Bellows, Electropolished body

Note: if option 'P' under special options is not selected, the standard bellows will be supplied.

For example: 93TH-050-N-L
 = MK93TH with 1/2" NPT Threaded Inlet/Outlet, Standard Bellows, Electropolished body

3	End Connections
	Inlet/Outlet
N	NPT Threaded Inlet/Outlet
B*	BSPT Threaded Inlet/Outlet
E*	EN ISO 228-1 Threaded Inlet/Outlet

* BSP and EN ISO 228-1 threads available upon request - consult factory

Steriflow Valve reserves the right to make revisions to its products, specifications, literature, and related information without notice. Please visit our website at www.steriflowvalve.com for the latest information on our products.