

Mark 94 Series

High Flow Sanitary Steam Traps

The Mark 94 is a thermostatic steam trap designed specifically for use in high capacity clean steam systems where sanitary conditions must be maintained. It features a 20 Ra finish on all internal wetted parts, and a self-draining design, to minimize the possibility of medium entrapment and bacterial growth.

The Mark 94 has been designed to provide high condensate flow rates during SIP heat up, allowing vessels and other process equipment to reach validation temperature in minimum time.

The proprietary fill, bellows and orifice design minimize the subcooling required to open the trap during SIP temperature hold, insuring fast drainage under lower load conditions to help insure against low temperature faults.

The Mark 94 is designed for use up to 50 psig (3,5 bar) inlet pressure.

OPERATION

During SIP Heatup, the bellows assembly is fully open to discharge all air, non-condensate gases and cool condensate. The heat of the entering steam causes the element to expand, closing the valve. As condensate accumulates in the body, the element cools, causing the bellows/stem tip to retract allowing condensate to flow.

FEATURES

- Body and solid internal components constructed of ASTM A479 316L
- Polished components – body interior and exterior are mechanically polished to 20 Ra and 40Ra finish respectively
- Sanitary clamp ends standard, other ends (tube weld, threaded, ISO/DIN) available upon request
- Self draining when installed vertically (outlet side down)
- New design provides excellent flow rates with low subcooling during heat up and temperature hold period
- FDA, USP Class VI gasket standard
- Horizontal connections available



APPLICATIONS

- Typical applications are: fermentors, bioreactors, sterilizers/autoclaves
- Condensate drainage from large tube clean steam distribution loops
- Condensate drainage from large scale process systems – fermenters, bioreactors, holding vessels, separators, chromatography vessels, etc.

SPECIFICATIONS

Sizes: 3/4" (DN20), 1" (DN25), 1-1/2" (DN40)

End Connections

- Standard – Sanitary clamp ends (Tri-Clamp)
- Optional – Tube weld ends, DIN/ISO, threaded

Connection Orientation: Vertical or horizontal

Material

- Body Inlet/Outlet: ASTM A479 316L Stainless Steel
- Thermal Element: 316L Stainless Steel
- O-Ring-Gasket: Viton, Teflon Encapsulated (FDA, USP Class VI approved)
- Clamp: 304 SST

Nominal Cv: 4.0

Maximum Operating Conditions

- Maximum Operating Pressure (PMO): 50 psig (3,5 bar)
- Maximum Allowable Temperature (TMA): 350°F (177°C)

Design Pressure/Temperature Rating

- Maximum Allowable Pressure (PMA): 145 psig (10,0 bar)
- Maximum Allowable Temperature (TMA): 350°F (177°C)

Maximum Recommended Differential Pressure

- MK94: 5 – 50 psi (0,34 – 3,5 bar)

CRN Number: CRN13987.5

Weight: 2.5 lbs (1,2 kgs)

FLOW CAPACITY TABLE

3/4" (DN20) Size Inlet/Outlets

Condensate Temp Below Saturation (Subcooled Temp)	Capacity - lbs/hr (kg/hr) @ Differential Pressure - psi (bar)				
	10 (0,69)	20 (1,38)	30 (2,07)	40 (2,76)	50 (3,45)
5°F	1355 (616)	1800 (818)	2460 (1118)	3050 (1386)	3410 (1550)
10°F	2190 (996)	3065 (1393)	3920 (1782)	4620 (2100)	5160 (2346)
20°F	3720 (1691)	5010 (2277)	5985 (2721)	7190 (3268)	7845 (3566)
Cold Water	5870 (2668)	8280 (3764)	10140 (4609)	11710 (5323)	13100 (5955)

1" & 1-1/2" (DN25 & DN40) Size Inlet/Outlets

Condensate Temp Below Saturation (Subcooled Temp)	Capacity - lbs/hr (kg/hr) @ Differential Pressure - psi (bar)				
	10 (0,69)	20 (1,38)	30 (2,07)	40 (2,76)	50 (3,45)
5°F	1490 (677)	1980 (900)	2705 (1230)	3355 (1525)	3750 (1705)
10°F	2410 (1096)	3370 (1532)	4310 (1959)	5080 (2309)	5675 (2580)
20°F	4090 (1859)	5510 (2505)	6585 (2993)	7910 (3596)	8630 (3923)
Cold Water	6460 (2936)	9110 (4141)	11550 (5250)	12800 (5818)	14410 (6550)

DIMENSIONS - VERTICAL CONNECTIONS

Bolted Clamp

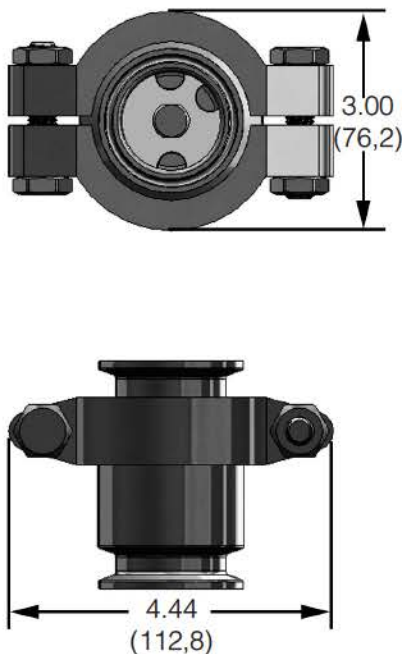

Traditional Wingnut Clamp

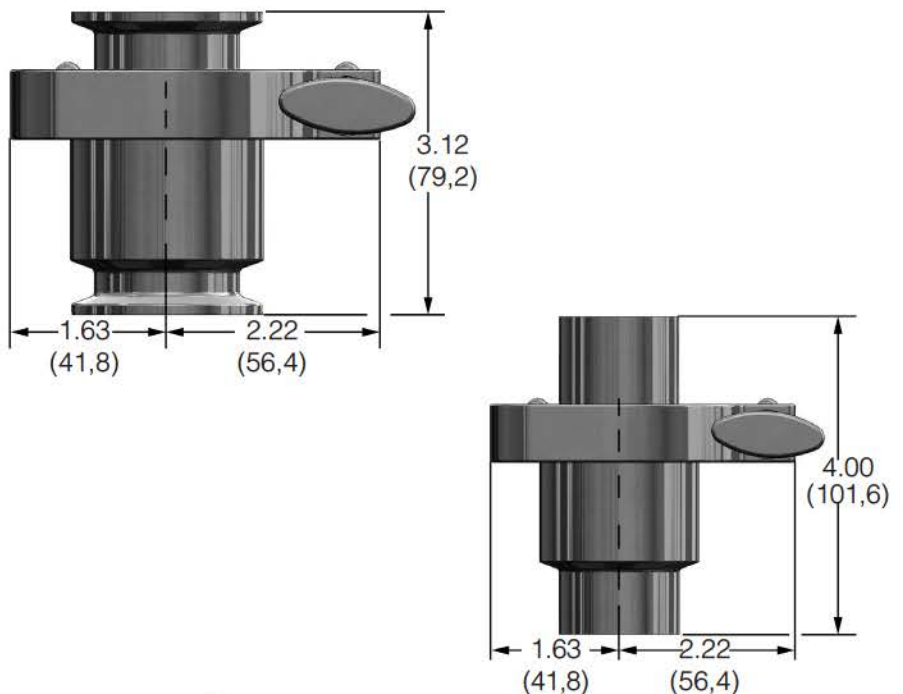

DIMENSIONS - HORIZONTAL CONNECTIONS

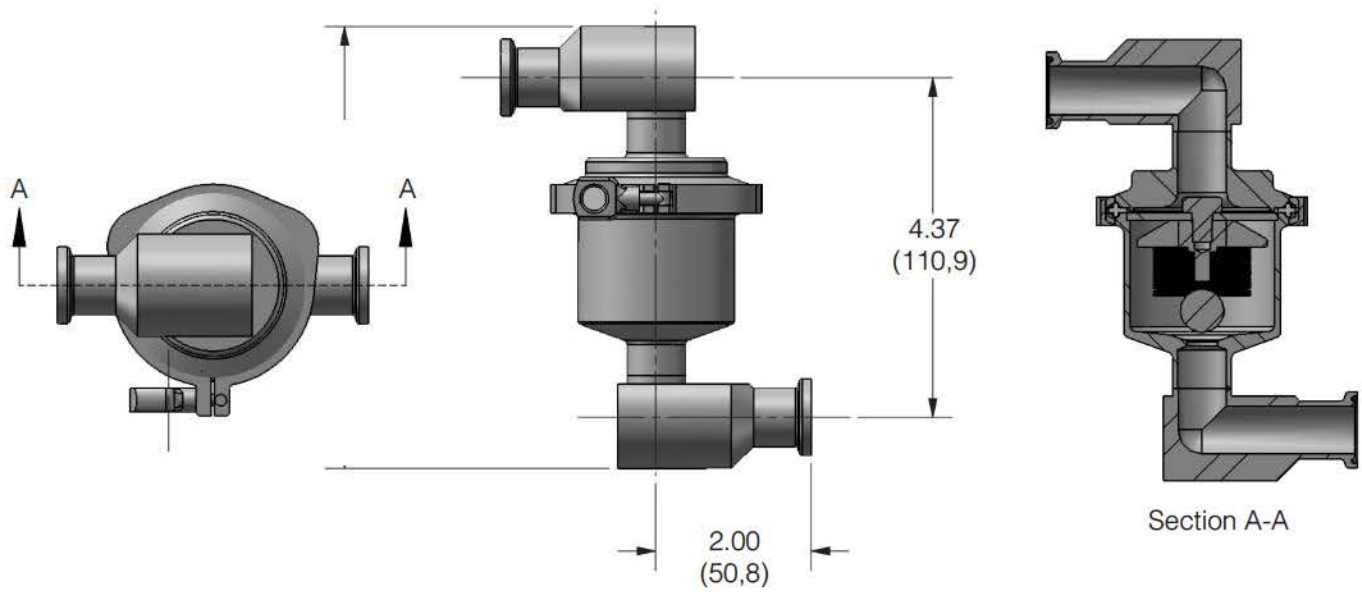

FEATURES & BENEFITS

Proprietary fill and bellows construction insures low subcooling operation. Fast reaction to temp change insures minimum condensate backup upstream of trap.

Choice of traditional or bolted Tri-clamp standard

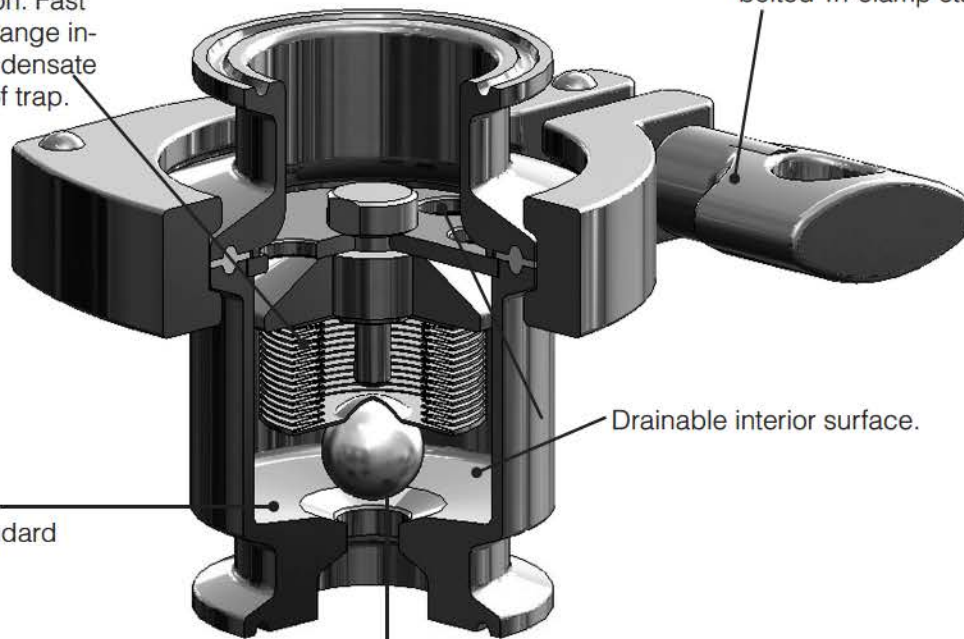

Ball type tip helps insure low subcooling operation by providing maximum flow with minimum lift. Helps insure minimum condensate backup upstream of trap.

SPECIFICATION

Fully drainable, high capacity sanitary steam trap with body and plug components made from ASTM A479 316L. Ball type stem tip pulls completely out of orifice flow path allowing full flow between 1355 #/hr of 50F subcooled condensate at SIP vessel maintenance temperature, to 14410 #/hr max cool water flow during SIP heat up.

ORDERING SCHEMATIC

Model	Body	—	Size	—	End Connections	—	Special Options
94	C	—	075	—	C	—	K

Model/Body Joint	
94C	Tri-Clamp Standard

Size		
075	3/4"	DN20
100	1"	DN25
150	1-1/2"	DN40

4	Options
G	Tuf-Steel, TFE/SST Body Gasket, FDA USP Class VI
K	Bolted Clamp
L	Electropolish
S	Silverback Gasket TFE/SST Body Gasket, USP Class VI
Z	Non-Standard

Note: You can combine up to two options in alphabetical order.

For example: 94C-075-CHCH-LS

= MK94C with 3/4" Tri-clamp body, wingnut clamp, horizontal inlet and outlet with electropolish body and silverback gasket

Note: Note: if no gasket is specifically requested, a TFE/Viton gasket is provided

3 End Connections				
Inlet		Outlet		
C				Inch Tri-Clamp Vertical Inlet/Outlet
S				ISO Tri-Clamp Vertical Inlet/Outlet
D				DIN Tri-Clamp Vertical Inlet/Outlet
T				Inch Tube Vertical Inlet/Outlet
M**				DIN Tube Vertical Inlet/Outlet
P***				ISO TUBE Vertical Inlet/Outlet
Z				Non-Standard
C	H	C	H	Inch Tri-Clamp Horizontal Inlet/Outlet
C	H	C	V	Inch Tri-Clamp Horizontal Inlet/Vertical Outlet
C	V	C	H	Inch Tri-Clamp Vertical Inlet/Horizontal Outlet

** According to DIN 1186, DIN 11850 row A

*** According to ISO DIN 1186 line B, ISO 1127



Steriflow, a division of Jordan Valve
 3170 Wasson Road • Cincinnati, OH 45209
 513.533.5600 • 800.543.7311 • 513.871.0105 (f)
 steriflow@richardsind.com • www.steriflowvalve.com

Steriflow Valve reserves the right to make revisions to its product, specifications, literature and related information without notice. Please visit our website at www.steriflowvalve.com for the latest information on our products.