

Mark 96C Series

CRN Registration Number Available

Sanitary Pressure Regulators (1/2"–1")

The Mark 96C is a clamped body pressure reducing valve designed to regulate downstream pressure of process and utility applications in sanitary and aseptic systems.

The Mark 96C operates by sensing pressure under the diaphragm after the medium has entered the valve from the bottom inlet port. As the downstream pressure approaches the set point, the force caused by the pressure acting on the diaphragm overcomes the force of the range spring, and the plug begins to move up toward closed. This reduces the downstream pressure and maintains the set point as the flow exits the valve from the side port. If the pressure underneath the diaphragm begins to fall, the spring forces the plug to move down towards open, to allow the set point to be maintained.

FEATURES

- CRN Registration Number Available
- Soft seat capability for ANSI Class VI shutoff
- No guiding surfaces in the fluid – prevents particulate generation
- 100% 316L barstock body and metal trim
- Self-draining design
- No threads in contact with service media – prevents accumulation of contaminants
- Easy to disassemble for cleaning
- Clean-in-Place, Steam-in-Place – dome lock pin to allow CIP/SIP
- Jorton diaphragm: A USP Class VI, FDA approved PTFE based material which provides excellent chemical resistance, extremely long life in steam service. Far superior to other elastomer or metal diaphragm metals.

DOCUMENTATION

The following documentation is available, free of charge, from our factory upon request at time of ordering:

- Traceable Material Certificates (free of charge for body and ferrules)
- FDA or USP Class VI certificates on most soft seal materials
- Final Test Reports
- Certificate of Surface Finish
- Certificate of Compliance/Certificate of Origin



AVAILABLE FINISHES

Body

- *Standard:* 20 Ra μ in (.5 Ra μ m) mechanical finish and electropolish on inside wetted surfaces; machine finish and electropolish on exterior

Stem

- *Standard:* 20 Ra μ in (.5 Ra μ m) mechanical finish and electropolish
- *Optional:* 8 Ra μ in (.2 Ra μ m) finish

Spring Housing

- *Standard:* as cast, and electropolished

Adjusting Screw

- *Standard:* machine finish and electropolish

APPLICATIONS

A wide variety of applications exist for the MK96C in the pharmaceutical, biotech, health-care, food & beverage and other industries. The Mark 96C is suitable for liquid, gas and steam service

SPECIFICATIONS

Sizes: 1/2" (DN15), 3/4" (DN20), 1" (DN25),

End Connections

- ASME BPE Tri-Clamp connections
- DIN/ISO sanitary connections available upon request

Body/Spring housing Clamp: 3 segment Tri-clamp, Bolted Clamp available as option

Body & Trim Materials: 316L Stainless Steel (ASTM A479)

Spring Housing Materials: CF8M Cast SST

Seat Materials

- Standard hard seat – integral 316L SST seat
- Optional soft seat
 - Jorlon (for 1" size Cv 2.5 and above) (FDA & USP Class VI) for steam and hot fluid service to 338°F (170°C)
 - PEEK (FDA & USP Class VI) for steam and hot fluid service to 350° (177°C)
 - Teflon (for Cv 1.5, 1" size and above) to 252°F (122°C) continuous or 275°F (135°C) intermittent [not to exceed 15 min. in a one hour period] FDA, USP Class VI

Note: consult factory for 1/2" & 3/4" soft seat materials

Diaphragm Materials

- Jorlon (recommended) – to 400°F (204°C) FDA, USP Class VI
- EPDM/Nylon – to 275°F (135°C), FDA only

O-Ring Materials

- EPDM (to 275°F, 135°C) – FDA, USP Class VI
- Buna-N (to 225°F, 107°C) – FDA
- Viton (to 400°F, 204°C) – FDA, USP Class VI
- Silicone (to 400°F, 204°C) – FDA, USP Class VI
- Teflon-Encapsulated Viton (to 400°F, 204°C) – FDA, USP Class VI*

* For Cv's < 1.2, Teflon encapsulated o-rings not available

- Kalrez® (to 450°F, 232°C) – FDA, USP Class VI

Shutoff: ANSI Class III hard seat or Class VI soft seat

Body Pressure Temperature Rating: (dependent upon construction)

Valve Size	PSIG @ 100°F	PSIG @ 225°F
1/2", 3/4", 1"	250 (17,2 bar)	200 (13,8 bar)*
Valve Size	PSIG @ 100°F	PSIG @ 275°F
1/2", 3/4", 1"	250 (17,2 bar)	140 (9,6 bar)**

* Optional 2 segment clamp

** Standard 3 segment clamp

Setpoint Spring Ranges

Valve Size	Setpoint Ranges, PSI (BAR)
1/2", 3/4", 1"	3-8* (0,1-0,5*), 5-25 (0,4-1,7), 15-50 (1,0-3,4), 40-90 (2,7-6,2) or 75-135 (5,2-9,3)

* Range available with EPDM/Nylon diaphragm only. Maximum pressure drop 40 psi.

Cv (Kv) Ratings:

Valve Size	Available Cvs (Kvs)	Cv for Relief Valve Sizing
1/2"	0.3*†, 0.5*†, 1.2* (0,3*†, 0,4*†, 1,0*)	3.8
3/4"	0.5*†, 1.5 (0,4*†, 1,3)	3.8
1"	0.5*†, 1.5, 2.5 or 5.5 (0,4*†; 1,3; 2,2; 3,9 or 4,7)	10.7

* For Cv's ≤1.2, Teflon encapsulated o-rings not available

† Maximum inlet pressure 40 psi over set point for Cv's 0.3 and 0.5 Consult factory for additional size/Cv combinations

*** When using the 3-8 range spring with EPDM/Nylon diaphragm, the following sizing limits apply:

Set Point	Sizing Limit (of rated capacity)
8	50%
5	33%
3	25%

For example a 1" Cv5.5 valve with a 3-8 range spring, if the customer's set point is P2 = 8 psi, then the actual Cv sizing should not exceed 2.75Cv. If the customer's intended set point is P2 = 5 psi, then the actual Cv sizing should not exceed 1.8Cv and if their set point is P2 = 3 psi, then the actual Cv sizing should not exceed 1.38 Cv.

DIMENSIONS

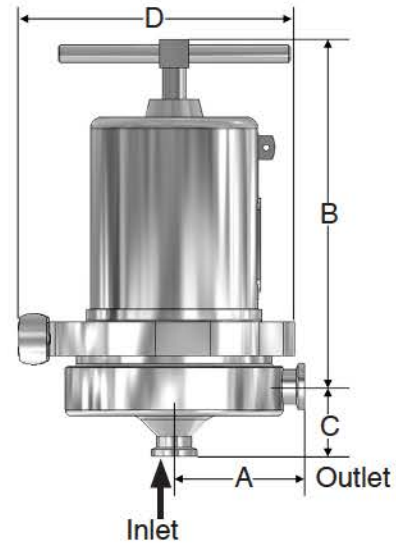

Valve Size	Dimensions (inches)				Weight Lbs
	A	B	C	D	
1/2"	3.29	8.30	1.08	5.2	18
3/4"	3.29	8.30	1.50	5.20	18
1"	3.50	8.44	1.64	5.20	20

Valve Size	Dimensions (mm)				Weight Kgs
	A	B	C	D	
DN15	84	211	27,4	132	8,1
DN20	84	211	38,1	132	8,1
DN25	89	214	41,7	132	9,1

Based on US tri-clamp ends. Consult factory for DIN and ISO tri-clamp

FEATURES & BENEFITS

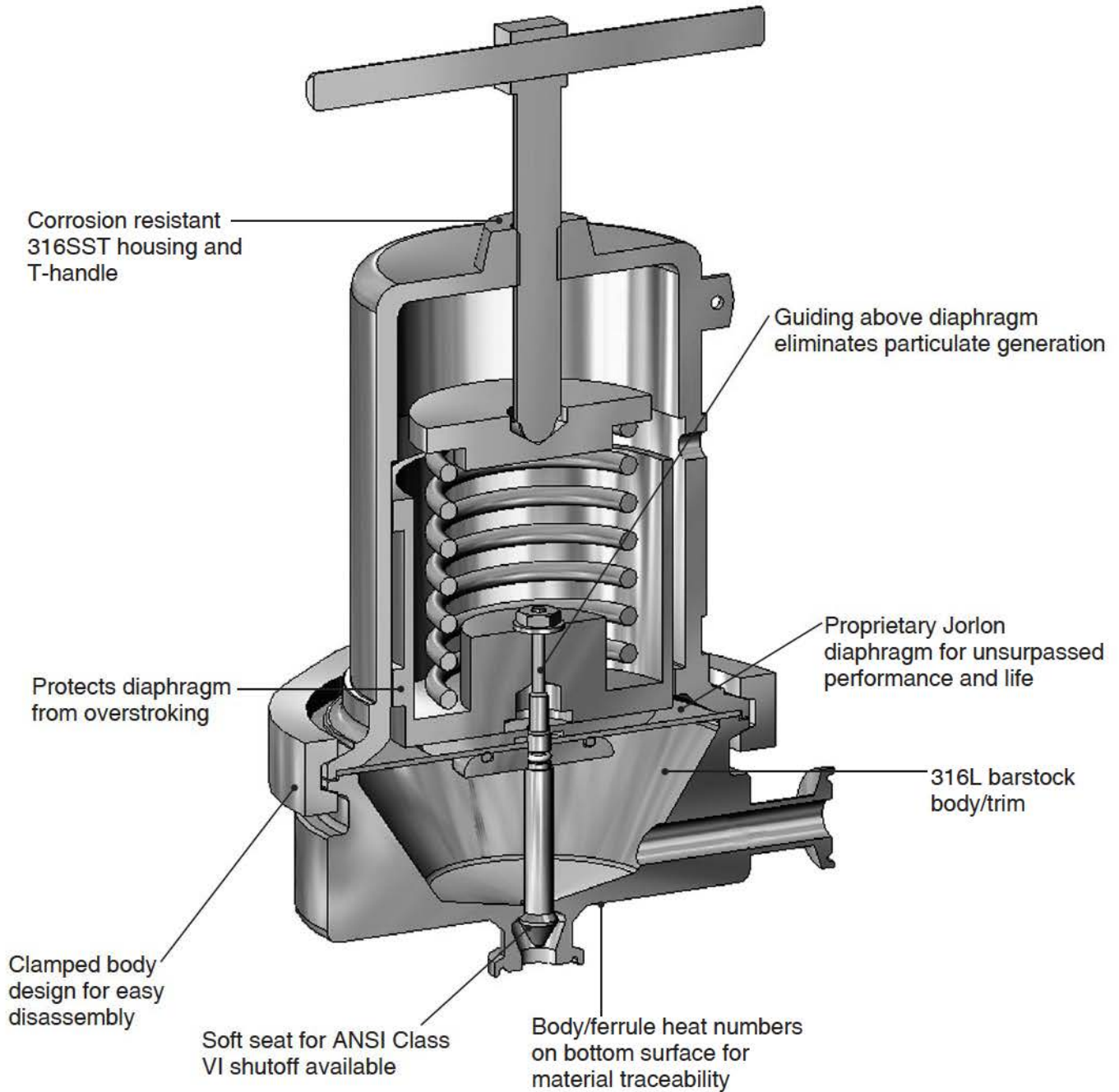

FEATURES & BENEFITS

Stainless Steel sanitary pressure regulator shall be made from ASTM A479 barstock material, mechanically finished to 20 Ra μ in (.5 Ra μ m), electropolished which includes body and all wetted metal parts. Regulator shall be activated by FDA approved, USP Class VI certified Jorlon diaphragm. Guiding of valve stem/plug shall be outside of the wetted, process areas of valve internal, above diaphragm. Regulator shall be free of threads within wetted, process areas of valve internal and shall be self-draining when installed with inlet vertical and below valve assembly.

ORDERING SCHEMATIC

1	—	2	—	3	/	4	5	6	7	8	9	10	11	12
---	---	---	---	---	---	---	---	---	---	---	---	----	----	----

1	Model
96C	Standard

2	Size
050	1/2" (DN15)
075	3/4" (DN20)
100	1" (DN25)

3	Body Material
6L	316L

4	Body Finish
A	20Ra EP (SF5) Interior/63RMS Exterior (Std)
C	8Ra Interior/63RMS Exterior

5	Body Cv (Kv)	
	Cv	Kv
B	All 1/2"	All 1/2"
A	0.5 (3/4" & 1")	0.43 (3/4" & 1")
C	1.5 (3/4" & 1")	1.3 (3/4" & 1")
F	2.5 (1")	2.15 (1")
L	5.5 (1")	4.7 (1")

6	Trim Finish
A	20Ra (Standard)
B	8Ra

7	Trim – Cv (Kv) & Seat			
3	0.3 (0.24) Hard Seat	B	2.5 (2.15) Hard Seat	
4	0.3 (0.24) PEEK Seat	C	2.5 (2.2) Teflon Seat	
5	0.5 (0.43) Hard Seat	D	2.5 (2.15) Jorlon Seat	
6	0.5 (0.43) PEEK Seat	L	5.5 (4.7) Hard Seat	
Y	1.2 (1.03) Hard Seat	M	5.5 (4.7) Teflon Seat	
1	1.2 (1.03) PEEK Seat	N	5.5 (4.7) Jorlon Seat	
A	1.5 (1.3) Hard Seat			

8	O-Ring/Diaphragm
EE	EPDM/EPDM Diaphragm 1.5-5.5Cv
JE	O-Ring EPDM/Jorlon Diaphragm 1.5-5.5Cv
JK	O-Ring Kalrez/Jorlon Diaphragm 1.5-5.5Cv
JS	O-Ring Silicon/Jorlon Diaphragm 1.5-5.5Cv
JV	O-Ring Viton/Jorlon Diaphragm 1.5-5.5Cv
TY	Teflon Encaps. Viton/Jorlon Diaphragm 1.5-5.5Cv
B5	Buna-N/Jorlon 0.3-1.2Cv
E5	EPDM/EPDM Diaphragm 0.3-1.2Cv
J5	O-Ring EPDM/Jorlon Diaphragm 0.3-1.2Cv
K5	O-Ring USP-Kalrez/Jorlon Diaphragm 0.3-1.2Cv
S5	Silicon/Jorlon Diaphragm 0.3-1.2Cv
V5	Viton/Jorlon Diaphragm 0.3-1.2Cv

9	Adjusting Screw Finish (Except Threads)
A	Electro-polished (Standard)

10	Range PSI (Bar) see chart on page 2
A	3 - 8 (0.2 - 0.6)*
C	5 - 25 (0.3 - 1.7)
H	15-50 (1.0-3.4)
R	40-90 (2.8-6.2)
T	75-135 (5.2-9.3)

* Must use EPDM/Nylon diaphragm

11	Diaphragm
EP	EPDM 1.5-5.5 Cv
JL	Jorlon 1.5-5.5 Cv
E5	EPDM 0.3-1.2 Cv
J5	Jorlon 0.3-1.2 Cv

12	Actuator Finish
AA	Standard

13	PED Compliance
00	Not Required
0G	SEP Compliant
ZZ	Non-Standard

Note: Steriflow does not recommend using metal seated trim on any service where the flow will be deadheaded downstream of the pressure reducing regulator. Use an appropriate Teflon, Jorlon or Peek soft seat for the trim instead.



Steriflow, a division of Jordan Valve
 3170 Wasson Road • Cincinnati, OH 45209
 513.533.5600 • 800.543.7311 • 513.871.0105 (f)
 steriflow@richardsind.com • www.steriflowvalve.com

Steriflow Valve reserves the right to make revisions to its product, specifications, literature and related information without notice. Please visit our website at www.steriflowvalve.com for the latest information on our products.