



PowerDyne® STEAM TRAP

MODEL P46SRN/P46SRM/P46SRW/P65SRN

THERMODYNAMIC DISC TRAP WITH THERMOSTATIC AIR VENTING

Benefits

Inline repairable trap for steam mains, tracers and coils, with wide capacity range to match various conditions. Available in carbon steel or stainless steel.

1. Inline replaceable valve module to lower repair costs.
2. Air-jacketing reduces no-load cycling and extends service life.
3. Quick thermostatic air venting with bimetal ring for fast start-up.
4. Lapped disc provides steam-tight seal without air binding for long service life.
5. Built-in screen for extended trouble-free service.
6. Hardened stainless steel working surfaces for long service life.



Specifications

Model	P46SRN				P46SRM				P46SRW	P65SRN			
	A105		A182 F304		A105		A182 F304		A216 Gr.WCB	A105		A182 F304	
Body Material	S		SW		S		SW		S, SW	S		SW	
Connection	S		SW		S		SW		S, SW	S		SW	
Size (in)	3/8, 1/2, 3/4, 1	1/2, 3/4, 1	3/8, 1/2, 3/4, 1	1/2, 3/4, 1	1/2, 3/4, 1	1/2, 3/4, 1	1/2, 3/4, 1	1/2, 3/4, 1	1	1/2, 3/4, 1	1/2, 3/4, 1	1/2, 3/4, 1	1/2, 3/4, 1
Max. Oper. Press. (psig) PMO	650				650				650	925			
Min. Oper. Press. (psig)	5												
Max. Oper. Temp. (°F) TMO	800												
Max. Allow. Press. (psig) PMA*	1192 @ 100°F		1294 @ 100°F		1192 @ 100°F		1294 @ 100°F		1097@100°F	1550 @ 100°F		1683 @ 100°F	
Max. Allow. Temp. (°F) TMA*	800 @ 710psig		1022 @ 664psig		800 @ 710psig		1022 @ 664psig		800@667psig	800 @ 943psig		1022 @ 863psig	
Maximum Back Pressure	80% of inlet pressure												

* Refer to Pressure Temperature Rating section on reverse for details. Standard TLV coating is applied to stainless steel models as well.

Connections and sizes in bold are standard
S=Screwed, SW=Socket Weld, F=Flanged

No.	Description	Material	ASTM/AISI ¹⁾	JIS	
①	Body	See Specifications table for available materials			
② ^R	Module	P46SRN/M/W	Stainless Steel	AISI420F	SUS420F
	Valve Seat	P65SRN	Stainless Steel	AISI440C	SUS440C
③ ^R	Cover		Stainless Steel	AISI420F2	SUS420F2
④ ^R	Disc	P46SRN/M/W	Stainless Steel	AISI420	SUS420J2
		P65SRN	Stainless Steel	AISI440C	SUS440C
⑤ ^R	Disc Holder	P46SRN/M/W	Stainless Steel	AISI420	SUS420J2
	Ring	P65SRN	Stainless Steel	AISI630	SUS630
⑥ ^R	Air Vent Ring		Bimetal	—	—
⑦ ^{MR}	Outer Module Gasket		Graphite/Stainless Steel	-/AISI316L	-/SUS316L
⑧ ^R	Nameplate		Stainless Steel	AISI304	SUS304
⑨ ^{MR}	Inner Module Gasket		Graphite/Stainless Steel	-/AISI316L	-/SUS316L
⑩ ^R	Screen		Stainless Steel	AISI430	SUS430
⑪ ^{MR}	Screen Holder Gasket		Soft Iron	AISI1010	SUYP
			Stainless Steel ²⁾	AISI316L	SUS316L
⑫	Screen Holder		Cast Stainless Steel	A351 Gr.CF8	—
⑬	Cap		Stainless Steel	AISI304	SUS304
⑭	Socket ³⁾		Carbon Steel	A105	—
	P65SRN 1" SW		Stainless Steel ²⁾	AISI304	SUS304
⑮	Flange ³⁾		Carbon Steel	A105	—
⑯	BD2 Blowdown Valve ⁴⁾		Cast Stainless Steel	A351 Gr.CF8	—

¹⁾ Equivalent ²⁾ For models with stainless steel body ³⁾ Shown on reverse ⁴⁾ Option
Replacement kits available: (M) maintenance parts, (R) repair parts



To avoid abnormal operation, accidents or serious injury, DO NOT use this product outside of the specification range. Local regulations may restrict the use of this product to below the conditions quoted.

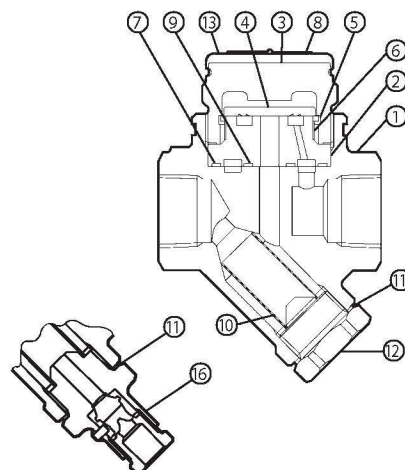

Dimensions

● **P46SRN/P46SRM/P46SRW/P65SRN**
Screwed

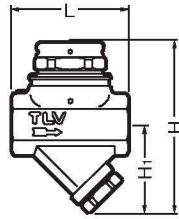

● **P46SRN/P46SRM/P46SRW/P65SRN**
Socket Weld

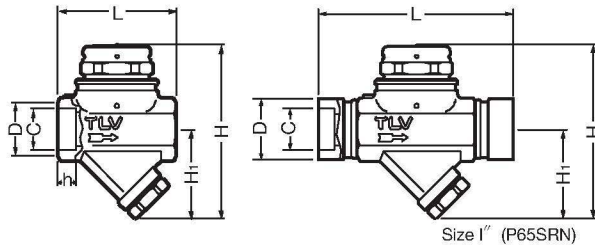

● **P46SRM**
Flanged

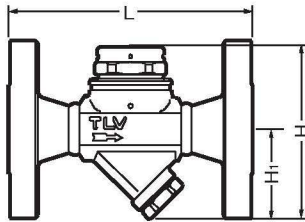

P46SRN/P46SRM/P46SRW/P65SRN Screwed* (in)

Model	Size	L	H***	H ₁ ***	Weight (lb)
P46SRN	3/8**	3 1/8	4 3/4	2 7/16	2.6
P46SRM	1/2				
P65SRN	3/4				
P46SRW	1	3 7/16	4 15/16	2 7/16	3.1
	1	3 7/16	5 1/16		3.5

* NPT, other standards available ** Only available for P46SRN
*** With optional BD2, add approx. 3/16" to H and H₁

P46SRN/P46SRM/P46SRW/P65SRN Socket Weld* (in)

Model	Size	L	H**	H ₁ **	φD	φC	h	Weight (lb)
P46SRN	1/2	3 1/8	4 3/4	2 7/16	1 3/16	0.855	1/2	2.6
P46SRM	3/4				1 7/16	1.065		
P46SRW	1	3 7/16	4 15/16	2 7/16	1 3/4	1.330	1/2	3.1
	1	3 7/16	5 1/16	2 7/16	1 3/4	1.330		3.5
P46SRN	1/2	3 1/8	4 3/4	2 7/16	1 3/16	0.855	1/2	2.6
	3/4				1 3/4	1.065		3.1
	1	5 7/8	4 3/4	2 7/16	2	1.330	3/16	3.7

* ASME B16.11-2005, other standards available
** With optional BD2, add approx. 3/16" to H and H₁

P46SRM Flanged (in)

Model	Size	L			H*	H ₁ *	Weight** (lb)
		Connects to ASME Class	150RF	300RF			
P46SRM	1/2	5 1/2			4 3/4	2 7/16	7.3
	3/4	6 1/2					10
	1	8 1/4					13

Other standards available, but length and weight may vary
* With optional BD2, add approx. 3/16" to H and H₁
** Weight is for Class 600 RF

Discharge Capacity

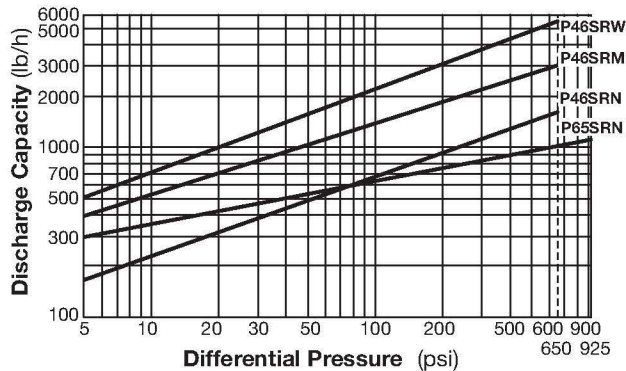

- Differential pressure is the difference between the inlet and outlet pressure of the trap.
- Recommended safety factor: at least 2.

Pressure Temperature Rating*

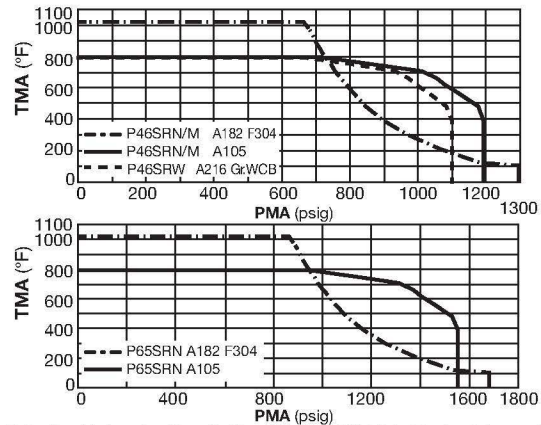

*This Rating Graph is based on Allowable Stress Values of ASTM-Materials at each temperature.



DO NOT DISASSEMBLE OR REMOVE THIS PRODUCT WHILE IT IS UNDER PRESSURE.
Allow internal pressure of this product to equal atmospheric pressure and its surface to cool to room temperature before disassembling or removing. Failure to do so could cause burns or other injury. READ INSTRUCTION MANUAL CAREFULLY.

TLV CORPORATION

13901 South Lakes Drive, Charlotte, NC 28273-6790
Phone: 704-597-9070 Fax: 704-583-1610
E-mail: tlv@tlvengineering.com
For Technical Service 1-800 "TLV TRAP"



Manufacturer

ISO 9001/ISO 14001



Kakogawa, Japan

is approved by LROA Ltd. to ISO 9001/14001

