

TLV

PowerTrap®

MODEL GP10M

SECONDARY PRESSURE DRAINER FOR PUMPING APPLICATIONS

Benefits

Pump for a wide range of applications. Ideal for low flow condensate removal from vented receivers situated at low level.

1. No cavitation or seal leakage.
2. Non-electric design with durable nickel-based alloy compression spring for reliable performance.
3. Pump will operate with a low filling head (min. 12").
4. Easy, inline access to internal parts simplifies cleaning and reduces maintenance costs.
5. Intake/exhaust valve heads are both Rockwell 65C with 45C seats for maximum durability.
6. High quality stainless steel internals ensure reliability.
7. Compact design permits installation in a limited space.
8. Float resists hydraulic shock to 1500 psig.
9. 2-year warranty for snap-action mechanism.*
10. Cycle Counter installable as option.

* Contact TLV for details



Specifications

Model		GP10M
Connection	Pumped Medium Inlet & Outlet	Flanged*
	Motive Medium & Pump Exhaust	Screwed
Size (in)	Pumped Medium: Inlet x Outlet	1½ x 1
	Motive Medium Inlet	½
	Pump Exhaust Outlet	½
Maximum Operating Pressure (psig)	PMO	150
Maximum Operating Temperature (°F)	TMO	365
Maximum Allowable Pressure (psig)	PMA	Cast Iron: 230 Cast Steel: 300
Maximum Allowable Temperature (°F)	TMA	428
Motive Medium Pressure Range (psig)		5 – 150
Maximum Allowable Back Pressure		7 psi less than motive medium pressure used
Volume of Each Discharge Cycle (gal)		approximately 2
Motive Medium**		Saturated Steam, Compressed Air, Nitrogen
Pumped Medium***		Steam Condensate, Water

* For details of flange connection, see picture at bottom right

** Do not use with toxic, flammable or otherwise hazardous fluids.

*** Do not use for fluids with specific gravities under 0.85 or over 1, or for toxic, flammable or otherwise hazardous fluids.

Connections and sizes in bold are standard



CAUTION

To avoid abnormal operation, accidents or serious injury, DO NOT use this product outside of the specification range. Local regulations may restrict the use of this product to below the conditions quoted.

No.	Description	Material	ASTM/AISI*	JIS	
①	Body	Cast Iron	A126 Cl.B	FC250	
		Cast Steel**	A216 Gr.WCB	—	
②	Cover	Cast Iron	A126 Cl.B	FC250	
		Cast Steel**	A216 Gr.WCB	—	
③	Cover Gasket	Graphite Compound	—	—	
④	Float	Stainless Steel	AISI316L	SUS316L	
⑤	Snap-action Unit	Stainless Steel	—	—	
⑥	Motive Medium Intake Valve Unit	Intake Valve	Stainless Steel	AISI440C	SUS440C
		Valve Seat	Stainless Steel	AISI420F	SUS420F
⑦	Exhaust Valve Unit	Exhaust Valve	Stainless Steel	AISI440C	SUS440C
		Valve Seat	Stainless Steel	AISI420F	SUS420F
⑧	Inlet Check Valve CKF5M	Stainless Steel	AISI304	SUS304	
⑨	Outlet Check Valve CKF3M	Cast Stainless Steel	A351 Gr.CF8	—	

* Equivalent ** Option: Cast Stainless Steel

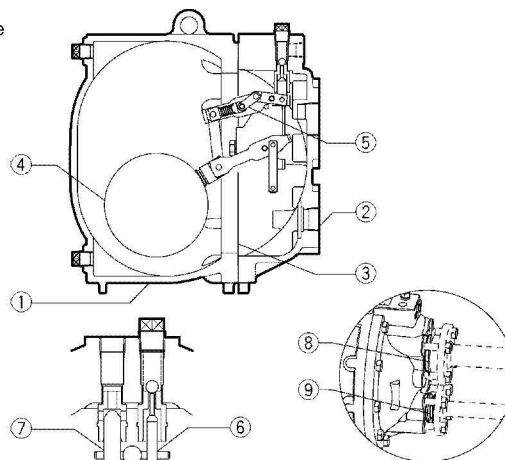

Copyright © TLV

Dimensions

Units: inch

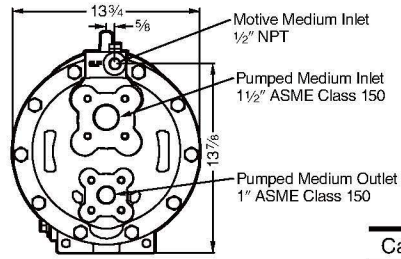
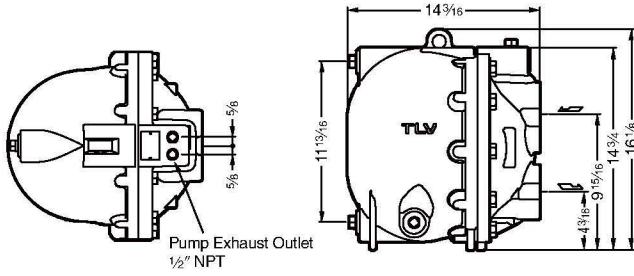

Weight (lb)

Cast Iron	122
Cast Steel	133

Note: All Plug Holes 1/2" NPT

Discharge Capacity

Filling Head 25" from Grade

Inlet Pipe Size		1 1/2"	
Inlet Check Valve		1 1/2" CKF5M	
Outlet Check Valve		1" CKF3M	
Motive Medium		Air	Steam
Motive Medium Inlet Pressure (P _m) (psig)	Total Lift or Back Press. (P ₂) psig	lb/h	lb/h
150	15	5080	5070
	25	4460	4440
	40	4155	3740
	60	3490	2840
	80	3080	2420
	100	2730	1650
125	15	4400	4580
	25	4290	3890
	40	3970	3210
	60	3200	2430
	80	2720	1940
	100	2420	1280
100	15	4210	4160
	25	4080	3480
	40	3770	2730
	60	3120	1920
	80	2660	1410
75	15	3990	3880
	25	3860	3050
	40	3570	2210
	60	3010	1430
50	10	4200	3870
	15	3900	3460
	25	3790	2490
	40	3290	1600
25	5	4470	3940
	10	4030	3010
	15	3680	2400
10	2	4100	3300

● **Correction Factors**

For GP10M installed with filling head other than 25" (minimum filling head: 12")

Filling Head from Grade	Inlet Pipe & Check Valve Size
	1 1/2" CKF5M
55"	1.10
43"	1.08
37"	1.07
31"	1.04
25"	1.00
22"	0.95
18"	0.86
12"	0.60

● **Illustration of Filling Head and Pressures**

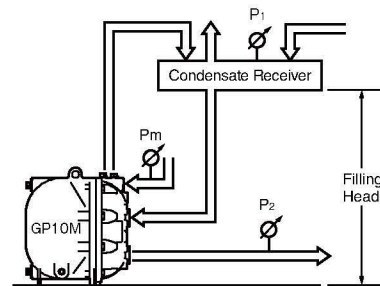

The discharge capacity is determined by the motive medium, motive medium pressure (P_m) and back pressure (P₂).

Make sure that:
 Discharge Capacity × Correction Factor
 > Required Flow Rate

NOTE:

- A check valve must be installed at both the pumped medium inlet and outlet. To achieve the above capacities with the standard GP10M configuration, TLV check valves CKF5M for inlet and CKF3M for outlet must be used.
- Motive steam pressure minus back pressure must be greater than 7 psi.
- In closed system applications, the motive medium must be compatible with the liquid being pumped. If a non-condensable gas such as air or nitrogen is used as the motive medium, consult TLV for assistance.
- A strainer must be installed at the motive medium and pumped medium inlets.

Size of Receiver/Reservoir

The receiver/reservoir must have a capacity sufficient to store the condensate produced during the **PowerTrap** operation and discharge. A receiver will generally be larger than a reservoir because it must handle the condensate both as a liquid and as flash steam, and separate one from the other so that only condensate is sent to the **PowerTrap**.

If NO flash steam is present, use dimensions given in table ②. If flash steam is present, compare tables ① & ② and choose the larger resultant size. For all open systems, use table ① to select a suitable vent pipe diameter.

① Receiver Dimensions (Length: 3.5 ft)

Flash Steam up to (lb/h)	Receiver Diameter (in)	Vent Pipe Diameter (in)
50	3	1
75	4	1½
100	4	2
200	6	2½
300	8	3
400	8	4
600	10	4
800	12	6
1,000	14	6
1,400	16	8
1,600	18	8
2,000	20	8

② Reservoir Dimensions

Amount of condensate lb/h	Reservoir diameter (in) and length (ft)						
	1½	2	3	4	6	8	10
500 or less	3.0 ft	2.0					
700	4.0	2.5	1.0				
1,000	5.5	3.5	1.5				
1,200		4.5	2.0	1.0			
1,500			2.5	1.5			
2,000			3.5	2.0			
3,000			4.5	3.0			
4,000			6.5	4.0	1.5		
5,000				5.0	2.5		
6,000				5.5	2.5	1.5	
7,000				6.5	3.0	1.5	
8,000					3.5	2.0	
9,000					4.0	2.5	1.5
10,000					4.5	2.5	1.5
12,000					5.0	3.0	2.0
14,000					6.0	3.5	2.5
16,000					6.5	4.0	2.5
18,000						4.5	3.0
20,000						5.0	3.5

Reservoir length can be reduced by 50% when the motive pressure (Pm) divided by the back pressure (P2) equals 2 or greater (when $P_m \div P_2 \geq 2$).

Steam or Air Consumption (Motive Medium)

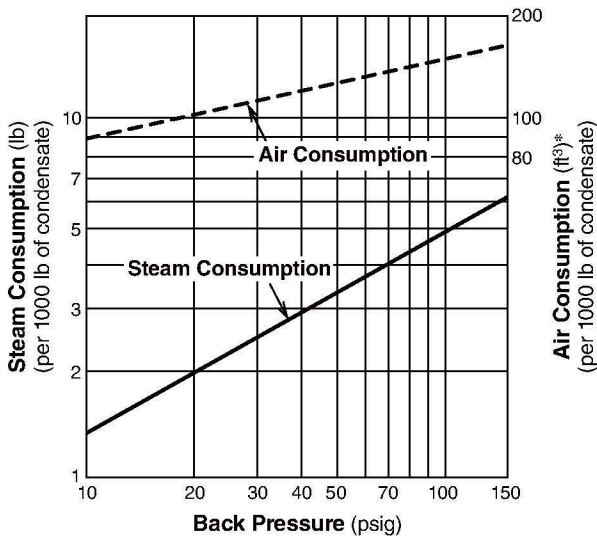

* Equivalent consumption of air at 68 °F under atmospheric pressure

Cycle Counter (option)

Two types of counter can be installed on the GP10M to monitor the number of pumping cycles and help to determine the timing of maintenance, or estimate the volume of pumped condensate.

- **C1CM – (Counter Unit Type):**
Self-contained standalone unit. Includes an LCD counter display and an operation indicator LED.
- **C1SM – (Terminal Box Type):**
Designed for use with remote monitoring equipment and systems.

Intrinsically safe models are also available.
See the Cycle Counter SDS for further details.

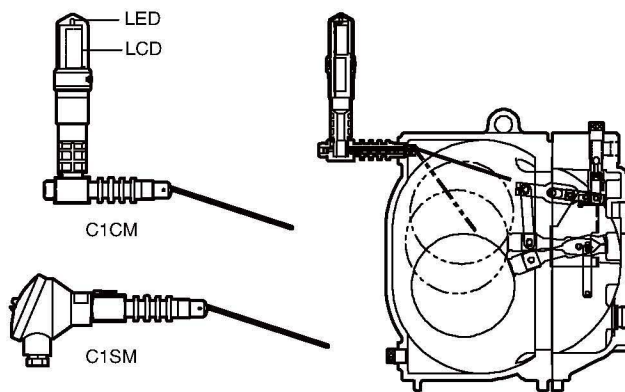

DO NOT DISASSEMBLE OR REMOVE THIS PRODUCT WHILE IT IS UNDER PRESSURE.
Allow internal pressure of this product to equal atmospheric pressure and its surface to cool to room temperature before disassembling or removing. Failure to do so could cause burns or other injury. **READ INSTRUCTION MANUAL CAREFULLY.**

TLV CORPORATION

13901 South Lakes Drive, Charlotte, NC 28273-6790

Phone: 704-597-9070 Fax: 704-583-1610

E-mail: tlv@tlvengineering.com

For Technical Service 1-800 "TLV TRAP"



Manufacturer
TLV CO., LTD.
Kakogawa, Japan
is approved by LRQA Ltd. to ISO 9001/14001

ISO 9001/ISO 14001

