

Mark 87 Series

External Piloted Temperature Regulators

The Mark 87 piloted temperature regulator is the Sliding Gate valve engineered to provide wide rangeability and greater accuracy for a variety of temperature control applications. Designed with the same technology as the industry leading, self-contained Mark 80, the Mark 87 is a piloted temperature regulator that offers quality and performance unparalleled by any competitive products on the market.

OPERATION

The operation of the Mark 87 relies on a unique liquid-vapor combination system. Due to the nature of this type of fill, the thermal operating system is capable of delivering far more operating power than the simple liquid expansion systems used on other temperature regulators. In addition, it is able to operate from the temperature of the process itself and does not require the added expense of temperature controllers or the piping of plant air. This valve is available with both direct acting and reverse acting pilot valves.

The direct acting pilot valve is normally open, allowing upstream pressure to force the main diaphragm down to open the main valve seats. As the process temperature approaches the desired setting, the fluid in the bulb vaporizes, creating the necessary pressure on the pilot diaphragm to throttle the pilot valve toward the closed position. The reverse acting pilot is normally closed and opens on an increase in temperature.

While identical to the Mark 80 in many ways, the piloted Mark 87 can provide more accurate control, and is available in large line sizes (1/2" – 6"). It can be used where larger line sizes and higher flow rates are required. The Mark 87 is available in a wide variety of body materials, end connections, temperature ranges, and bulb configurations.



FEATURES

- Sliding Gate Seats – All of Jordan Valve's pilot-operated temperature regulators feature advanced sliding gate seat technology
 - Straight-through flow for reduced turbulence, longer life and quiet operation
 - Short stroke for fast response and accurate regulation
 - Easily interchangeable Cv's
 - Extended tight shutoff due to wear resistant coatings and overlap of seat closure area



Jordan Valve a division of Richards Industries
3170 Wasson Road • Cincinnati, OH 45209
513.533.5600 • 800.543.7311 • 513.871.0105 (f)
info@richardsind.com • www.jordanvalve.com

SPECIFICATIONS

Sizes: 1/2" through 6" (DN15 through DN150)

End Connections

- Threaded
- Companion Flanges (1/2" – 2") (DN15 – DN50)
- Integral Flanges (2-1/2" – 6") (DN65 – DN150)

Body Materials

- Ductile Iron
- Cast Iron
- Carbon Steel
- Stainless Steel

Trim Materials

- 303SS for DI, BRZ & CS body valves
- 316SS for SS body valves

Seat Materials

- Jorcote on SST – Standard
- Jorcote/Jordanic on SST – For severe service
- Chrome Plated SST – Optional (1/2" - 2" only)

Diaphragm: Stainless Steel

Stem Packing

- Spring-loaded Teflon (500°F max/260°C)
- Braided (above 500°F/260°C)

Thermal System

- Actuator: Type SWA, 304SS
- Capillary: 8' (2,4 m) copper standard. Available up to 100' (30,5 m) in Stainless Steel

Armor

- SST – standard
- Other materials upon request

Sensing Bulb

- Copper – standard
- SST – optional
- Other materials upon request

Shutoff: ANSI Class IV

Temperature Gauge: Optionally mounted on pilot actuator (87T)

Action

- Direct (increase in temperature closes valve — fails open)
- Reverse (increase in temperature opens valve — fails closed)

Body Rating: Ductile Iron up to 725 psi (50 bar) (except 2-1/2" – 6") & 650°F (343°C); Cast Iron up to 500 psi (35 bar) & 450°F (232°C); Carbon Steel and Stainless Steel up to 725 psi (50 bar) (except 2-1/2" – 6") & 650°F (343°C) depending upon specific construction. -20°F (-29°C) temperature limits on all materials. For other temperatures, please consult factory.

Temperature Control Ranges

10 - 55°F (-12 - 13°C)	35 - 90°F (2 - 32°C)	55 - 115°F (13 - 46°C)	80 - 140°F (27 - 60°C)
120 - 185°F (49 - 85°C)	160 - 225°F (71 - 107°C)	205 - 260°F (96 - 127°C)	230 - 290°F (110 - 143°C)
265 - 325°F (129 - 163°C)	315 - 400°F (157 - 204°C)	375 - 440°F (190 - 227°C)	

Note: a minimum pressure differential of 25 psi (1,7 bar) from valve inlet to outlet is required in order for the valve to operate properly. Consult factory if lower differential exists.

Overheat Protection: 100°F (37,7°C) over top of range

Cv (Kv) Values & Maximum Differential Pressures

Valve Size		Flow Coefficient		Seat Material	Max ΔP	
Inches	DN	Cv	Kv		PSI	Bar
1/2"	15	5	4,3	SST	125	8,6
				Jorcote	150	10,3
3/4"	20	9.5	8,2	SST	125	8,6
				Jorcote	150	10,3
1"	25	15	12,9	SST	75	5,2
				Jorcote	150	10,3
1-1/4"	32	25	21,5	SST	75	5,2
				Jorcote	150	10,3
1-1/2"	40	30	25,8	SST	75	5,2
				Jorcote	150	10,3
2"	50	50	43	SST	75	5,2
				Jorcote	150	10,3
2-1/2"	65	55	47,3	Jorcote	150	10,3
3"	80	115	99	Jorcote	150	10,3
4"	100	200	172	Jorcote	150	10,3
6"	150	395	340	Jorcote	150	10,3

* Low flow trim available with Cv 2.5 (Kv 2,15) being the lowest permissible value

Bulb and Well Dimensions

Bulb/Well Type	Nominal Bulb Size (diameter x length)*	
	101°F (38,3°C) or above	100°F (37,7°C) or below
Bulb Type A & B	1" x 12" (25mm x 305mm)	1" x 14" (25mm x 356mm)
	3/4" x 23" (optional) (19mm x 584mm)	3/4" x 27" (optional) (19mm x 686mm)
Bulb Type C	1" x 12" (SST only) (25mm x 305mm)	1" x 14" (SST only) (25mm x 356mm)
	1-1/8" x 14" (Copper only) (29mm x 356mm)	1-1/8" x 14" (Copper only) (29mm x 356mm)
Bulb Type D - E - F	1" x 12" (25mm x 305mm)	1" x 14" (25mm x 356mm)
Well Type A (Standard)	To fit bulb with 1" NPT tank fitting	
Well Type B (Flanged)	To fit bulb with 1-1/2" or 2" x 150/300# flange	

Also Available: Jordan also makes the MK87P, which utilizes a pressure pilot as well as a temperature pilot. Consult factory for details.

FEATURES & BENEFITS

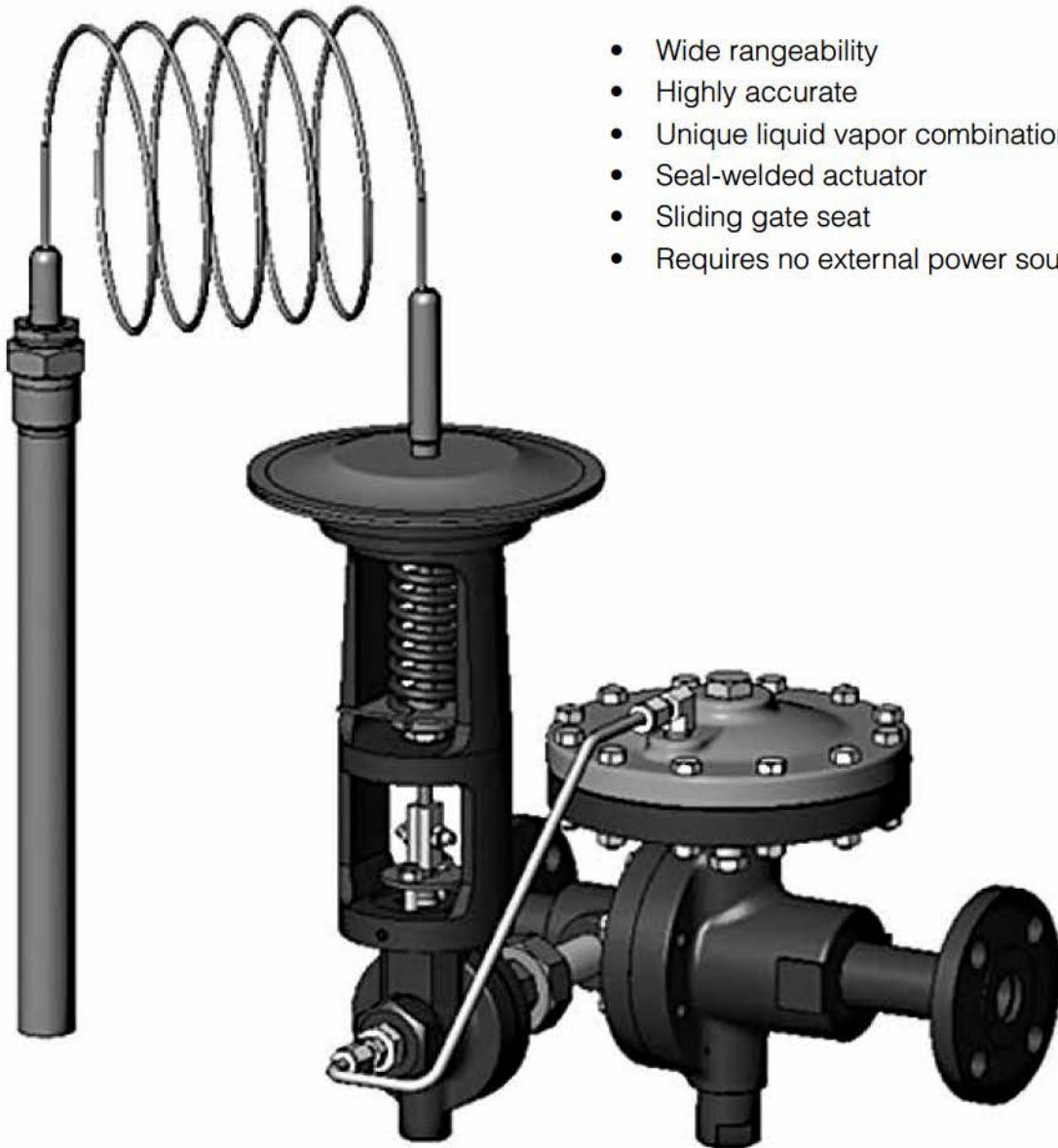

- Wide rangeability
- Highly accurate
- Unique liquid vapor combination system
- Seal-welded actuator
- Sliding gate seat
- Requires no external power source

DIMENSIONS (1/2" – 2")

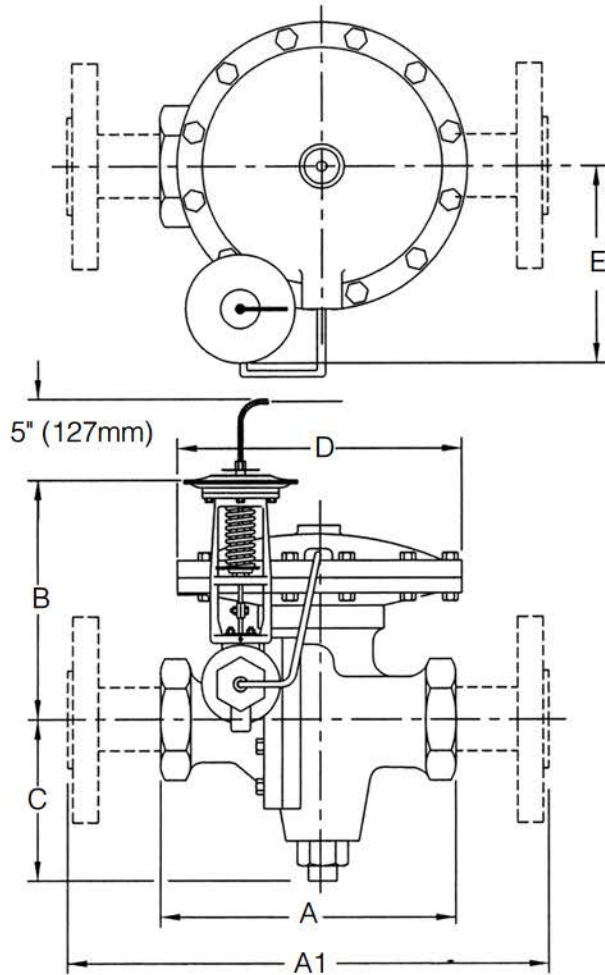

- Threaded Ends, metric

Valve Size	Material	Dimensions (mm)					Weight kgs
		A	B	C	D	E	
15	CS/SS	5.50	305	89	181	254	21,7
	CI/DI	5.31					
20	CS/SS	5.50	305	89	181	254	23,1
	CI/DI	5.31					
25	CS/SS	6.50	305	92	181	254	26,3
	CI/DI	5.68					
32	CS/SS	6.45	305	95	181	254	26,3
	CI/DI	5.85					
40	CS/SS	8.18	305	127	270	292	40,8
	CI/DI	8.18					
50	CS/SS	8.18	305	127	270	292	41,7
	CI/DI	8.18					

- Flanged Ends

Valve Size	ANSI Flange	Dimensions (Inches)					Weight lbs
		A1	B	C	D	E	
1/2"	150#	11.50	12.00	3.50	7.12	10.00	52
	300#	11.50	12.00	3.50	7.12	10.00	52
3/4"	150#	11.50	12.00	3.50	7.12	10.00	59
	300#	11.50	12.00	3.50	7.12	10.00	59
1"	150#	11.50	12.00	3.62	7.12	10.00	64
	300#	11.50	12.00	3.62	7.12	10.00	64
1-1/4"	150#	11.50	12.00	3.75	7.12	10.00	66
	300#	11.50	12.00	3.75	7.12	10.00	66
1-1/2"	150#	14.50	12.00	5.00	10.62	11.50	102
	300#	14.50	12.00	5.00	10.62	11.50	102
2"	150#	14.50	12.00	5.00	10.62	11.50	106
	300#	14.50	12.00	5.00	10.62	11.50	106

- Threaded Ends

Valve Size	Material	Dimensions (Inches)					Weight lbs
		A	B	C	D	E	
1/2"	CS/SS	5.50	12.0	3.50	7.12	10.0	48
	CI/DI	5.31					
3/4"	CS/SS	5.50	12.0	3.50	7.12	10.0	53
	CI/DI	5.31					
1"	CS/SS	6.50	12.0	3.62	7.12	10.0	58
	CI/DI	5.68					
1-1/4"	CS/SS	6.45	12.0	3.75	7.12	10.0	58
	CI/DI	5.85					
1-1/2"	CS/SS	8.18	12.0	5.00	10.62	11.5	90
	CI/DI	8.18					
2"	CS/SS	8.18	12.0	5.00	10.62	11.5	92
	CI/DI	8.18					

- Flanged Ends (metric)

Valve Size	Flange DIN*	Dimensions (mm)					Weight kgs
		A1	B	C	D	E	
15	10/16	292	305	89	181	254	23,6
	25/40	292	305	89	181	254	23,6
20	10/16	292	305	89	181	254	26,8
	25/40	292	305	89	181	254	26,8
25	10/16	292	305	92	181	254	29,0
	25/40	292	305	92	181	254	29,0
32	10/16	292	305	95	181	254	29,9
	25/40	292	305	95	181	254	29,9
40	10/16	368	305	127	270	292	46,3
	25/40	368	305	127	270	292	46,3
50	10/16	368	305	127	270	292	48,1
	25/40	368	305	127	270	292	48,1

* Not per DIN3202

MARK 87 EXTERNALLY PILOTED TEMPERATURE REGULATOR

DIMENSIONS (2-1/2" – 6")

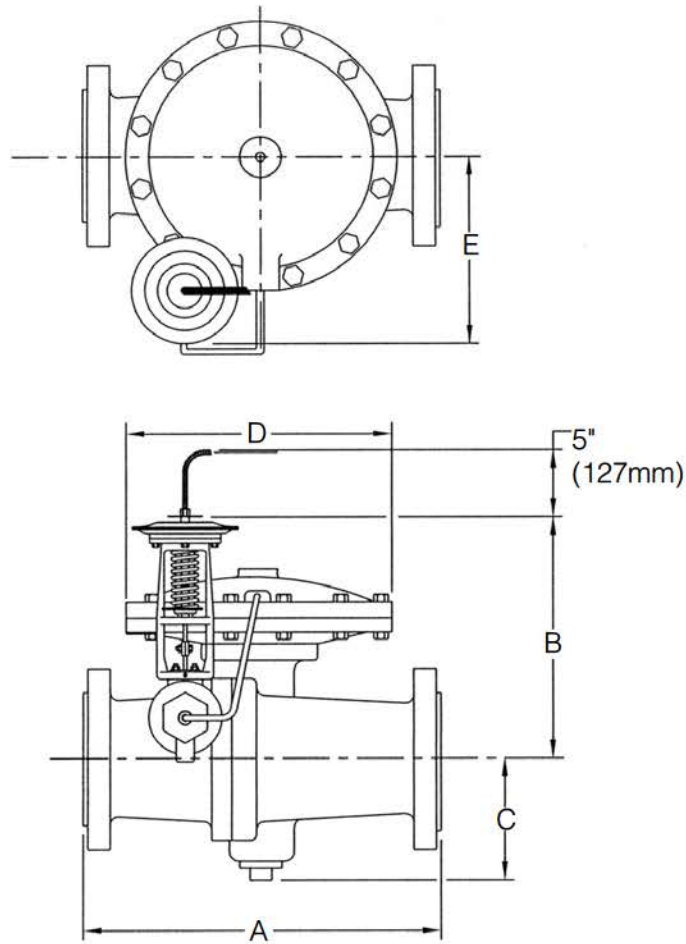

• Flanged Ends

Valve Size	ANSI Flange	Dimensions (Inches)					Weight lbs
		A1	B	C	D	E	
2-1/2"	150#	10.87	13.25	6.93	12.75	11.00	140
	300#	11.50	13.25	6.93	12.75	11.00	
3"	150#	11.75	13.25	6.93	12.75	11.50	160
	300#	12.50	13.25	6.93	12.75	11.50	
4"	150#	13.87	12.00	8.00	12.75	13.00	200
	300#	14.50	12.00	8.00	12.75	13.00	
6"	150#	17.75	12.00	9.00	12.75	13.50	290
	300#	18.62	12.00	9.00	12.75	13.50	

• Flanged Ends (metric)

Valve Size	ANSI Flange	Dimensions (Inches)					Weight lbs
		A1	B	C	D	E	
65	10/16	287	336	176	324	279	63,5
	25/40	292	336	176	324	279	63,5
80	10/16	313	336	176	324	292	72,6
	25/60	313	336	176	324	292	72,6
100	10/16	353	305	203	324	330	90,7
	25/40	353	305	203	324	330	90,7
150	10/16	473	305	229	324	343	131,5
	25/60	473	305	229	324	343	131,5

* Not per DIN3202

ORDERING SCHEMATIC

Model No	Size	Body Mat'l	1	2	3	4	5	6	7	8	9	10	11	12	13	14	15	16

Model	
87	Standard
87T	with Temperature Gauge

Size	
050	1/2" (DN15)
075	3/4" (DN20)
100	1" (DN25)
125	1-1/4" (DN32)
150	1-1/2" (DN40)
200	2" (DN50)
250	2-1/2" (DN65)
300	3" (DN80)
400	4" (DN100)
600	6" (DN150)

Body Material	
DI	Ductile Iron
CS	Carbon Steel (WCB)
S6	Stainless Steel (CF8M)
CI	Cast Iron

1 & 2	End Connections
PT	NPT
BT	BSPT
BP	BSPP
SW	FSW
I5	150# IFE CS or SST valves
I3	300# IFE CS or SST valves
I7	IFE PN10 CS or SST valves
I6	IFE PN16 CS or SST valves
I8	IFE PN25 CS or SST valves
I4	IFE PN40 CS or SST valves

3 & 4	Trim Material
C3	303SS/CU Tubing
S3	303SS
S6	316SS
L1	303SS 5-10 DP
L2	316SS 5-10 DP
L3	303SS 10-15 DP
L4	316SS 10-15 DP
L5	303SS 15-20 DP
L6	316SS 15-20 DP

5	Seat Material
V	303SS/Jorcote
W	316SS/Jorcote
A	303 SST
B	316 SST

6	Cv (Kv)		
K	5.0 (4,3)	V	35 (30,1)
8	9.5 (8,2)	C	50 (43,0)
9	15 (12,9)	D	55 (47,3)
A	25 (21,5)	G	115 (98,9)
B	30 (25,8)	I	200 (172)
		J	395 (340) (6")

7 & 8	Range		
06	-20 to 20°F	58	160 to 225°F
12	10 to 55°F	66	205 to 260°F
19	35 to 90°F	72	230 to 290°F
27	55 to 115°F	81	265 to 325°F
35	80 to 140°F	88	315 to 400°F
42	110 to 165°F	93	380 to 450°F
49	120 to 185°F		

9 & 10	Thermowell
	Type, Fitting, & Mat'l
	Size: For Bulb Dia x Length
A	Type A, 1" NPT, Cu A 1" x 12"
B	Type A, 1" NPT, SST B 1" x 14"
E	Type B, 1-1/2"x150#, SST
F	Type B, 1-1/2"x300#, SST
G	Type B, 2"x150#, SST
H	Type B, 2"x300#, SST
N	None
	Tank Fitting Only
11	1" NPT, Brass for 1" Bulb
12	1" NPT SST for 1" Bulb
NN	None

11 & 12	Bulb		
	Type & Material	Dia x Length	
	Type A & B Bulbs		
A	Type A, Cu	1	1" x 12"
G	Type A, SST	2	1" x 14"
H	Type B, SST	3	1" x 17"

13 & 14	Capillary/Armor		
	Material	Length	
A	Copper	1	8' (2,4 m)
B	SST	2	10' (3,0 m)
		3	12' (3,7 m)
		4	15' (4,6 m)
		5	20' (6,1 m)

15	Actuator
A	Standard
R	SWA/Reinforced (Required below 0°F)

16	Action
D	Direct
R	Reverse