

TU5 SERIES TURBIDIMETERS

Applications

- Drinking Water
- Power
- Beverage
- Pharmaceutical



The next standard in the evolution of turbidity

Only the new TU5 Series Lab & Process Turbidimeters with 360° x 90° Detection™ deliver unprecedented confidence that a change in your reading is a change in your water.

Groundbreaking 360° x 90° Detection™ Technology

The TU5 Series employs a patented optical design that sees more of your sample than any other turbidimeter, delivering the best low level precision and sensitivity while minimizing variability from test to test.

Matching lab and online results

For the first time you will be able to remove the uncertainty of which measurement to trust, thanks to identical 360° x 90° Detection™ Technology in both instruments.

Everything about turbidity – faster

The TU5 Series dramatically reduces the time needed to get a turbidity measurement you can rely on, with 98% less online sample surface area to clean, sealed vials for calibration, and the elimination of the need for indexing and silicone oil in the lab. Not to mention, a smaller online sample volume means you will detect events almost immediately.

No surprises

Prognosis™ monitors your TU5 Series online instrument, proactively alerting you to maintenance needs before your measurement becomes questionable. And a Hach Service Agreement protects your investment and helps ensure that you stay in compliance and on budget.

USEPA and ISO 7027 reporting: The TU5 Series Turbidimeters apply the instrument design and meet performance criteria established by EPA Approved Hach Method 10258 and ISO 7027-1:2016, making them suitable for regulatory reporting.



Be Right™

Technical Data*

TU5200

Light Source	Class 2 laser product, with embedded 650 nm (EPA 0.43 mW) or Class 1 laser product, with embedded 850 nm (ISO), max. 0.55 mW (complies with IEC/EN 60825-1 and to 21 CFR 1040.10 in accordance with Laser Notice No. 50)
Range	EPA: 0 - 700 NTU / FNU / TE/F / FTU 0 - 100 mg/L 0 - 175 EBC ISO: 0 - 1000 NTU / FNU / TE/F / FTU 0 - 100 mg/L 0 - 250 EBC
Accuracy	±2 % plus 0.01 NTU from 0 - 40 NTU; ±10 % of reading from 40 - 1000 NTU based on Formazin primary standard (at 25 °C)
Resolution	0.0001 NTU / FNU / TE/F / FTU / EBC / mg/L
Repeatability	<40 NTU: Better than 1% of reading or ±0.002 NTU on Formazin at 25 °C, whichever is greater >40 NTU: Better than 3.5% of reading on Formazin at 25 °C
Stray Light	<10 mNTU
Units	NTU, FNU, TE/F, FTU, EBC; mg/L if calibrated with Degrees calibration curve
Operating Temperature Range	10 - 40 °C (50 - 104 °F)
Operating Humidity	80% at 30 °C (non condensing)
Sample Temperature	4 - 70 °C (39 - 158 °F)
Storage Conditions	-30 - 60 °C (-22 - 140 °F)
Power Requirements (Voltage)	100 - 240 VAC
Power Requirements (Hz)	50/60 Hz
Certifications	CE compliant US FDA accession number: 1420493-000 EPA version, 1420492-000 ISO version Complies with IEC/EN 60825-1 and to 21 CFR 1040.10 in accordance with Laser Notice No. 50) Australian ACMA Marking
Dimensions (H x W x D)	195 mm x 409 mm x 278 mm
Weight	2.4 kg (5.29 lbs.)
Warranty	1 year

TU5300 sc / TU5400 sc

Light Source	Class 2 laser product, with embedded 650 nm (EPA 0.43 mW) or Class 1 laser product, with embedded 850 nm (ISO), max. 0.55 mW (complies with IEC/EN 60825-1 and to 21 CFR 1040.10 in accordance with Laser Notice No. 50)
Range	EPA: 0 - 700 NTU / FNU / TE/F / FTU 0 - 100 mg/L 0 - 175 EBC ISO: 0 - 1000 NTU / FNU / TE/F / FTU 0 - 100 mg/L 0 - 250 EBC
Accuracy	±2% or 0.01 NTU from 0 - 40 NTU ±10% of reading from 40 - 1000 NTU based on Formazin primary standard
Resolution	0.0001 NTU / FNU / TE/F / FTU / EBC
Repeatability	Better than 1% of reading or ±0.002 NTU (TU5300) or ±0.0006 NTU (TU5400) on Formazin at 25 °C (77 °F), whichever is greater
Stray Light	<10 mNTU
Units	NTU, FNU, TE/F, FTU, EBC
Signal Average Time	5 - 90 seconds
Response Time	T90 <30 seconds at 100 mL/min
Sample Temperature	2 - 60 °C (35 - 140 °F)
Sample Pressure	6 bar (87 psi) maximum, compared to air at sample temperature range from 2 - 40 °C (35.6 - 104 °F)
Sample Flow Rate	100 - 1000 mL/min; optimal flow rate: 200 - 500 mL/min
Operating Temperature Range	0 - 50 °C (32 - 122 °F)
Operating Humidity	Relative humidity: 5 - 95% at different temperatures, non-condensing
Storage Conditions	-40 - 60 °C (-40 - 140 °F)
Certifications	CE compliant US FDA accession number: 1420493-000 EPA version, 1420492-000 ISO version Complies with IEC/EN 60825-1 and to 21 CFR 1040.10 in accordance with Laser Notice No. 50) Australian ACMA Marking
Dimensions (H x W x D)	249 mm x 268 mm x 190 mm
Weight	5.95 lbs. (2.7 kg); 11 lbs. (5.0 kg) with all accessories
Warranty	1 year

*Subject to change without notice.

Principle of Operation

The TU5 Series turbidimeters measure turbidity by directing a laser into a sample to scatter off suspended particles. The light that is scattered at a 90° angle from the incident beam is reflected through a conical mirror in a 360° ring around the sample before it is captured by a detector.

The amount of light scattered is proportional to the turbidity of the sample. If the turbidity of the sample is negligible, little light will be scattered and detected by the photocell and the turbidity reading will be low. High turbidity, on the other hand, will cause a high level of light scattering and result in a high reading.

The 360° x 90° optics of the TU5 series were optimized for high accuracy at low turbidity ranges and therefore the TU5 does not include ratio technology. Ratio technology is only applicable for high turbidity applications which have interference from color and large particles.

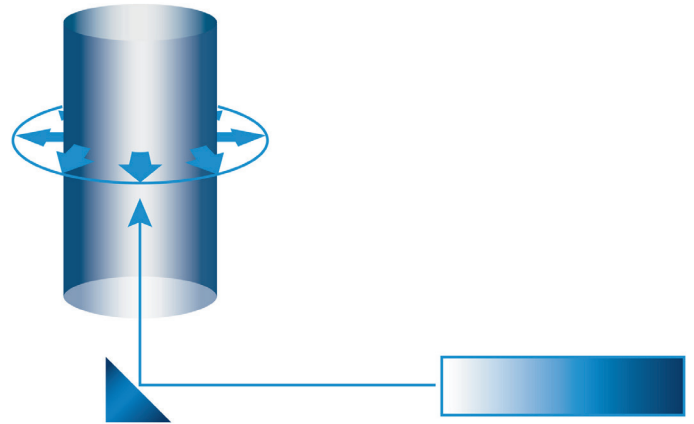

Dimensions

TU5300 sc and TU5400 sc front view

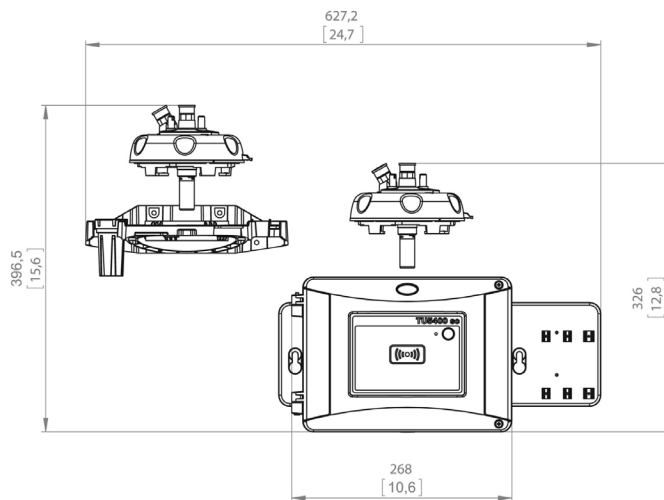

TU5300 sc and TU5400 sc rear view

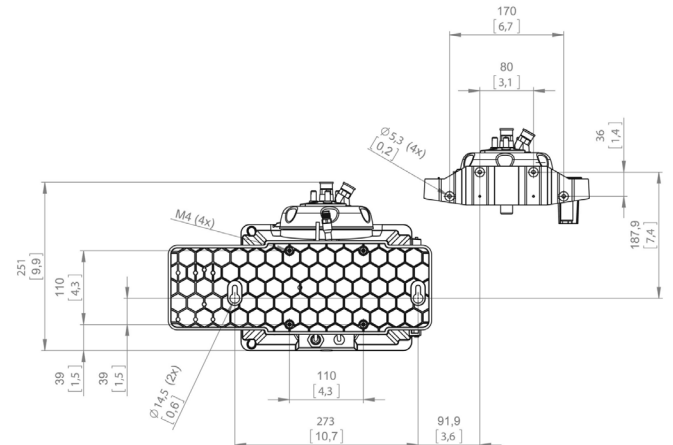

TU5300 sc and TU5400 sc top view

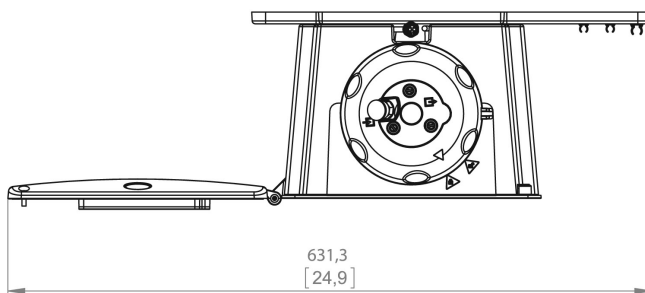

TU5300 sc and TU5400 sc with automatic cleaning module

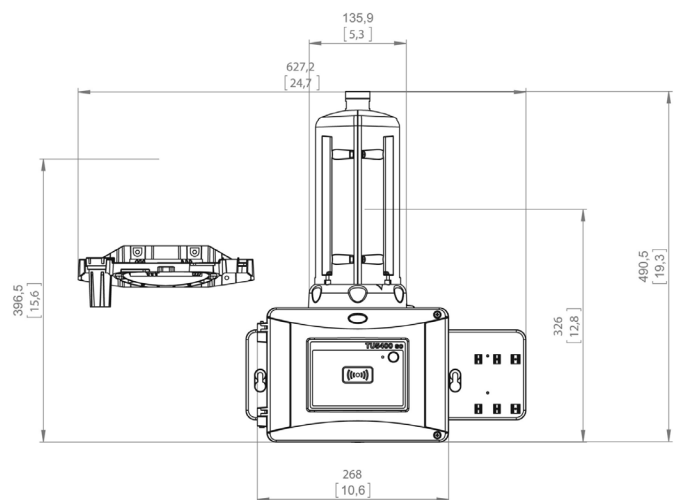

Order Information

TU5200 Benchtop Laser Turbidimeters

- LPV442.99.03012** TU5200 Benchtop Laser Turbidimeter with RFID, EPA Version
LPV442.99.01012 TU5200 Benchtop Laser Turbidimeter without RFID, EPA Version
LPV442.99.03022 TU5200 Benchtop Laser Turbidimeter with RFID, ISO Version
LPV442.99.01022 TU5200 Benchtop Laser Turbidimeter without RFID, ISO Version

TU5300 sc/TU5400 sc Online Laser Turbidimeters

- LXV445.99.10112** TU5300 sc Low Range Laser Turbidimeter, EPA Version
LXV445.99.10212 TU5400 sc Ultra-High Precision Low Range Laser Turbidimeter, EPA Version
LXV445.99.53112 TU5300 sc with Flow Sensor, Automatic Cleaning, RFID, and System Check, EPA Version
LXV445.99.53212 TU5400 sc with Flow Sensor, Automatic Cleaning, RFID, and System Check, EPA Version

Please note: Other turbidimeter configurations are available and RFID may not be available in all areas. Please contact your local Hach representative.

Please note: an SC controller is required for operation of the TU5300 sc or TU5400 sc.

Calibration and Verification

- LZY835** Stabcal® Calibration Set with RFID
LZY898 Stabcal® Calibration Set without RFID
LZY901 Glass Rod Secondary Turbidity Standard <0.1 NTU/FNU
LZY834 Replacement Vial for TU5300 sc and TU5400 sc
LZV946 Sample Vials for TU5200

TU5 Series Accessories

- LQV159.97.00002** Automatic Cleaning Module for TU5300 sc and TU5400 sc
LQV160.99.00002 Flow Sensor for TU5300 sc and TU5400 sc
LZY876 Desiccant Cartridge for TU5300 sc and TU5400 sc
LZY907.97.00002 Maintenance Kit for TU5300 sc and TU5400 sc
LQV157.99.50002 SIP10 Sipper Unit for TU5200
LZY903 Manual Vial Wiper for TU5200, TU5300 sc, and TU5400 sc

Service Options

Start-Up:

Instrument start-up, Basic instrument training to help you learn how to use your instrument from the first day you use it.

Service Agreement:

Hach offers a wide range of agreements for bench or field service to help you maximize your measurement reliability and instrument uptime.

Contact us to learn about what Hach Service option is right for you.



HACH COMPANY World Headquarters: Loveland, Colorado USA

United States: 800-227-4224 tel 970-669-2932 fax orders@hach.com

Outside United States: 970-669-3050 tel 970-461-3939 fax int@hach.com

hach.com

Printed in U.S.A.

©Hach Company, 2017. All rights reserved.

In the interest of improving and updating its equipment, Hach Company reserves the right to alter specifications to equipment at any time.



Be Right™