

# Mark 5850HP Series

## High Back Pressure Regulator

### HIGH BACK PRESSURE REGULATORS

The Mark 5850HP is a high pressure, back pressure regulator designed to maintain upstream pressure of gases and liquids. As a compact, lightweight product, it is well suited for applications where space and weight are at a premium.

With a robust piston design, the MK5850HP can handle setpoints up to 5000 psig (345 bar) at 450°F (232°C) with ease. The T-bar adjusting handle allows convenient, precise final setpoint adjustment.

The valve is normally closed, with the soft seat maintaining ANSI Class VI shutoff. When the inlet rises above the spring setpoint, the pressure forces the piston upwards to open and relieve the pressure. As the inlet pressure falls to the spring setpoint, the valve then throttles to the closed position.

Among other applications, the MK5850HP can be used for:

- high pressure vessel venting
- high pressure injection applications
- gas/liquid sampling stations
- compressor skids
- test stands

#### Features:

- Complete barstock construction – ensures body/trim material quality and facilitates usage of alloy materials
- High flow – Cv 0.4 (Kv 0,34) in a compact design
- Full pressure rating across entire temperature range – maximum setpoints available at maximum pressures
- T-bar handle – allows convenient, precise final setpoint adjustment
- Proof-tested to 20,000 psi (1380 bar) – five times pressure rating, ensures safety when working with high pressures
- A variety of seal materials ensure compatibility with medium



**MK5850HP HIGH BACK PRESSURE REGULATOR**
**SPECIFICATIONS**

Line Size: 1/2" (DN15)

**End Connections**

- Threaded
- Socket Weld
- Flanged (welded)

**Standard Materials**

- Body/Spring Housing: 316L Stainless Steel
- Adjusting Screw: Nitronic 60
- Seat: Teflon
- Orifice: 316L Stainless Steel
- Piston: Nitronic 60
- Cylinder: 316L Stainless Steel
- O-Rings: Buna-N (-65°F to 250°F/-54°C to 121°C); EPDM (-20°F to 450°F/-29°C to 232°C); Viton (15°F to 400°F/-26°C to 204°C)
- Trim Bushings & Seals: Teflon
- Shutoff: Class VI
- For other body/trim materials, please consult factory

**ORDERING SCHEMATIC**

MODEL	
5850HP	Standard

BODY MATERIAL	
316	316 Stainless Steel

O-RING	
B	Buna-N
E	EPDM
V	Viton

1 & 2		BODY	
Size		End Connection	
A	1/2" (DN15)	A	FNPT
		B	FSW
		E	600# Flange
		F	900# Flange
		G	1500# Flange
ZZ		Non-Standard	

**Body Pressure/Temperature**

- 5000 psig @ 100°F (345 bar @ 38°C)
- 3300 psig @ 450°F (228 bar @ 232°C)

Standard Cv: 0.4 (0,34 Kv)

Standard Range: 800 - 5000 psi (55 - 345 bar); for lower setpoints, contact factory

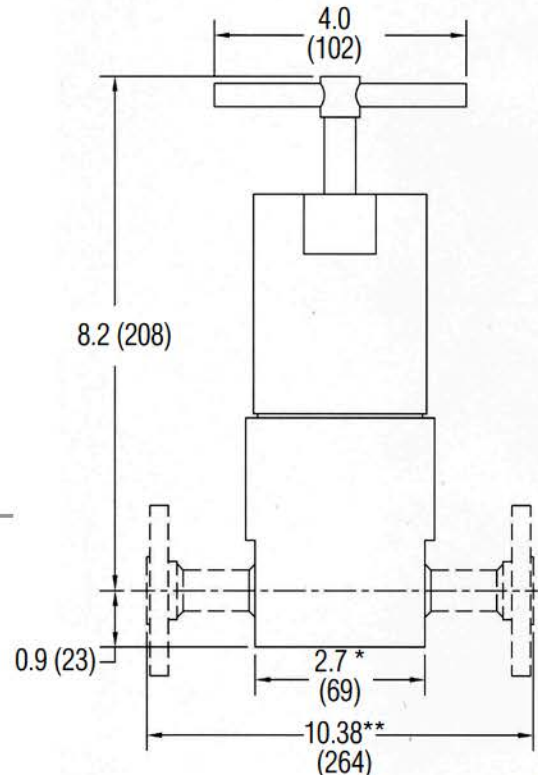
**DIMENSIONS**

\* 1/2" THD, FSW, &amp; BWE Ends, weight 30 lbs (13,6 kgs)

\*\* 1/2" Flanged End, ANSI 2500#, weight 45 lbs (20,5 kgs)

3 & 4 TRIM	
4P	Cv 0.4
ZZ	Non-Standard

5 & 6 SET RANGE	
B9	800 - 5000 psi (55 - 345 bar)
ZZ	Non-Standard

7 & 8 ACCESSORY	
SC	Clean / Oil Free
ZZ	Non-Standard