

# JB Series

## Gas Back Pressure Reducing Valves

### *BACK PRESSURE REDUCING VALVE*

The LowFlow JB Series line of back pressure regulators have the ability to handle very high pressures and very low flows. These valves are typically used in research and sampling systems for corrosive and specialty gases. Typical applications include gas chromatography and flame ionization detectors, as well as other industrial controls.

#### **Features:**

- Top entry design facilitates in-line cleaning and maintenance
- Barstock construction guarantees material integrity and surface finish
- High flow rate coupled with high rangeability reduces need for reduced trim sizes
- Optimized internal volume
- Proprietary Jorlon diaphragm material provides exceptionally long life
- Soft seat material for ANSI Class VI shutoff



## JB SERIES SPECIFICATIONS

**Line Size:** 1/4", 3/8", 1/2" (DN8, DN10, DN15)

**End Connections**

- Threaded
- Socket Weld
- Flanged

**Soft Seat Materials for ANSI Class VI Shut-off**

- PEEK to +350°F (+177°C)
- Kel-F to +250°F (+121°C)

**Seat-To-body O-Ring:**

- Viton - standard
- Consult factory for other materials

**Body Material**

- 316L SST – Standard
- Contact factory for other body/trim/seat materials

**Diaphragm Material:** Jorlon

**Maximum Inlet Pressure:** 1000 psig (68,9 bar) @ -20°F (28,9°C)

**Pressure at Maximum Temperature:**

- 1000 psi @ 350°F (68,9 bar @ 177°C) with PEEK seat
- 1000 psi @250°F (68,9 bar @ 121°C) with Kel-F seat

**Spring Ranges**

- 5 – 50 psi (0,3 – 3,4 bar)
- 25 – 100 psi (1,7 – 6,9 bar)
- 50 – 150 psi (3,4 – 10,3 bar)
- 75 – 250 psi (5,2 – 17 bar)
- 100 – 475 psi (7 – 33 bar)
- 200 – 750 psi (14 – 52 bar)

**Flow Characteristics**

- Cv 0.05
- Cv 0.15
- Cv 0.25
- Cv 0.35

**Options**

- Panel Mounting
- Captured Vent
- Locking Wire
- Tamper Proof
- Lockout Device

## OPTIONS & DEFINITIONS

**Panel Mount** The panel mount feature utilizes a threaded spring housing and a panel mount ring to secure the regulator to an instrument panel. This option requires a 1-1/2" panel cut out.

**Captured Vent** The captured vent design provides maximum safety for the user when handling toxic or hazardous media. It features a 1/8" FNPT port located on the spring housing. The user can easily tube this vent to a safe location. This option can be incorporated into a self-relieving regulator that provides an additional port to permit the safe expulsion of hazardous media.

**Locking Wire** The locking wire option utilizes a lead sealed metal wire to physically hold the adjusting screw in place to prevent any unwanted set point changes.

**Tamper Proof** The tamper proof option replaces the standard adjusting knob with a stainless steel acorn nut.

**Lockout Device** The lockout device is a 2 piece polypropylene enclosure which encapsulates the adjustment knob and prevents unwanted set point changes. The part number required for this valve is 26970. (Lock not included)

**JB SERIES FEATURES & BENEFITS**

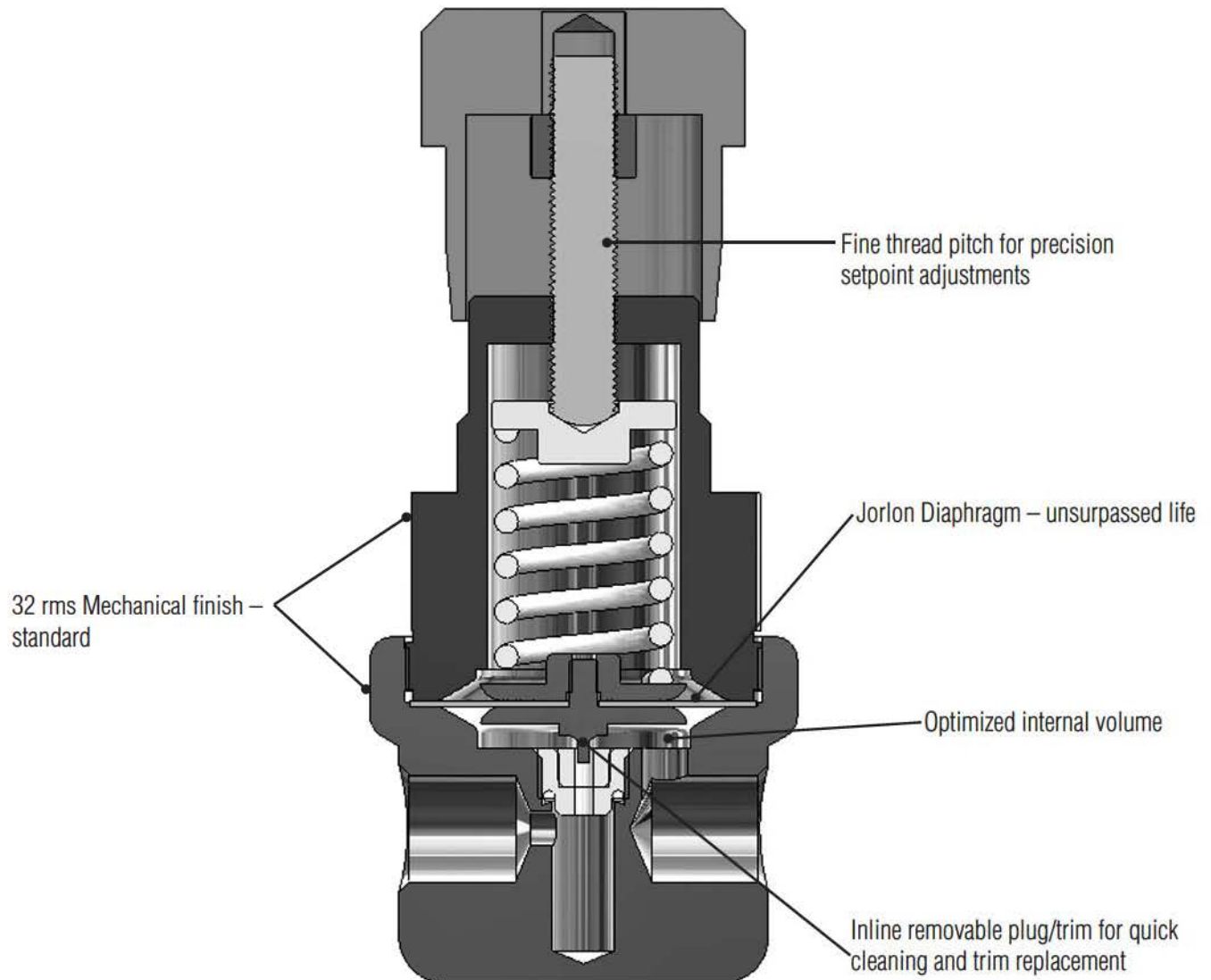

**Sizing**

1. Use the "LVCV Sizing Software" link found on the [www.lowflowvalve.com](http://www.lowflowvalve.com) home page and navigate to LowFlow valve sizing.
2. Use the software to find the appropriate CV for the customer's application conditions.
3. LVCV will tell you the CV needed to pass the required flow. Because the JB works best under 50% capacity, you need to select an install CV for the valve that is at least two times larger.

**Example:**

Air, ambient temperature, P1 = 200 psi, P2 = 0 psi, ½" schedule 40 pipe, flow rate 800 scfh

Using LVCV to size for CV we find that these conditions require an actual CV of 0.11. Calculating for less than 50% capacity we then multiply the result by 2x ( $0.11 \times 2 = 0.22$ ). This means that we should install the 0.25 CV to optimize the valve for the conditions.

**JB SERIES DIMENSIONS**

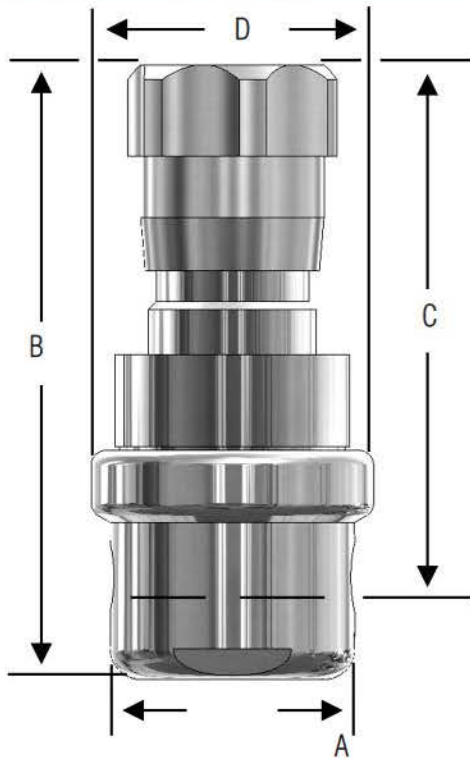

• **JB Series, Inches**

VALVE SIZE	DIMENSIONS, INCHES				WEIGHT LBS
	A	B	C	D	
1/4"	2.00	5.03	4.20	2.31	3.4
3/8"	2.00	5.03	4.20	2.31	3.4
1/2"	2.75	5.03	4.20	2.31	4.2

• **JB Series, Metric**

VALVE SIZE	DIMENSIONS, MM				WEIGHT KGS
	A	B	C	D	
DN8	50,8	128	107	58,7	1,5
DN10	50,8	128	107	58,7	1,5
DN15	69,9	128	107	58,7	1,9

**JB SERIES FLOW CONFIGURATIONS**

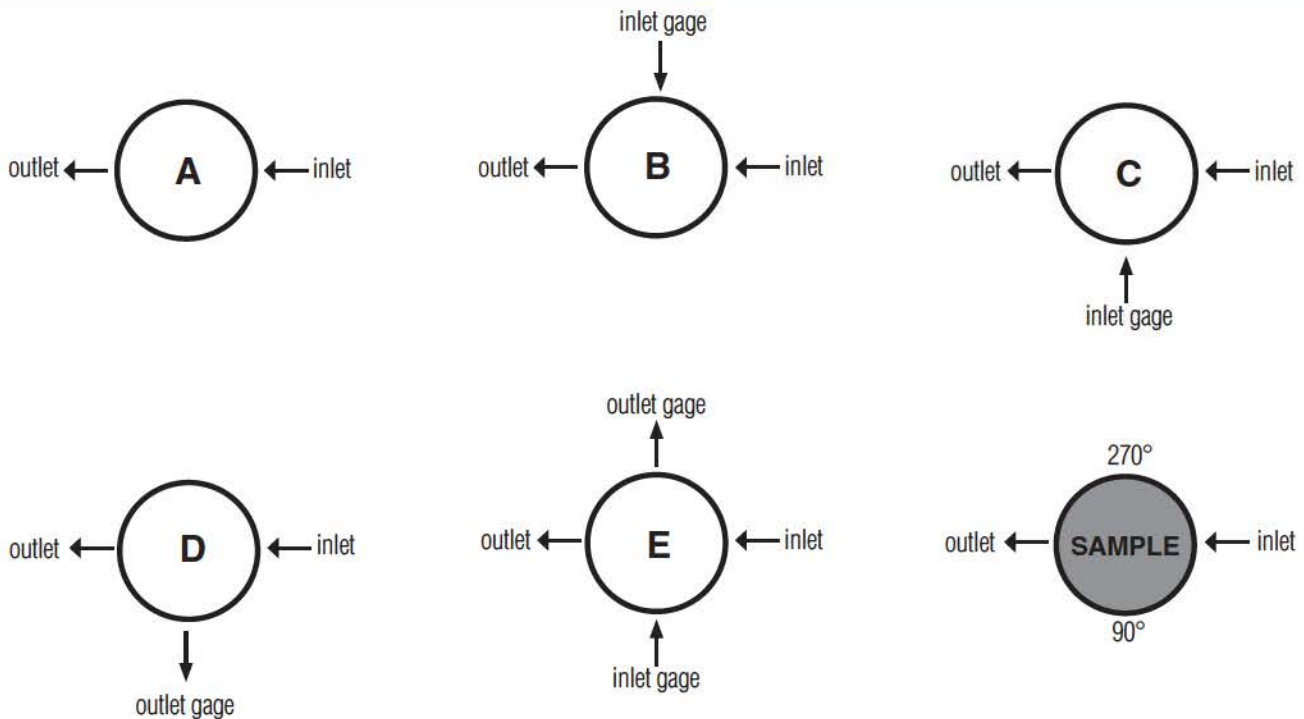

\*Gage ports are 1/4" FNPT (consult factory for required alternative)

Other porting options are available at [www.lowflowvalve.com](http://www.lowflowvalve.com) under the resources tab

**JB SERIES ORDERING SCHEMATIC**

Model	Size	Material	1 & 2	3 & 4	5 & 6	7 & 8	9 & 10	11 & 12	13 & 14	15	16	17
—	—	—	/									

Model	
JB	Back Pressure Regulating Valve

Size	
025	1/4"
038	3/8"
050	1/2"

Material	
6L	Stainless Steel 316L

1 & 2		Body Feature	
End Connection		Port Configuration	
A	FNPT 1/4"	A	Port "A"
B	FNPT 3/8"	B	Port "B"
C	FNPT 1/2"	C	Port "C"
		D	Port "D"
		E	Port "E"
ZZ	Non-Standard		

3 & 4		Trim	
1S		Cv 0.15	
2S		Cv 0.25	
3S		Cv 0.35	
4S		Cv 0.05	
ZZ		Non-Standard	

5 & 6		Seat	
P1		PEEK Cv 0.15	
P2		PEEK Cv 0.25	
P3		PEEK Cv 0.35	
P4		PEEK Cv 0.05	
K1		Kel-F Cv 0.05	
K2		Kel-F Cv 0.15	
K3		Kel-F Cv 0.25	
K4		Kel-F Cv 0.35	
ZZ		Non-Standard	

7 & 8		Range Spring	
E1		5- 50 psi	
E2		25 - 100 psi	
E3		50 - 150 psi	
E4		75 - 250 psi	
E5		100 - 475 psi	
E6		200 - 750 psi	

9 & 10		Diaphragm Material	
JL		Jorlon	
ZZ		Non-Standard	

11 & 12		Actuator	
		Ranges E1 thru E6	
SK		Standard	
CV		Captured Vent	
PM		Panel Mount	
ZZ		Non-Standard	

13 & 14		Inlet Gauge	
AA		0 - 30 psig	
BB		0 - 60 psig/bar (dual)	
CC		0 - 100 psig/bar (dual)	
DD		0 - 160 psig/bar (dual)	
EE		0 - 200 psig/bar (dual)	
FF		0 - 300 psig/bar (dual)	
GG		0 - 400 psig/bar (dual)	
HH		0 - 600 psig/bar (dual)	
JJ		0 - 1000 psi/bar (dual)	
KK		0 - 2000 psi/bar (dual)	
LL		0 - 3000 psi/bar (dual)	
MM		0 - 5000 psi/bar (dual)	
NN		None	
ZZ		Non-Standard	

Continued on next page

**JB SERIES ORDERING SCHEMATIC (CON'T)**

Model	Size	Material		1 & 2	3 & 4	5 & 6	7 & 8	9 & 10	11 & 12	13 & 14	15	16	17
—		—	/										

15	Outlet Gauge
A	0 - 30 psig
B	0 - 60 psig/bar (dual)
C	0 - 100 psig/bar (dual)
D	0 - 160 psig/bar (dual)
E	0 - 200 psig/bar (dual)
F	0 - 300 psig/bar (dual)
G	0 - 400 psig/bar (dual)
H	0 - 600 psig/bar (dual)
J	0 - 1000 psi/bar (dual)
N	None
Z	Non-Standard

16	SEP Compliance
0	None
G	SEP Compliant
Z	Non-Standard

17	Accessories
0	None
S	Clean for Oil Free*
X	Clean for Oxygen*
Z	Non-Standard

\*Consult factory for compatible gauge options