

Mark DBAQ Series

Angle Style Control Valves

The Mark DBAQ Series Control Valves are ideally suited for high pressure water and steam applications, providing excellent pressure and flow control. This design may be utilized in both high pressure and high temperature control service.

The Mark DBAQ is an angle style valve, which may be used in angle piping or self draining applications. The Mark DBAQ Series valves are single port, metal seated valves.

Valve bodies are available in 2" size, with casted flanged connections, and ASME body ratings of Class 1500, or Class 2500.



2" Mark DBAQ Series

FEATURES

- Angle Design
- Equal percentage flow characteristic is standard
- High pressure capability
- The Mark DBAQ Series is suitable for high pressure or high temperature service
- Ideal for high pressure water and steam applications
- Optional body and trim materials are available
- Sour service capability: Optional NACE MRO175/ ISO 15156-2009
- Tight shutoff



Jordan Valve, a division of Richards Industries
3170 Wasson Road • Cincinnati, OH 45209
513.533.5600 • 800.543.7311 • 513.871.0105 (f)
info@richardsind.com • www.jordanvalve.com

SPECIFICATIONS

Size: 2"

End Connections:

- ASME Class 1500 and 2500
- Raised Face (RF), Ring Type Joint (RTJ), National Pipe Thread (NPT), or Butt Weld as per ASME B16.34-latest edition

Body Materials:

- LCC
- WCB
- CF8M (316SS)
- Additional materials may be available upon request

Trim Materials:

- 316SST
- 416SST
- 17-4PH
- Alloy6-Co.Cr-A
- Cobalt
- 316/Tungsten Carbide

Seats: Metal

Shutoff: Class IV and V

Maximum Inlet Pressures and Temperatures:

- Raised face Flange: Consistent with Class 1500 or Class 2500 per ASME B16.34-latest edition
- Ring Type Joint: Consistent with Class 1500 or Class 2500 per ASME B16.34-latest edition

Maximum Pressure Drops: All Valves are Capable of Full Rated Pressure Drops

Flow Characteristics: Equal percentage

Flow Direction: Flow Up through the seat ring and out through the cage

Valve Travel Indication: Valves are Supplied with Visual Travel Indicator

MARK DBAQ SERIES ANGLE STYLE CONTROL VALVES

MARK DBAQ SERIES – PRODUCT BULLETIN: DIMENSIONS

Nominal Body Size Inch	A				D			
	Class 900/1500		Class 2500		Std Bonnet		Ext. Bonnet	
	RF, Flanged, or Weld Ends	RTJ Flanged Ends	RF, Flanged, or Weld Ends	RTJ Flange Ends	1/2" (12.7mm) Stem	3/4" (19.1mm) Stem	1/2" (12.7mm) Stem	3/4" (19.1mm) Stem
	Inches							
2	7.00	7.06	7.69	7.75	9.75	10.50	16.81	17.44
	mm							
2	179	179	195	197	248	267	427	443

Nominal Body Size Inch	D			
	Class 2500			
	Std Bonnet		Ext. Bonnet	
	1/2" (12.7mm) Stem	3/4" (19.1mm) Stem	1/2" (12.7mm) Stem	3/4" (19.1mm) Stem
	Inches			
2	8.25	9.00	15.31	15.94
	mm			
2	210	229	389	405

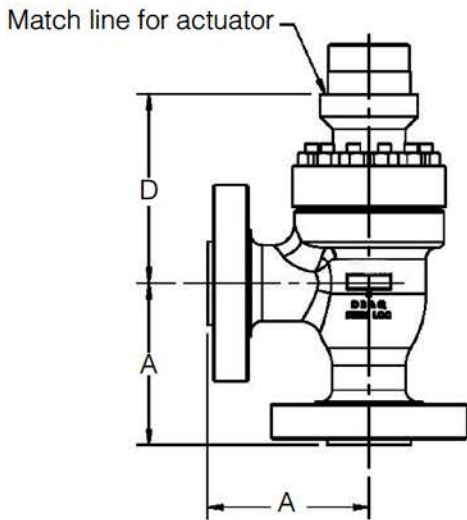

Mark DBAQ – Plain Bonnet

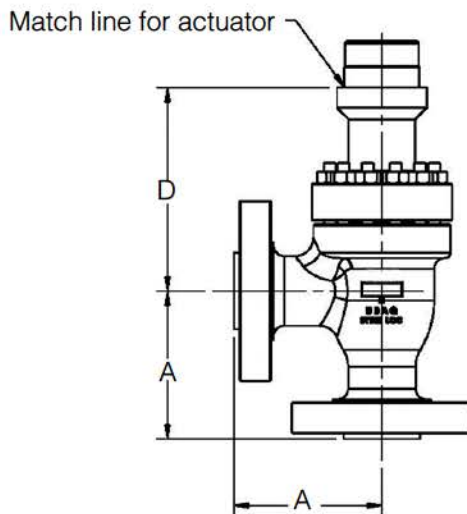

Mark DBAQ – Extension Bonnet

Approximate Shipping Weight for 2" 1500 lb RTJ less Actuator: 123 lb

MARK DBAQ SERIES ANGLE STYLE CONTROL VALVES

MARK DBAQ SERIES: PRODUCT BULLETIN

Flow Coefficients: M-Form Valve Plug

Flow Up- Equal Percent															
Body Size (in)	Port Diameter		Total Travel		Valve Opening- Percentage of Total Travel										F _L *
	in.	mm	in.	mm	10	20	30	40	50	60	70	80	90	100	
C_v															
2	1/4	6,4	3/4	19	0.103	0.137	0.184	0.243	0.321	0.440	0.628	0.875	1.21	1.59	0.97
	3/8	9,5	3/4	19	0.101	0.168	0.263	0.399	0.585	0.850	1.22	1.73	2.45	3.27	0.97
	1/2	12,7	3/4	19	0.193	0.380	0.561	0.794	1.12	1.58	2.23	3.16	4.33	5.55	0.97
	3/4	19,1	3/4	19	0.378	0.634	0.971	1.44	2.12	3.16	4.75	6.96	9.48	11.7	0.95
	1	25,4	3/4	19	0.684	1.08	1.66	2.52	3.80	5.72	8.52	12.5	16.1	19.2	0.92
	1-1/4	31,8	3/4	19	0.885	1.28	1.81	2.69	4.27	9.48	13.3	19.0	23.1	27.2	0.92
1 ^a			25 ^a	---	---	---	---	---	---	---	---	---	---	33.8	0.92
X_T															
2	1/4	6,4	3/4	19	0.482	0.417	0.420	0.479	0.522	0.563	0.548	0.565	0.591	0.643	---
	3/8	9,5	3/4	19	0.434	0.306	0.425	0.537	0.522	0.519	0.535	0.569	0.611	0.720	---
	1/2	12,7	3/4	19	0.792	0.754	0.687	0.665	0.635	0.618	0.600	0.600	0.663	0.748	---
	3/4	19,1	3/4	19	0.774	0.647	0.645	0.649	0.658	0.651	0.623	0.624	0.664	0.731	---
	1	25,4	3/4	19	0.647	0.645	0.659	0.644	0.623	0.612	0.614	0.621	0.721	0.784	---
	1-1/4	31,8	3/4	19	0.671	0.629	0.624	0.598	0.544	0.343	0.684	0.711	0.774	0.774	---
1 ^a			25 ^a	---	---	---	---	---	---	---	---	---	---	0.698	---
Flow Down- Equal Percent															
C_v															
2	1/2	12,7	3/4	19	0.452	0.832	1.28	1.85	2.46	3.19	4.38	6.33	7.05	9.04	0.55
	3/4	19,1	3/4	19	0.600	1.10	1.71	2.40	3.23	4.90	7.10	9.43	12.6	16.9	0.57
	1	25,4	3/4	19	1.19	2.00	2.92	4.15	5.83	8.05	10.7	14.5	19.0	24.1	0.64
	1-1/4	31,8	3/4	19	1.85	2.73	3.55	5.15	6.21	9.76	16.7	25.2	32.3	35.5	0.69
1 ^a			25 ^a	---	---	---	---	---	---	---	---	---	---	38.3	0.69
X_T															
2	1/2	12,7	3/4	19	0.210	0.162	0.123	0.125	0.134	0.157	0.168	0.159	0.254	0.267	---
	3/4	19,1	3/4	19	0.195	0.166	0.170	0.202	0.243	0.239	0.257	0.328	0.352	0.314	---
	1	25,4	3/4	19	0.158	0.139	0.152	0.190	0.218	0.256	0.312	0.370	0.413	0.412	---
	1-1/4	31,8	3/4	19	0.134	0.115	0.127	0.145	0.253	0.325	0.368	0.371	0.370	0.404	---
1 ^a			25 ^a	---	---	---	---	---	---	---	---	---	---	0.461	---

*At 100% travel

^aValve travel may be up to 1" (25mm) with slight sacrifice in flow characteristic.

Note: KV = (0,865) (CV)



Jordan Valve, a division of Richards Industries
 3170 Wasson Road • Cincinnati, OH 45209
 513.533.5600 • 800.543.7311 • 513.871.0105 (f)
 info@richardsind.com • www.jordanvalve.com