

TLV[®]

PowerTrap[®]

MODEL GP14L

SECONDARY PRESSURE DRAINER FOR PUMPING APPLICATIONS

Benefits

Pump for a wide range of applications. Ideal for medium flow condensate removal from vented receivers situated at a low level.

1. No cavitation or seal leakage.
2. Non-electric design with durable nickel-based alloy compression spring for reliable performance.
3. Pump will operate with a low filling head (min. 12").
4. Easy, inline access to internal parts simplifies cleaning and reduces maintenance costs.
5. Intake/exhaust valve heads are both Rockwell 65C with 45C seats for maximum durability.
6. High quality stainless steel internals ensure reliability.
7. Compact design permits installation in a limited space.
8. Float resists hydraulic shock to 1500 psig.
9. 2-year warranty for snap-action mechanism.*
10. Cycle Counter installable as option.

* Contact TLV for details



Specifications

Model		GP14L
Connection	Pumped Medium Inlet & Outlet	Flanged*
	Motive Medium & Pump Exhaust	Screwed
Size (in)	Pumped Medium: Inlet x Outlet	1½ x 1
	Motive Medium Inlet	½
	Pump Exhaust Outlet	½
Maximum Operating Pressure (psig)	PMO	200
Maximum Operating Temperature (°F)	TMO	428
Maximum Allowable Pressure (psig)	PMA	Cast Iron: 230 Cast Steel: 300
Maximum Allowable Temperature (°F)	TMA	Cast Iron: 428 Cast Steel: 500
Motive Medium Pressure Range (psig)		5 – 200
Maximum Allowable Back Pressure		7 psi less than motive medium pressure used
Volume of Each Discharge Cycle (gal)		Approx. 2
Motive Medium**		Saturated Steam, Compressed Air, Nitrogen
Pumped Medium***		Steam Condensate, Water

* For details of flange connection, see picture at bottom right.

** Do not use with toxic, flammable or otherwise hazardous fluids.

*** Do not use for fluids with specific gravities under 0.85 or over 1, or for toxic, flammable or otherwise hazardous fluids.

Connections and sizes in bold are standard



CAUTION

To avoid abnormal operation, accidents or serious injury, DO NOT use this product outside of the specification range. Local regulations may restrict the use of this product to below the conditions quoted.

No.	Description	Material	ASTM/AISI*	JIS	
①	Body	Cast Iron	A126 Cl.B	FC250	
		Cast Steel**	A216 Gr.WCB	—	
②	Cover	Cast Iron	A126 Cl.B	FC250	
		Cast Steel**	A216 Gr.WCB	—	
③	Cover Gasket	Graphite Compound	—	—	
④	Float	Stainless Steel	AISI316L	SUS316L	
⑤	Snap-action Unit	Stainless Steel	—	—	
⑥	Motive Medium Intake Valve Unit	Intake Valve	Stainless Steel	AISI440C	SUS440C
	Valve Seat	Stainless Steel	AISI420F	SUS420F	
⑦	Exhaust Valve Unit	Exhaust Valve	Stainless Steel	AISI440C	SUS440C
	Valve Seat	Stainless Steel	AISI420F	SUS420F	
⑧	Inlet Check Valve CKF5M	Stainless Steel	AISI304	SUS304	
⑨	Outlet Check Valve CKF3M	Cast Stainless Steel	A351 Gr.CF8	—	

* Equivalent ** Option: Cast Stainless Steel

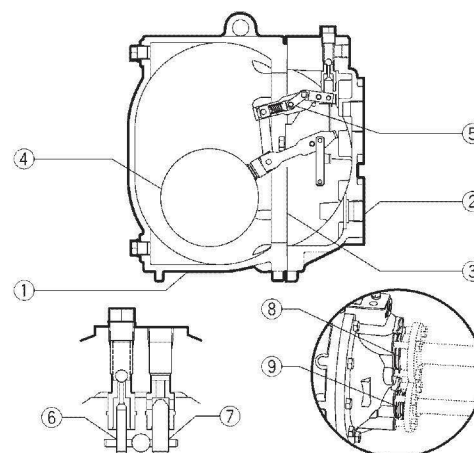

Copyright © TLV

Dimensions

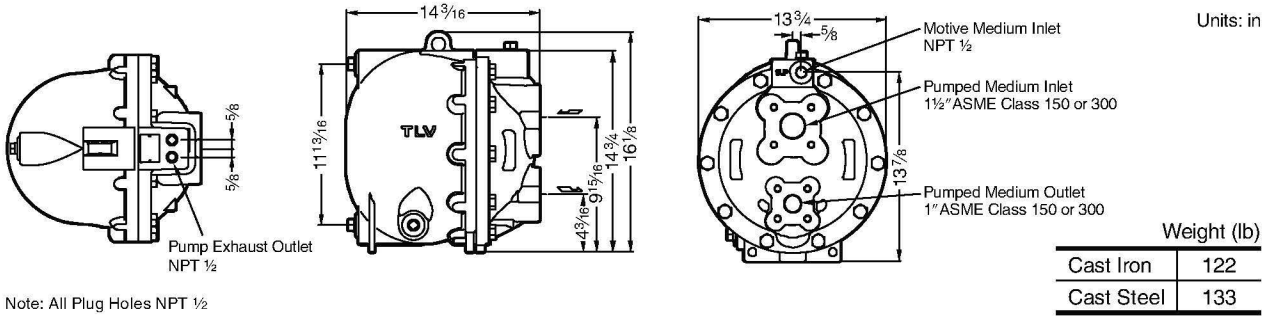

Discharge Capacity

Filling Head 25" from Grade

Inlet Pipe Size		1 1/2"		
Inlet Check Valve		1 1/2" CKF5M		
Outlet Check Valve		1" CKF3M		
Motive Medium		Air	Steam	
Motive Medium Inlet Pressure (Pm) (psig)	Total Lift or Back Press. (P2) psig	lb/h	lb/h	
200	25	4800	4410	
	40	4430	3550	
	60	4150	3090	
	80	3950	2380	
	100	3420	1850	
	150	2800	1120	
175	25	4650	4190	
	40	4370	3480	
	60	4010	2870	
	80	3820	2210	
	100	3330	1740	
	150	2670	930	
150	15	4850	4700	
	25	4590	4150	
	40	4300	3310	
	60	3770	2650	
	80	3550	1990	
	100	3090	1610	
125	15	4740	4540	
	25	4370	3790	
	40	3970	3040	
	60	3590	2320	
	80	3200	1720	
	100	2840	1270	
100	15	4590	4120	
	25	4190	3400	
	40	3770	2580	
	60	3400	1900	
	80	2910	1320	
	75	15	4370	3570
25		4060	2980	
40		3570	2010	
60		3150	1410	
50		10	4320	3750
		15	4190	3200
	25	3810	2400	
	40	3310	1480	
	25	5	4500	3750
		10	3900	3000
15		3660	2390	
10	2	4130	3110	

● **Correction Factor**

For GP14L installed with filling head other than 25" (minimum filling head: 12")

Filling Head from Grade	Inlet Pipe & Check Valve Size
	1 1/2" CKF5M
55"	1.10
43"	1.09
37"	1.07
31"	1.05
25"	1.00
22"	0.94
18"	0.82
12"	0.60

● **Illustration of Filling Head and Pressures**

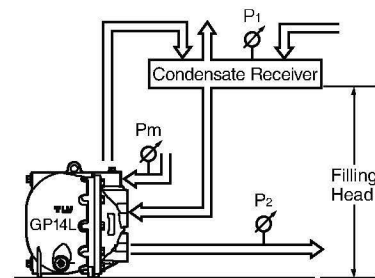

The discharge capacity is determined by the motive medium, motive medium pressure (Pm) and back pressure (P2).

Make sure that:
 Discharge Capacity × Correction Factor
 > Required Flow Rate

NOTE:

- A check valve must be installed at both the pumped medium inlet and outlet. To achieve the above capacities with the standard GP14L configuration, TLV check valves CKF5M for inlet and CKF3M for outlet must be used.
- Motive steam pressure minus back pressure must be greater than 7 psi.
- In closed system applications, the motive medium must be compatible with the liquid being pumped. If a non-condensable gas such as air or nitrogen is used as the motive medium, consult TLV for assistance.
- A strainer must be installed at the motive medium and pumped medium inlets.

Size of Receiver/Reservoir

The receiver/reservoir must have a capacity sufficient to store the condensate produced during the **PowerTrap** operation and discharge. A receiver will generally be larger than a reservoir because it must handle the condensate both as a liquid and as flash steam, and separate one from the other so that only condensate is sent to the **PowerTrap**.

If NO flash steam is present, use dimensions given in table ②. If flash steam is present, compare tables ① & ② and choose the larger resultant size. For all open systems, use table ① to select a suitable vent pipe diameter.

① Receiver Dimensions (Length: 3.5 ft)

Flash steam up to lb/h	Receiver diameter in	Vent pipe diameter in
50	3	1
75	4	1 ½
100	4	2
200	6	2 ½
300	8	3
400	8	4
600	10	4
800	12	6
1,000	14	6
1,400	16	8
1,600	18	8
2,000	20	8

② Reservoir Dimensions

Amount of Condensate (lb/h)	Reservoir Diameter (in) and Length (ft)						
	1 ½	2	3	4	6	8	10
500 or less	3.0 ft	2.0					
700	4.0	2.5	1.0				
1,000	5.5	3.5	1.5				
1,200		4.5	2.0	1.0			
1,500			2.5	1.5			
2,000			3.5	2.0			
3,000			4.5	3.0			
4,000			6.5	4.0	1.5		
5,000				5.0	2.5		
6,000				5.5	2.5	1.5	
7,000				6.5	3.0	1.5	
8,000					3.5	2.0	
9,000					4.0	2.5	1.5
10,000					4.5	2.5	1.5
12,000					5.0	3.0	2.0
14,000					6.0	3.5	2.5
16,000					6.5	4.0	2.5
18,000						4.5	3.0
20,000						5.0	3.5

Reservoir length can be reduced by 50% when the motive pressure (P_m) divided by back pressure (P₂) equals 2 or greater (when P_m ÷ P₂ ≥ 2).

Steam or Air Consumption (Motive Medium)

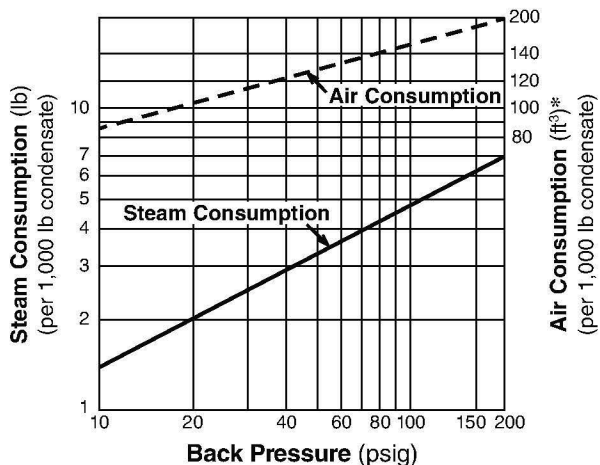

* Equivalent consumption of air at 68 °F under atmospheric pressure

Cycle Counter (option)

Two types of counter can be installed on the GP14L to monitor the number of pumping cycles and help to determine the timing of maintenance, or estimate the volume of pumped condensate.

- **C1CM – (Counter Unit Type):**
Self-contained standalone unit. Includes an LCD counter display and an operation indicator LED.
- **C1SM – (Terminal Box Type):**
Designed for use with remote monitoring equipment and systems.

Intrinsically safe models are also available.
See the Cycle Counter SDS for further details

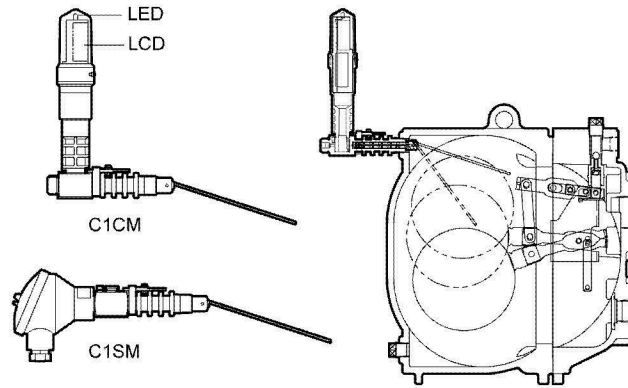

DO NOT DISASSEMBLE OR REMOVE THIS PRODUCT WHILE IT IS UNDER PRESSURE.
Allow internal pressure of this product to equal atmospheric pressure and its surface to cool to room temperature before disassembling or removing. Failure to do so could cause burns or other injury. READ INSTRUCTION MANUAL CAREFULLY.

TLV CORPORATION

13901 South Lakes Drive, Charlotte, NC 28273-6790
Phone: 704-597-9070 Fax: 704-583-1610
E-mail: tlv@tlvengineering.com
For Technical Service 1-800 "TLV TRAP"



Manufacturer
TLV CO., LTD.
Kakogawa, Japan
is approved by LRQA Ltd. to ISO 9001/14001

ISO 9001/ISO 14001

