

Mark 128 PQC Series

Control Valve

The Mark 128PQC Series Control Valve body assembly is suitable for on-off dump valve service in oil and gas production applications, in either sweet or sour gas conditions. This valve is also useful for on-off high-pressure control of numerous gasses and liquids, and can be used with materials that are viscous or erosive.

This is a single port valve with unbalanced stem-guided valve plug, and push-down-to-close valve plug action. Operated by a Type 128 spring-and-diaphragm actuator, the assembly can be operated in a normally open or normally closed application. This setting can be reversed in the field with minimum disruption and no additional parts.

The Mark 128PQC is a 1" Control Valve, standard configuration is with a solid pipe plug threaded into the bottom connection for straight-through flow. To convert the control valve to angle flow, the pipe plug can be installed in the left port as shown in Figure 1 in the I & M. Note: This configuration from straight-through flow to angle flow can be achieved in the field.

The Mark 128PQC Series valve is available with soft-seat, cageless soft seat, or all metal seat construction. All configurations have push-down-to-close valve plug action (Figure 2).

The valve plug shuts off against the integral seat ring in the cage, except in cageless soft-seat construction, where the shut-off is against the seat which is cut into the web of the valve body. Rotation of the valve plug is limited with the use of a nylon insert in the valve plug thread.

Any process leakage passing through the packing is permitted to escape through a leakoff vent which passes through the packing box and out the valve body. This prevents any leakage from passing along the stem into the actuator and also prevents loading pressure leakage from the lower diaphragm from reaching the valve body through the stem.



Mark 128PQC Control Valve

Warning:
The leakoff vent must be kept open at all times. Flammable or other hazardous fluids should be vented into an open, well-ventilated area to prevent fire or explosion.

FEATURES

- 1" screwed end connections
- Quick opening flow characteristic
- Can be converted from straight through flow to angle flow
- Field reversible multi-spring actuator
- Stem guided valve plug
- Sour service capability: optional NACE MR0 175/ ISO 15156-2009
- Tight shutoff

SPECIFICATIONS

Sizes: 1"

End Connections: NPT

Body Materials: WCB

Trim Materials: 316

Seats:

- Metal
- Soft-seat
- Cageless-soft seat

Shutoff: Class IV

Maximum Inlet Pressures and Temperatures:

- 3600 psi @ 100°F
- 3520 psi @ 180°F

Maximum Pressure Drops: See Table Below

Flow Characteristics: Quick Opening with a 45° taper plug

Flow Direction: Either Direction

Maximum Allowable Shutoff Pressure Drops

Seating	Actuator Action	Flowing Pressure Drop Tends To:	Port Diameter		Cadmium Coloured Main Spring 14A8831X012				Red Main Spring 14A9077X012			
			In	mm	@ 20 Psig (1.4 bar) Operating Signal Pressure (2 Springs Req'd)		@ 35 Psig (2.4 bar) Operating Signal Pressure (4 Springs Req'd)		@ 20 Psig (1.4 bar) Operating Signal Pressure (2 Springs Req'd)		@ 35 Psig (2.4 bar) Operating Signal Pressure (4 Springs Req'd)	
					Psi	Bar	Psi	Bar	Psi	Bar	Psi	Bar
Metal (All Types)	Fail Close	Open Valve	1/4	6,4	1510	104	3370	232	3880	233	3600	248
			3/8	9,5	520	36	1340	92	1340	92	3120	215
			1/2	12,7	220	15	690	47	700	48	1720	118
			3/4	19,1	30	2,1	240	16	240	16	710	49
		Close Valve	1/4	6,4	940	65	1860	128	1370	94	2920	201
			3/8	9,5	1130	78	2450	169	1540	106	3300	227
			1/2	12,7	1330	92	2920	201	1710	118	3600	248
			3/4	19,1	2030	140	3600	248	2320	160	3600	248
	Fail Open	Close Valve	1/4	6,4	170	12	350	24	---	---	---	---
			3/8	9,5	530	36	610	42	---	---	---	---
			1/2	12,7	540	37	1150	79	---	---	---	---
			3/4	19,1	1400	96	2910	200	---	---	---	---
Soft	Fail Close	Open Valve	1/4	6,4	1000	69	1000	69	1000	69	1000	69
			3/8	9,5	710	49	1000	69	1000	69	1000	69
			1/2	12,7	400	28	830	57	830	57	1000	69
			3/4**	19,1**	160	11	350	24	360	25	790	54
		Close Valve	1/4	6,4	940	65	1000	69	1000	69	1000	69
			3/8	9,5	1000	69	1000	69	1000	69	1000	69
			1/2	12,7	1000	69	1000	69	1000	69	1000	69
			3/4**	19,1**	1000	69	1000	69	1000	69	1000	69
	Fail Open	Close valve	1/4	6,4	560	39	660	45	---	---	---	---
			3/8	9,5	480	33	960	66	---	---	---	---
			1/2	12,7	540	37	1000	69	---	---	---	---
			3/4**	19,1**	1000	69	1000	69	---	---	---	---

* Contact Jordan Valve for pressure drop

** Available in 1" Mark 128 PQC valves as a cageless construction with the seat cut into the body

MARK 128PQC SERIES CONTROL VALVES

PRODUCT BULLETIN- MARK 128PQC

Flow Coefficients

Valve size	Port Diameter		Maximum Travel		Quick Opening													
					Valve Opening— Percent of Total Travel													
	mm	in	mm	in	10	30	70	100	10	30	70	100	10	30	70	100	100	
					Kv				Cv				Xt				FL	
Globe Valve- Flow Up																		
1	6,35	1/4	9,5	3/8	0,566	1,14	1,38	1,38	0,654	1,32	1,60	1,60	0,539	0,694	0,539	0,539	0,77	
	9,53	3/8	9,5	3/8	0,828	2,02	2,60	2,60	0,957	2,33	3,01	3,01	0,578	0,699	0,746	0,746	0,82	
	12,7	1/2	9,5	3/8	1,02	2,71	3,88	3,88	1,18	3,13	4,49	4,49	0,614	0,677	0,803	0,824	0,91	
	19,1	3/4	9,5	3/8	2,15	3,12	5,90	6,42	2,49	3,61	6,82	7,42	0,767	0,623	0,755	0,773	0,87	
Globe Valve—Flow Down																		
1	6,35	1/4	9,5	3/8	0,616	1,28	1,38	1,38	0,712	1,48	1,60	1,60	0,575	0,601	0,567	0,567	0,82	
	9,53	3/8	9,5	3/8	0,91	2,23	2,71	2,71	1,05	2,58	3,13	3,13	0,559	0,613	0,717	0,717	0,87	
	12,7	1/2	9,5	3/8	1,12	2,80	3,58	3,65	1,30	3,24	4,14	4,22	0,512	0,607	0,899	0,887	0,91	
	19,1	3/4	9,5	3/8	1,69	2,61	5,24	5,71	1,95	3,02	6,06	6,60	0,642	0,756	0,997	0,981	0,92	
Angle Valve—Flow Up																		
1	6,35	1/4	9,5	3/8	0,699	1,22	1,38	1,38	0,808	1,41	1,60	1,60	0,398	0,706	0,553	0,553	0,77	
	9,53	3/8	9,5	3/8	0,943	2,14	2,98	2,98	1,09	2,47	3,44	3,44	0,433	0,636	0,605	0,605	0,76	
	12,7	1/2	9,5	3/8	1,08	2,77	4,61	4,84	1,25	3,20	5,33	5,59	0,510	0,660	0,674	0,663	0,90	
	19,1	3/4	9,5	3/8	1,82	3,03	6,89	7,83	2,10	3,50	7,97	9,05	0,787	0,675	0,717	0,786	0,84	
Angle Valve—Flow Down																		
1	6,35	1/4	9,5	3/8	0,676	1,36	1,46	1,46	0,782	1,57	1,69	1,69	0,397	0,520	0,500	0,500	0,77	
	9,53	3/8	9,5	3/8	0,798	2,33	3,16	3,16	0,923	2,69	3,65	3,65	0,515	0,495	0,507	0,507	0,77	
	12,7	1/2	9,5	3/8	1,18	3,10	4,40	4,40	1,36	3,58	5,09	5,09	0,414	0,469	0,602	0,602	0,78	
	19,1	3/4	9,5	3/8	1,49	2,80	6,69	7,20	1,72	3,24	7,73	8,32	0,796	0,619	0,729	0,818	0,87	

DIMENSIONS - INCHES (MM)

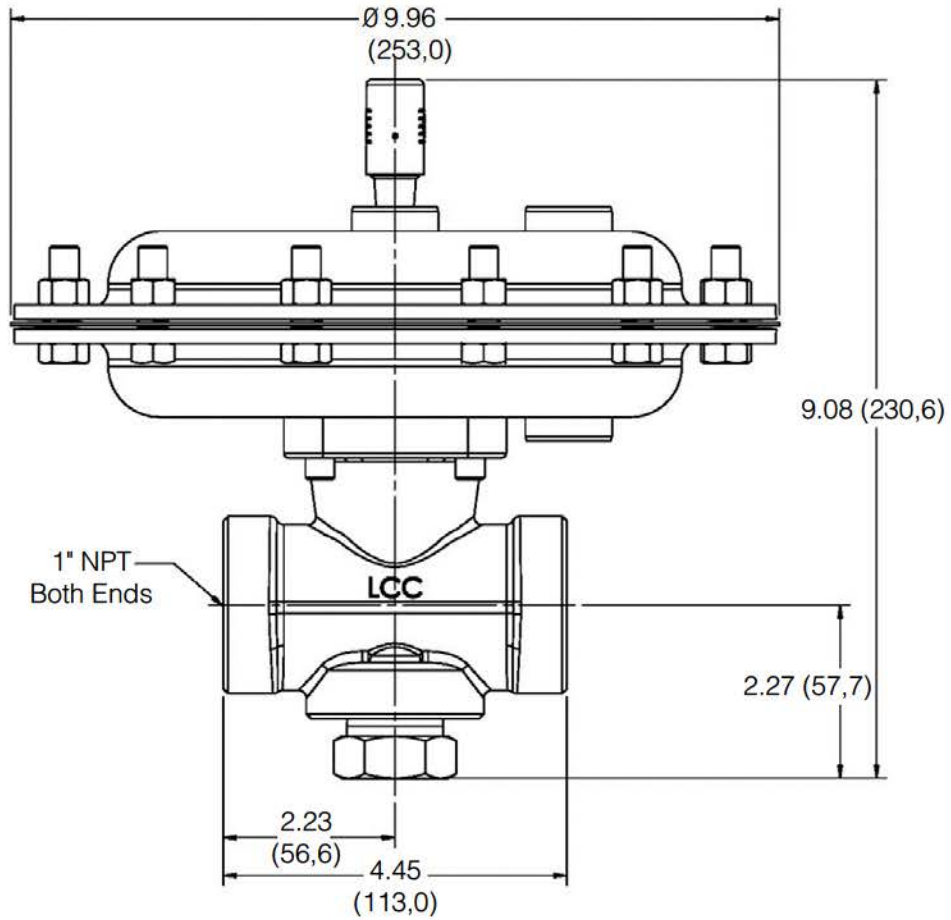

Approximate Weight: 17 lb (7.7 kg)