

Basic Features

LV Series

Features

- Used in systems for compliance with OSHA Standard 29 CFR Part 1910
- 3/8 inch to 1-1/4 inch Pipe Sizes
- Cv's from 6.0 to 14
- 3/4 and 1-1/4 inch Exhaust Ports available
- Rugged Cast Aluminum Alloy Body
- Inline or Surface Mountable
- Safety Yellow and Red for High Visibility
- Detented Spool
- Exhaust Port Threaded for Installation of Silencer or Line for Remote Exhausting

Applications

Lockout valves are installed in pneumatic drop legs, or individual pneumatic control lines (see Figure 1). In accordance with OSHA procedures, lockout valves are used during maintenance and service procedures of pneumatically (air) operated equipment. Prior to servicing, the red handle is pressed inward, blocking pressure and relieving all downstream air pressure. A padlock is installed through the locking hasp, Preventing accidental actuation during the maintenance procedure. Following maintenance, the padlock is removed and the red handle is pulled outward, returning air pressure to the system. (For complete Lockout / Tagout procedures, consult OSHA Standard 29 CFR Part 1910 in U.S. Federal Register/Vol. 54 No. 169, Friday, September 1, 1989 / Page 36644.)

Mounting

Valves can be inline mounted or surface mounted using the two 11/32" mounting holes provided in the valve body. Mount valves in plain view with the handle oriented for accessibility.



1-1/4" Exhaust Shown

Dimensions

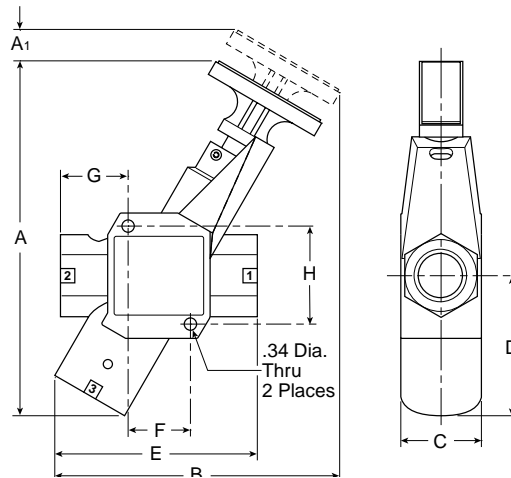

LV Series, 3/4" Exhaust Port Inches (mm)

A	A1	B	C	D
8.32 (211)	0.64 (16)	6.60 (168)	2.00 (51)	3.06 (78)
E	F	G	H	
4.24 (108)	1.32 (111)	1.56 (40)	2.21 (56)	

LV Series, 1-1/4" Exhaust Port Inches (mm)

A	A1	B	C	D
9.91 (252)	0.85 (22)	7.95 (202)	2.25 (57)	3.91 (99)
E	F	G	H	
5.65 (144)	1.74 (44)	1.89 (48)	2.74 (70)	

Operation

Normal Machine Operation – Valve Open
 With the handle pulled outward. Inlet Port 1 is open to outlet Port 2. Exhaust Port 3 is blocked.

Lockout Operation – Valve Closed
 With the handle pushed inward. Inlet Port 1 is blocked. Outlet Port 2 is open to Exhaust Port 3.

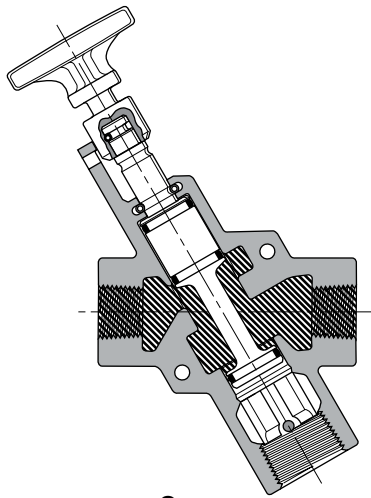

Open

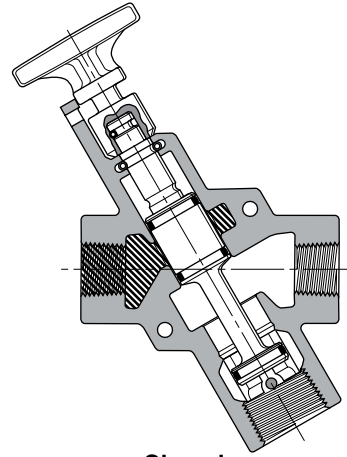

Closed

Specifications

Operating Pressure Range:
 15 to 300 PSIG (103 to 2068 kPa)

Operating Temperature Range (Ambient):
 40°F to 175°F (4°C to 80°C)

Lubrication:
 For best results and service life, use clean, moisture free, lubricated air.

Recommended Lubricant:
 F442 Oil

Materials of Construction

Body Cast Aluminum Alloy
Handle 3/8" - 1-1/4" Exhaust Port - Plastic
Spool Aluminum
Seals Carboxylated Nitrile
Detent Spring Stainless Steel
Grease Magnalube G[†]

[†] Trademark Magnalube

LV Series Model Number Index

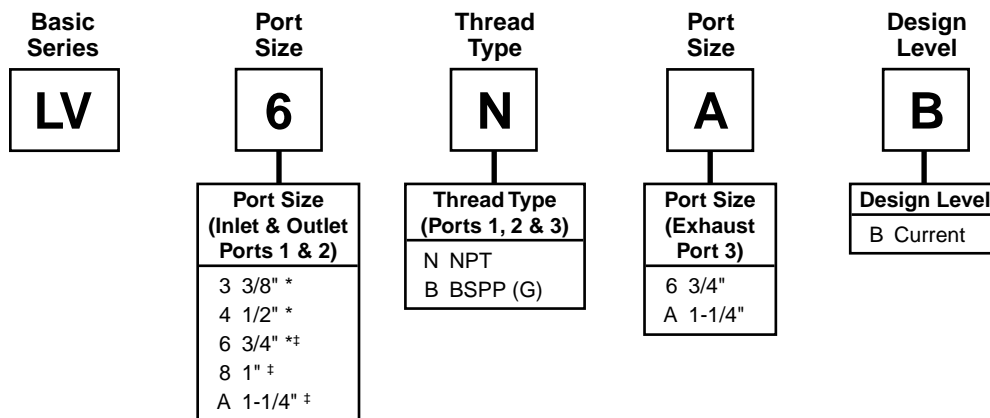

* Available with 3/4" Exhaust Port.

‡ Available with 1-1/4" Exhaust Port.



Basic Features

EZ Series

Features

- Combines Lockout and Soft-Start Functions in a Single Unit
- Used in systems for compliance with OSHA Standard 29 CFR Part 1910
- 3/8 inch to 1-1/4 inch Pipe Sizes
- Cv's from 3.7 to 13.7
- 3/4 and 1-1/4 inch: Exhaust Ports available
- Rugged Cast Aluminum Alloy Body
- Exhaust Port Threaded for Installation of Silencer or Line for Remote Exhausting
- Inline or Surface Mountable

Applications

EZ valves are installed in pneumatic drop legs, or individual pneumatic control lines (see Figure 1). In accordance with OSHA procedures, EZ valves are used during maintenance and service procedures of pneumatically (air) operated equipment. Prior to servicing, the blue handle is pressed inward, blocking pressure and relieving all downstream air pressure. A padlock is installed through the locking hasp, preventing accidental actuation during the maintenance procedure. Following maintenance, the padlock is removed and the blue handle is pulled outward, gradually returning air pressure to the system. (For complete Lockout / Tagout procedures, consult OSHA Standard 29 CFR Part 1910 in U.S. Federal Register/Vol. 54 No. 169, Friday, September 1, 1989 / Page 36644.)

Mounting

Valves can be inline mounted or surface mounted using the two 11/32" mounting holes provided in the valve body. Mount valves in plain view with the handle oriented for accessibility.

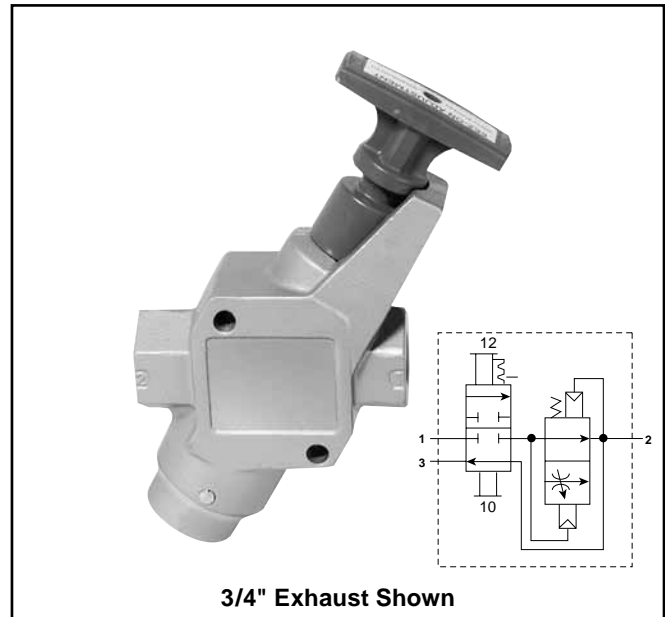

Dimensions

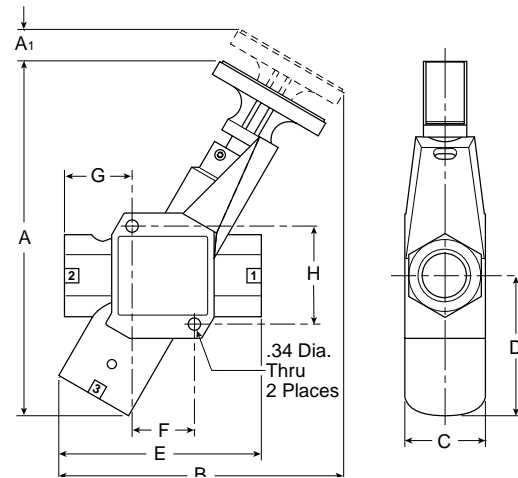

EZ Series, 3/4" Exhaust Port Inches (mm)

A	A1	B	C	D
8.32 (211)	0.64 (16)	6.60 (168)	2.00 (51)	3.06 (78)
E	F	G	H	
4.24 (108)	1.32 (111)	1.56 (40)	2.21 (56)	

EZ Series, 1-1/4" Exhaust Port Inches (mm)

A	A1	B	C	D
9.91 (252)	0.85 (22)	7.95 (202)	2.25 (57)	3.91 (99)
E	F	G	H	
5.65 (144)	1.74 (44)	1.89 (48)	2.74 (70)	

Operation

Normal Machine Operation – Valve Open

When the blue handle is pulled outward, the adjustable needle valve (accessed through the top of the handle) setting determines the rate of pressure buildup. When downstream pressure reaches the full flow described in the specifications below, Inlet Port 1 is open to outlet Port 2. Exhaust Port 3 is blocked.

Lockout Operation – Valve Closed

When the blue handle is pushed inward, the Inlet Port 1 is blocked. Downstream air is exhausted through Exhaust Port 3.

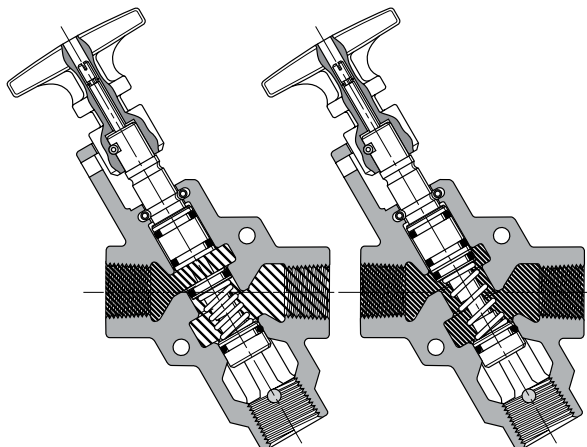

**Open
Pressure Building Up**

**Open
Full Flow**

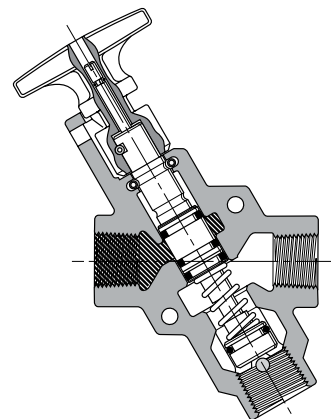

Closed

Specifications

Operating Pressure Range:

30 to 150 PSIG (2 to 10 bar)
Open to Full Flow: Inlet Pressure - 25 PSIG (1.7 bar)

Operating Temperature Range (Ambient):

40°F to 175°F (4°C to 80°C)

Lubrication:

For best results and service life, use clean, moisture free, lubricated air.

Recommended Lubricant:

F442 Oil

Materials of Construction

- Body** Cast Aluminum Alloy
- Handle** Plastic
- Spool** Aluminum
- Seals** Carboxylated Nitrile
- Detent Spring** Stainless Steel
- Grease** Magnalube G[†]

EZ Combination EEZ-On Series Model Number Index

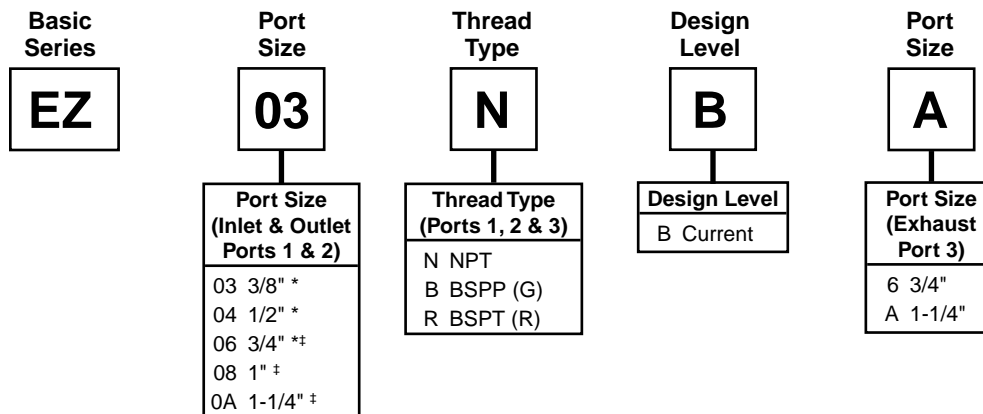

Notes:

* Available with 3/4" Exhaust Port.

† Available with 1-1/4" Exhaust Port.

† Trademark Magnalube

B

LV Series

EZ Series

Technical Information

Flow

Model	1 to 2 Cv	2 to 3 Cv
LV3N6B	6.00	8.00
LV4N6B	7.10	8.30
LV6N6B	8.60	9.50
LV6NAB	13.00	12.00
LV8NAB	13.00	14.00
LVANAB	20.00	14.00

Model	1 to 2 Cv	2 to 3 Cv
EZ03NB6	3.79	3.78
EZ04NB6	5.31	3.77
EZ06NBA	6.01	9.25
EZ08NBA	11.18	8.13
EZ0ANBA	13.74	8.03

B

LV Series

EZ Series

Schematic

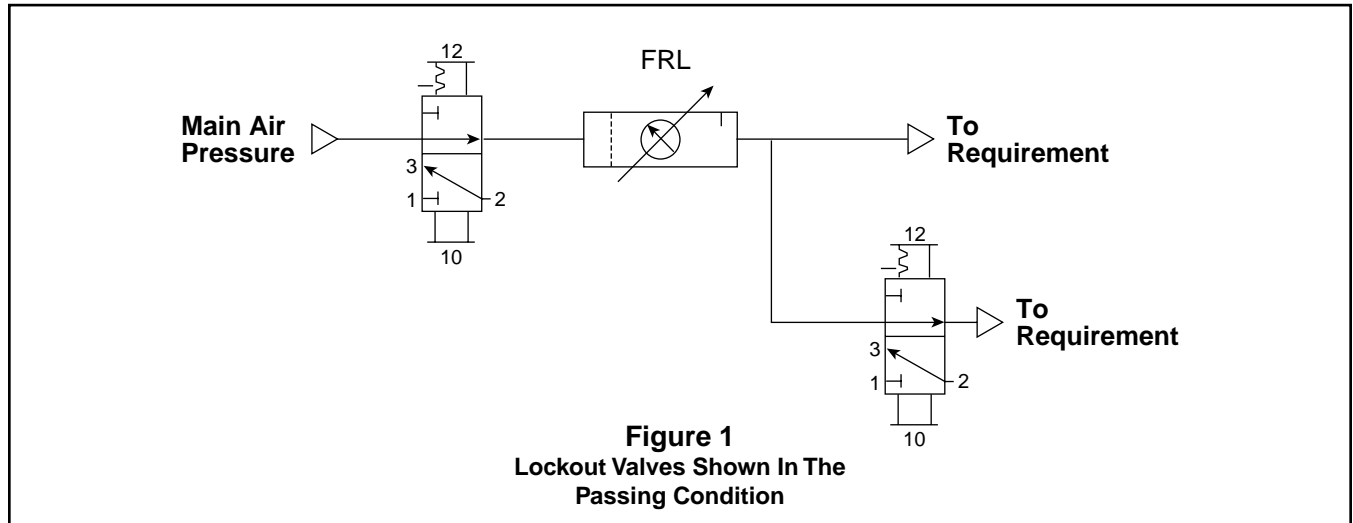

Friday, September 1, 1989 the Occupational Safety and Health Administration (OSHA) passed a standard, 29CFR Part 1910, requiring certain lockout and / or tagout procedures for the control of a hazardous energy source. This standard addresses practices and procedures that are necessary to disable the release of potentially hazardous energy while maintenance and servicing activities are being performed. Tagout refers to the use of tags to warn workers when equipment using potentially hazardous energy is being serviced. Lockout is the procedure which ensures that all power to a piece of equipment is isolated, locked or blocked and dissipated using a method that cannot be readily removed to bypassed. Dissipation means stored energy at the equipment is brought to a neutral state. This standard is expected to save 120 lives and prevent 60,000 accidents a year. This OSHA Standard became effective October 31, 1989.

A typical application (Figure 1) shows a main lockout valve mounted in the main drop leg, before the split to machine functions. Additional lockout valves can be used to isolate individual control lines. Before servicing, the valve can be actuated and locked to isolate downstream from pressure, and exhaust downstream to atmosphere thus making equipment safe for maintenance.

To reference this standard see the U.S. Federal Register / Vol. 54, No. 169 / Friday, September 1, 1989 / Page 36644. For copies of this standard, contact U.S. Department of Labor, Occupational Safety and Health Administration, Office of Publication, Room N3101, Washington, DC 20210, (202) 523-9667.