

Mark 66 Series

Air Loaded Pressure Regulators

The Mark 66 is a highly accurate and economical air loaded pressure regulator that provides regulation from a local station or from a remote station.

The operation of the Mark 66 requires no control spring or pilot. Instead, a static air signal is applied to the top of the diaphragm to determine the setpoint.

The Mark 66 has a rangeability of approximately 40:1; the same as our pilot-type sliding gate regulator, the Mark 67. Because of its lack of a pilot valve, the Mark 66 is not as susceptible to problems caused by dirty service.

The Mark 66 setpoint is adjusted by controlling the air pressure supplied to the top of the diaphragm. This supplied air pressure opens the valve to allow the process media to pass through the seats. The downstream pressure is sensed beneath the diaphragm. As the downstream pressure exceeds the setpoint, pressure is exerted on the diaphragm which raises the stem to modulate the seats toward the closed position.

Our JPR regulator (see Low Flow section) is ideal for controlling the pressure load to the top of the diaphragm.

FEATURES

- All metal-to-metal contacts – no gaskets or o-rings to wear out (2"/DN50 and under)
- Versatile application – use on steam, air, gas, liquids or chemicals
- Sliding Gate Seats – all of Jordan Valve's differential regulators feature advanced sliding gate seat technology
 - Straight-through flow for reduced turbulence and quiet operation
 - Short stroke for fast response and accurate regulation
 - Easily interchangeable Cv's
 - Tight Shutoff

CRN Registration Number Available



SPECIFICATIONS

Sizes: 1/2" through 6" (DN15 through DN150)

End Connections

- Threaded – FNPT, BSPT, BSPP
- ANSI Flanges – 150#, 300#
- DIN Flanges – PN10/16, PN25/40
- JIS Flanges – 10K, 20K

Body Materials

- Ductile Iron
- Bronze (1/2" to 2"/DN15 to DN50)
- Carbon Steel
- Stainless Steel
- Cast Iron (2-1/2" to 6" only/DN65 to DN150)

Trim Materials

- 303SS for DI, CI, BRZ & CS body valves
- 316 for SS body valves



Jordan Valve a division of Richards Industries
3170 Wasson Road • Cincinnati, OH 45209
513.533.5600 • 800.543.7311 • 513.871.0105 (f)
info@richardsind.com • www.jordanvalve.com

SPECIFICATIONS

Seat Materials

- Jorcote on SST – Standard
- Other materials available – Consult factory

Diaphragm Materials

- Stainless Steel - Standard (450°F (232°C) temp limit)
- Buna-Nitrile (200°F (93°C) temp limit)
- Viton (450°F (232°C) temp limit)
- Jorlon (450°F (232°C) temp limit)

Diaphragm Case

- DI (1/2" to 2" / DN15 to DN50)
- Steel (2-1/2" to 6" / DN65 to DN150)

Dome Loading Pressure: matches body pressure rating

Service: Steam, water, air, gas, oil, chemicals

Shutoff: ANSI Class IV

FEATURES

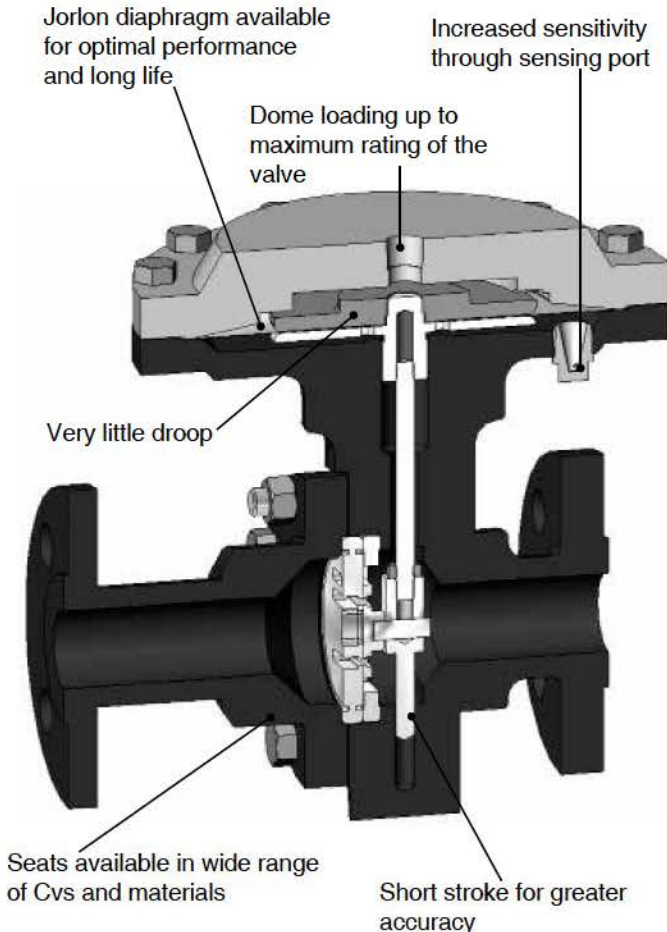

Cv (Kv) VALUES & MAXIMUM DIFFERENTIAL PRESSURES

Cv* (Kv)	Valve Size (DN)	Seat Material	Max ΔP, PSI (Bar)
2.5 (2,2)	1/2" & 3/4" (DN15 & DN20)	SST	125 (8,6)
		Jorcote	400 (27,6)
4.4 (3,8)	1/2" & 3/4" (DN15 & DN20)	SST	125 (8,6)
		Jorcote	400 (27,6)
6.4 (5,5)	1" & 1-1/4" DN25 & DN32	SST	125 (8,6)
		Jorcote	400 (27,6)
9.5 (8,2)	1" & 1-1/4" (DN25 & DN32)	SST	125 (8,6)
		Jorcote	400 (27,6)
15 (12,9)	1-1/2" (DN40)	SST	75 (5,2)
		Jorcote	325 (22,4)
25 (21,5)	2" (DN50)	SST	75 (5,2)
		Jorcote	325 (22,4)
30 (25,8)	2" (DN50)	SST	75 (5,2)
		Jorcote	325 (22,4)
55 (47,3)	2-1/2" (DN65)	Jorcote	150 (10,3)
115 (98,9)	3" (DN80)	Jorcote	150 (10,3)
200 (172)	4" (DN100)	Jorcote	150 (10,3)
395 (339,7)	6" (DN165)	Jorcote	150 (10,3)

* **Low Flow Cv's (Kv's) available:** reduced Cv's (Kv's) can be placed in any size valve as long as it is a smaller value than the standard Cv (Kv) for that particular size. In addition, the following special low flows can be provided:

1.6 (1,4)	0.84 (0,7)	0.42 (0,4)	0.21 (0,2)	0.08 (0,07)	0.04 (0,03)
0.02 (0,12)	0.008 (0,007)	0.004 (0,003)	0.002 (0,002)	0.0008 (N/A in 316SS) (0,0007)	

Body Rating

■ **1/2" – 2"**

- Ductile Iron* up to 600 psi (41,4 bar) @ 100°F (38°C) and 600 psi (41,4 bar) @ 650°F (343,3°C).
- Carbon Steel* and Stainless Steel* up to 950 psi (65,5 bar) @ 100°F (38°C) and 890 psi (61,4 bar) @ 650°F (343,3°C).
- Bronze* up to 500 psi (34,5 bar) @ 100°F (38°C) and 325 psi (22,4 bar) @ 500°F (260°C)
- Temperature limit of -20°F (-28,9°C) on all materials; for other temperatures consult factory

* *Note: Double bolting is required to reach these pressures. Consult factory for details.*

■ **2-1/2" – 6"**

- Ductile Iron up to 500 psi (34,4 bar) @ 100°F (38°C) and 450 psi (31,0 bar) @ 650°F (343,3°C).
- Carbon Steel up to 500 psi (34,4 bar) @ 100°F (38°C) and 500 psi (34,5 bar) @ 650°F (343,3°C)
- Stainless Steel up to 500 psi (34,4 bar) @ 100°F (38°C) and 445 psi (30,7 bar) @ 650°F (343,3°C)
- Cast Iron up to 500 psi (34,4 bar) @ 100°F (38°C) and 250 psi (17,2 bar) @ 450°F (232,2°C)

MARK 66 SERIES AIR LOADED PRESSURE REGULATOR

DIMENSIONS

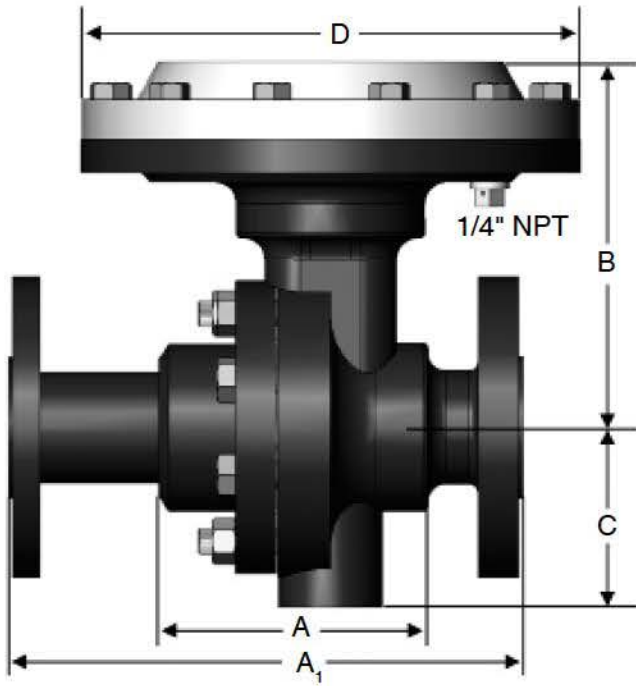

FLANGED ENDS, DIN

Valve Size (DN)	Flange (PN)	Dimensions (mm)						Weight Kgs	
		A		B		C	D	DI/BRZ	CS/SS
		DI/BRZ	CS/SS	DI/BRZ	CS/SS	ALL	ALL		
15	10/16	244	244	104	102	43	181	8,2	9,5
	25/40	244	260	104	102	43	181	9,1	10,4
20	10/16	244	244	104	102	43	181	9,1	10,4
	25/40	244	260	104	102	43	181	10,0	11,3
25	10/16	184	160	109	117	67	181	10,0	12,2
	25/40	184	160	109	117	67	181	10,9	13,2
32	10/16	200	—	109	—	67	181	10,0	—
	25/40	200	—	109	—	67	181	11,8	—
40	10/16	222	200	108	123	59	181	11,8	13,6
	25/40	222	200	108	123	59	181	14,5	16,3
50	10/16	254	230	114	122	70	181	14,5	16,3
	25/40	254	230	114	122	70	181	16,3	18,1

Larger Sizes (Only for DI/CS/SS)

Valve Size	ANSI Flange	Dimensions (mm)				Weight Kgs		
		A		B	C	D	DI/BRZ	CS/SS
		DI/BRZ	CS/SS	ALL	ALL			
65	10/16	283	—	271	176	324	73	—
	25/40	283	—	271	176	324	73	—
80	10/16	312	—	271	176	324	82	—
	25/40	312	—	271	176	324	82	—
100	10/16	350	—	302	203	324	95	—
	25/40	350	—	302	203	324	95	—
150	10/16	471	—	320	229	324	136	—
	25/40	471	—	320	229	324	136	—

FLANGED ENDS

Valve Size	ANSI Flange	Dimensions (inches)						Weight Lbs	
		A		B		C	D	DI/BRZ	CS/SS
		DI/BRZ	CS/SS	DI/BRZ	CS/SS	ALL	ALL		
1/2"	150#	9.62	9.62	4.11	4.03	1.69	7.12	18	21
	300#	9.62	10.25	4.11	4.03	1.69	7.12	20	23
3/4"	150#	9.62	9.62	4.11	4.03	1.69	7.12	20	23
	300#	9.62	10.25	4.11	4.03	1.69	7.12	22	25
1"	150#	7.25	7.25	4.31	4.60	2.62	7.12	22	27
	300#	8.75	7.75	4.31	4.60	2.62	7.12	24	29
1-1/4"	150#	7.87	—	4.31	—	2.22	7.12	22	—
	300#	8.37	—	4.31	—	2.22	7.12	26	—
1-1/2"	150#	8.75	8.75	4.27	4.85	2.31	7.12	26	30
	300#	10.25	9.25	4.27	4.85	2.31	7.12	32	36
2"	150#	10.00	10.00	4.49	4.82	2.75	7.12	32	36
	300#	10.50	10.50	4.49	4.82	2.75	7.12	36	40

Larger Sizes (Only for DI/CS/SS)

Valve Size	ANSI Flange	Dimensions (inches)				Weight Lbs		
		A		B	C	D	DI/BRZ	CS/SS
		DI/BRZ	CS/SS	ALL	ALL			
2-1/2"	125-150	10.87	—	10.68	6.93	12.75	160	—
	250-300	11.50	—	10.68	6.93	12.75	160	—
3"	125-150	11.75	—	10.68	6.93	12.75	180	—
	250-300	12.50	—	10.68	6.93	12.75	180	—
4"	125-150	13.87	—	11.88	8.00	12.75	210	—
	250-300	14.50	—	11.88	8.00	12.75	210	—
6"	125-150	17.75	—	12.57	9.00	12.75	300	—
	250-300	18.62	—	12.57	9.00	12.75	300	—

THREADED ENDS

Valve Size	Material	Dimensions (inches)				Weight Lbs
		A	B	C	D	
1/2" & 3/4"	DI/BRZ	3.62	4.11	1.69	7.12	16
	CS/SS	3.62	4.03	1.69	7.12	19
1"	DI/BRZ	4.12	4.31	2.62	7.12	18
	CS/SS	4.18	4.60	2.62	7.12	23
1-1/4"	DI/BRZ	4.12	4.31	2.62	7.12	18
1-1/2"	DI/BRZ	4.50	4.27	2.31	7.12	20
	CS/SS	4.81	4.85	2.25	7.12	24
2"	DI/BRZ	4.50	4.49	2.75	7.12	22
	CS/SS	5.50	4.82	2.75	7.12	26

THREADED ENDS, DIN

Valve Size (DN)	Material	Dimensions (mm)				Weight Kgs
		A	B	C	D	
15 & 20	DI/BRZ	92	104	43	181	7,3
	CS/SS	92	104	43	181	8,6
25	DI/BRZ	105	109	67	181	8,2
	CS/SS	106	117	67	181	10,4
32	DI/BRZ	105	109	67	181	8,2
40	DI/BRZ	114	108	59	181	9,1
	CS/SS	122	123	59	181	10,9
50	DI/BRZ	114	114	70	181	10,0
	CS/SS	140	122	70	181	11,8

MARK 66 SERIES AIR LOADED PRESSURE REGULATOR

ORDERING SCHEMATIC

Model No	Size	Body Mat'l	/	1	2	3	4	5	6	7	8	9	10	11	12	13	14	15

	Model
66	Standard

	Size
050	1/2" (DN15)
075	3/4" (DN20)
100	1" (DN25)
125	1-1/4" (DN32)
150	1-1/2" (DN40)
200	2" (DN50)
250	2-1/2" (DN65)
300	3" (DN80)
400	4" (DN100)
600	6" (DN150)

	Body Material
DI	Ductile Iron
BR	Bronze
CS	Carbon Steel (WCB)
S6	Stainless Steel (CF8M)
CI	Cast Iron

1 & 2	End Connections
PT	NPT
BT	BSPT
BP	BSPP
SW	FSW
I1	125# IFE
F1	125# FE (Except IFE)
I5	150# IFE
F5	150# FE (Except IFE)
I2	250# IFE
F2	250# FE (Except IFE)
I3	300# IFE
F3	300# FE (Except IFE)
ZZ	Non-Standard

3 & 4	Trim
S3	303SS
S6	316SS
I3	303SS F/IFE
I6	316SS F/IFE
ZZ	Non-Standard

5	Seats
A	303SST
B	316SST
V	303SS/Jorcote
W	316SS/Jorcote

6	Cv's (Kv's)				
	Cv	Kv		Cv	Kv
1	0.21	0,18	A	25	21,5
2	0.42	0,36	B	30	25,8
3	0.84	0,72	D	55	47,4
4	1.6	1,4	F	85	73,3
5	2.5	2,2	G	115	99,1
6	4.4	3,8	H	130	112
7	6.4	5,5	I	200	172
8	9.5	8,2	J	395	341
9	15	12,9			

7 & 8	Range
00	None

9 & 10	Diaphragm
S6	316SST
VI	Viton
BN	Buna-N
JL	Jorlon
ZZ	Non-Standard

11 & 12	Actuator
MD	For Metal Diaphragm
ED	For Elastomer Diaphragm
ZZ	Non-Standard

13 & 14	Double Bolting
00	None
ZZ	Double Bolting

15	Accessories
0	None
6	316SS Bolting
8	High Temperature Bolting
Z	Non-Standard

