

# Mark 75 Series

CRN Registration Number Available

## Wafer Style Control Valves

The Mark 75 wafer style control valve was developed by Jordan Valve as the next generation of control valves. Featuring all the benefits of the time-tested Sliding Gate design, in a lightweight, compact wafer-style body, the Mark 75 dramatically reduces the size and weight of conventional control valves.

The Mark 75 offers a variety of design features that help provide the superior performance customers expect from Jordan Valve.

### PRICING ADVANTAGE

The Mark 75 offers an incredible pricing advantage in the market place due to its wafer style body. A 6" Mark 75 valve is only 2.23" (56,6 mm) face-to-face in comparison to a 6" Mark 707/711 that is 17.75" (451 mm) face-to-face.

What does this mean to you? You pay for less metal to make the valve. In the case above, 15.50" (394 mm) of metal! The actual material is only part of the savings. You pay less for machining time; even shipping costs are reduced due to the lighter weight.

### WEIGHT ADVANTAGE

The weight advantage also allows you to spend less money and time on installation and support. With a 6" Mark 75 weighing less than 80 lbs (36,3 kgs), there is no need to rent a lift to put the valve in line as you would have with heavier alternative valves. Supporting the lighter weight Mark 75 is much simpler and less costly than a standard globe style valve.

With Jordan Valve's time-tested sliding gate seats at the heart of the Mark 75, the stroke remains much smaller than typical globe style valves. The shorter stroke means smaller actuators are needed to operate the valve, increasing the accuracy of the Mark 75 while reducing the overall weight and air consumption.



### CAPACITY

The Mark 75 provides great capacity in a compact wafer style body. A 2" Mark 75 provides 72 Cv (62 Kv), a 6" Mark 75 provides 400 Cv (345 Kv) and an 8" Mark 75 provides 600 Cv (522 Kv) as the linear operating Cv. (Refer to Cv Capacity Charts for information concerning all line sizes).

### EASE OF MAINTENANCE

The Mark 75 features a 'T' slot design connection to the disc. This connection allows for quick and easy reversing of functions. Instead of having to go into the actuator to change action, all that is needed in a Mark 75 is to turn the seats 180°. With this simple rotation, the valve can go from reverse acting to direct acting (or vice versa).

The stroke length of the Mark 75 is a slightly longer stroke than standard sliding gate valves. This longer stroke enables better turndown. Combined with the capacity of the Mark 75, the increased turndown makes for a great control valve.



**SPECIFICATIONS**

**Sizes:** 1" (DN25) through 8" (DN200)

1" (DN25) thru 6" (DN150) ANSI 150# / 300# (PN25/40) Class Wafer Style Valves (bolt-around); 8" (DN200) ANSI 150# (PN25) Class Wafer Style Valves (bolt-thru)

**Body/Bonnet Connection**

- 316 Stainless Steel (ASME SA-479)
- Carbon Steel (SA-105)

**Trim Material**

- 303 Stainless Steel (8" only)
- 316 Stainless Steel

**Seats Materials**

- Jorcote/316SS – standard
- Jorcote with 303SS - optional

**Yoke Materials**

- Ductile Iron (1" - 2")
- NAMUR Cast Iron

**Actuator Case Material:** Epoxy coated steel

**Packing Material**

- Spring loaded Teflon V-Ring to 500°F (260°C)
- Grafoil above 500°F (260°C)

**Shutoff:** ANSI Class IV tightness

**Ranges:** 3-15, 3-9\*, 9-15\*, 6-30 psi (0,2–1,0; 0,2–0,6; 0,6–1,0; 0,4–2,1 bar)

\* positioner required

**Action**

- Direct (ATC)
- Reverse (ATO)

**Body Rating (1" – 6")**

- Stainless Steel 720 psi @ 100°F (49,6 bar @ 37,8°C); 480 psi @ 500°F with Teflon packing (33,1 bar @ 260°C); 445 psi @ 550°F with braided packing (30,7 bar @ 288°C)
- Carbon Steel 740 psi @ 100°F (51,0 bar at 38°C); 600 psi @ 500°F with Teflon packing (41,4 bar @ 260°C); 535 psi @ 550°F with braided packing (39,6 bar @ 343°C)

**Body Rating (8")**

- Stainless Steel 275 psi @ 100°F (19 bar @ 38,8°C) and 155 psi @ 550°F (10,7 bar @ 288°C)
- Carbon Steel 285 psi @ 100°F (19,7 bar @ 38,8°C) and 155 psi @ 550°F (10,7 bar @ 288°C)

**Actuators**

- 35M, 55M, 85M, 100M multi-spring actuator (depending on size/pressure drop)
- Direct mount pneumatic piston
- Electric motorized

**Turndown Ratio Capability:** 100:1

**PRESSURE/TEMPERATURE CHART**

**Carbon Steel**

**Stainless Steel**

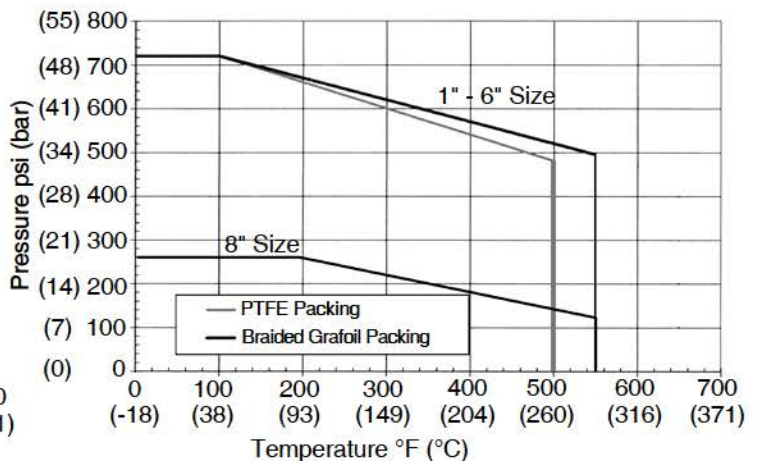
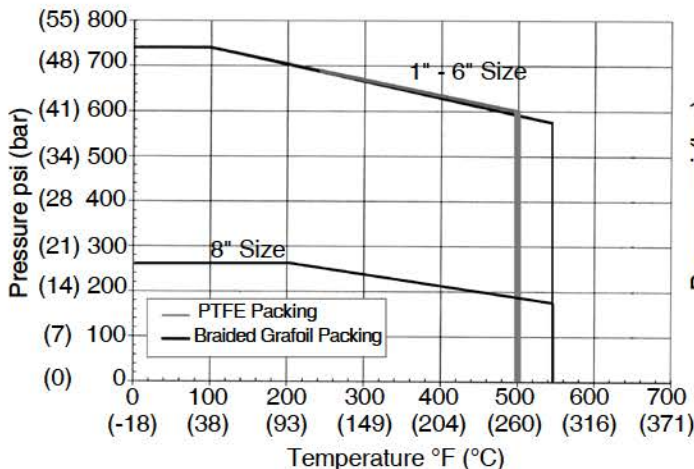

## MARK 75 SERIES WAFER STYLE CONTROL VALVES

### Cv/Kv vs TRAVEL – LINEAR

Cv (Kv)	Flow Characteristics	10%	20%	30%	40%	50%	60%	70%	80%	90%	100%
9.5 (8,2)	Linear	0.95	1.90	2.85	3.8	4.75	5.70	6.65	7.60	8.55	9.5
33 (28)	Linear	3.3	6.6	9.9	13.2	16.5	19.8	23.1	26.4	29.7	33
38 (33)	Linear	3.8	7.6	11.4	15.2	19.0	22.8	26.6	30.4	34.2	38
72 (62)	Linear	7.2	14.4	21.6	28.8	36.0	43.2	50.4	57.6	64.8	72
76 (66)	Linear	7.6	15.2	22.8	30.4	38.0	45.6	53.2	60.8	68.4	76
103 (89)	Linear	10.3	20.6	30.9	41.2	51.5	61.8	72.1	82.4	92.7	103
180 (155)	Linear	18	36	54	72	90	108	126	144	162	180
400 (345)	Linear	40	80	120	160	200	240	280	320	360	400
600 (510)	Linear	60	120	180	240	300	360	420	480	540	600

Cv vs Travel curves represent projected performance based on file data. Actual results may vary from system to system.

### Cv (Kv) VALUES

Size	DN	Linear Cv	Linear Kv	Equal Percentage Cv	Equal Percentage Kv
1"	DN25	9.5	8,2	CF	CF
1-1/2"	DN40	33	28	CF	CF
2"	DN50	38	33	CF	CF
		72	62	CF	CF
2-1/2"	DN65	76	66	CF	CF
3"	DN80	103	89	CF	CF
4"	DN100	180	155	CF	CF
6"	DN150	400	345	CF	CF
8"	DN200	600	510	CF	CF

CF = Consult Factory for Equal Percentage Requirements

Note: EQP trim available to full linear Cv if programmed through MK16IQ positioner

### MAXIMUM Δ Ratings, PSI (BAR) Without Positioner

Size	Actuator	Teflon	Jorcote
1"	35M	125 (8,6)	150 (10,3)
1-1/2" – 2"	35M	125 (8,6)	125 (8,6)
1"	55M	200 (13,8)	225 (15,5)
1-1/2" – 2"	55M	175 (12,1)	175 (12,1)
1-1/2" – 2"	85M	250 (17,2)	275 (19,0)
2-1/2" – 3"	55M	40 (2,8)	50 (3,4)
4"	55M	25 (1,7)	35 (2,4)
6"	55M	25 (1,7)	35 (2,4)
2-1/2" – 3"	85M	75 (5,2)	80 (5,5)
4"	85M	40 (2,8)	50 (3,4)
6"	85M	40 (2,8)	50 (3,4)

**MAXIMUM  $\Delta$  Ratings, PSI (BAR) With Positioner**

Size	Actuator	Teflon	Jorcote
1" – 2"	35M	175 (12,1)	200 (13,8)
2-1/2"	35M	150 (10,3)	185 (12,8)
1" – 2"	55M	275 (19,0)	300 (20,7)
2-1/2" – 3"	55M	250 (17,2)	275 (19,0)
4"	55M	200 (13,8)	225 (15,5)
6"	55M	125 (8,6)	150 (10,3)
1"	85M	475 (32,8)	500 (34,5)
1-1/2" – 2"	85M	425 (29,3)	450 (31,0)
2-1/2" – 3"	85M	325 (22,4)	400 (27,6)
4"	85M	300 (20,7)	325 (22,4)
6"	85M	200 (13,8)	225 (15,5)
8"	100M	220 (15,2)	250 (17,2)
2-1/2" – 3"	55M	250 (17,2)	275 (19,0)
4"	55M	200 (13,8)	225 (15,5)
6"	55M	125 (8,6)	150 (10,3)
2-1/2" – 3"	85M	375 (25,9)	400 (27,6)
4"	85M	300 (20,7)	325 (22,4)
6"	85M	200 (13,8)	225 (15,5)
8"	100M	220 (15,2)	250 (17,2)

Note: 45 psi (3,1 bar) for ATO & ATC (35 min, 45 max)

**SLIDING GATE FEATURES & BENEFITS**

*Jordan Valve's Sliding Gate Seats*

Installed in the widest range of gas, chemical and steam applications the world over, our pressure regulators, temperature regulators and control valves have been providing the following benefits for over fifty years.

**Shorter stroke length than globe or cage designs**

- Provides faster response to input signal changes
- Significantly extends packing and diaphragm life
- Allows for more compact valve/actuator assembly

**Straight-through flow**

- Significantly reduces turbulence, thereby reducing noise and erosion
- Markedly increases rangeability associated with "flow to open" and "flow to close" designs
- Eliminate valve "chatter" commonly observed when valve is partially open

**Ease of maintenance**

- During seat/Cv change (seats are not screwed or pressed in body)
- Attributable to lightweight, compact design
- Fewer trim components

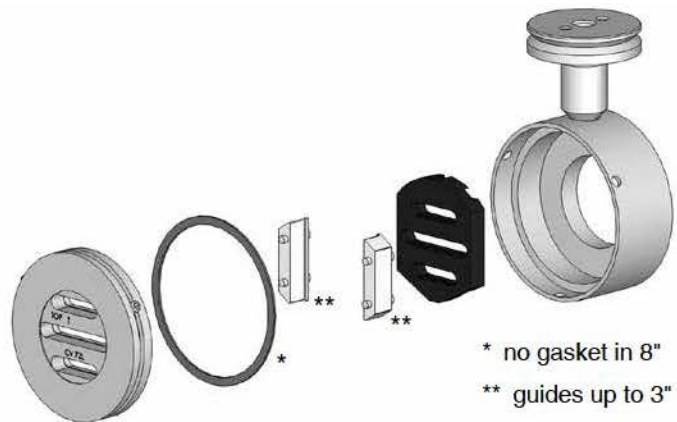

**Features**

- Easy installation between flanges with wafer body
- High flow rates
- Self cleaning, self lapping seats
- Reduced noise compared to conventional globe/cage valves
- More resistant to cavitation / flashing with straight through, wafer design

**8" MARK 75 WITH 100M ACTUATOR & MK16IQ POSITIONER**

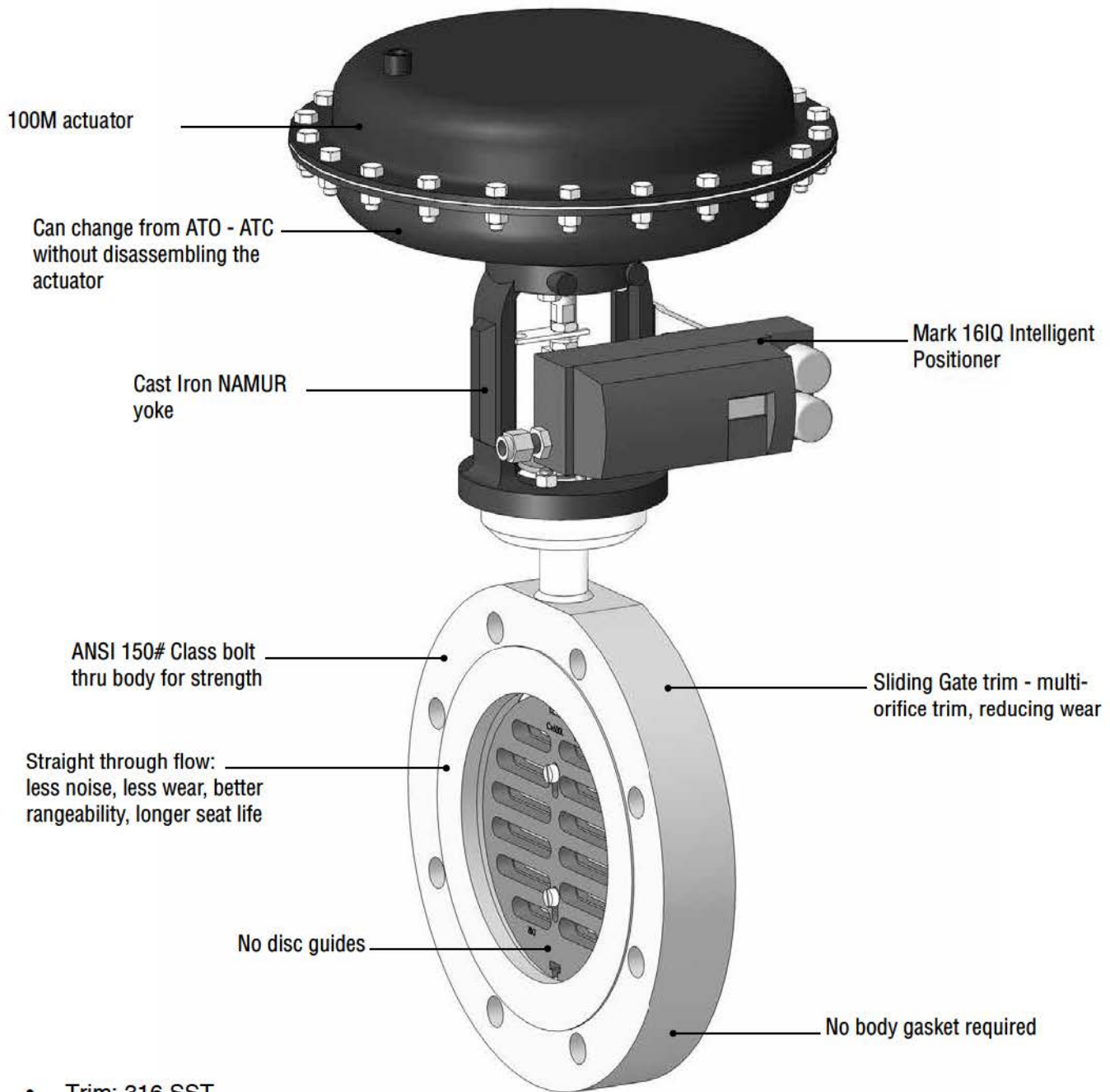

- Trim: 316 SST
- Seat Materials: Jorcote with 316SS
  - no body gasket
- Actuator Case: 100M steel
- Packing Materials: spring loaded Teflon V-ring, grafoil above 500°F (260°C)
- Ratings:
  - Stainless Steel 275 psi @ 100°F (19 bar @ 38,8°C) and 155 psi @ 550°F (10,7 bar @ 288°C)
  - Carbon Steel 285 psi @ 100°F (19,7 bar @ 38,8°C) and 155 psi @ 550°F (10,7 bar @ 288°C)
- Flow Capacity: 600 Cv (522 Kv) Linear and Equal Percentage (determined by positioner)
- Maximum Pressure Drop: 250 psi (17,2 bar) with 100M actuator, 12-25 psi (0,83-1,7 bar) bench set with side mounted positioner

1" THRU 3" MARK 75 SERIES WITH CAST BODY

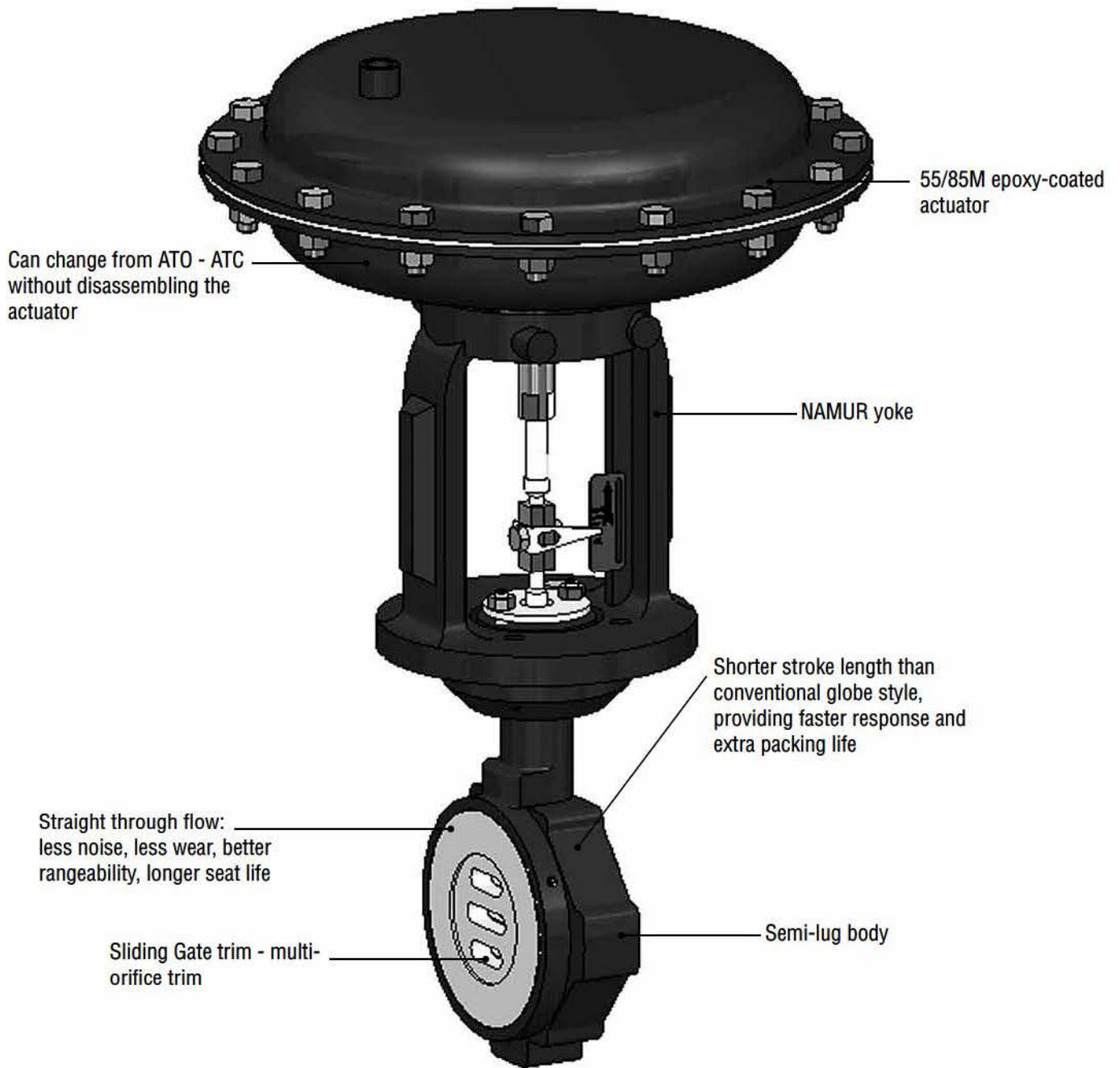

4" THRU 6" MARK 75 SERIES WITH BAR STOCK BODY

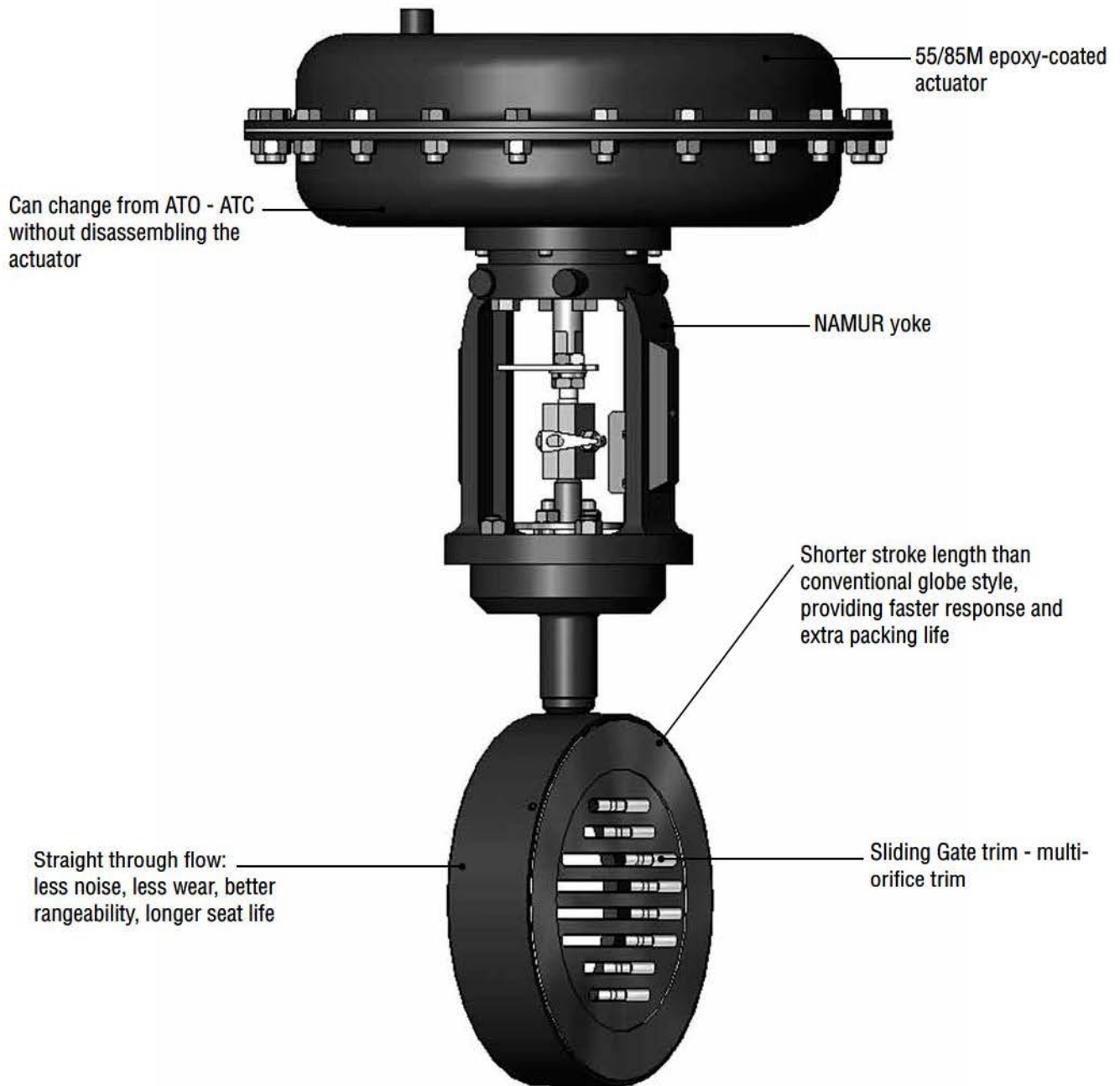

**DIMENSIONS – MK75 WITH MV1010 MOTOR**

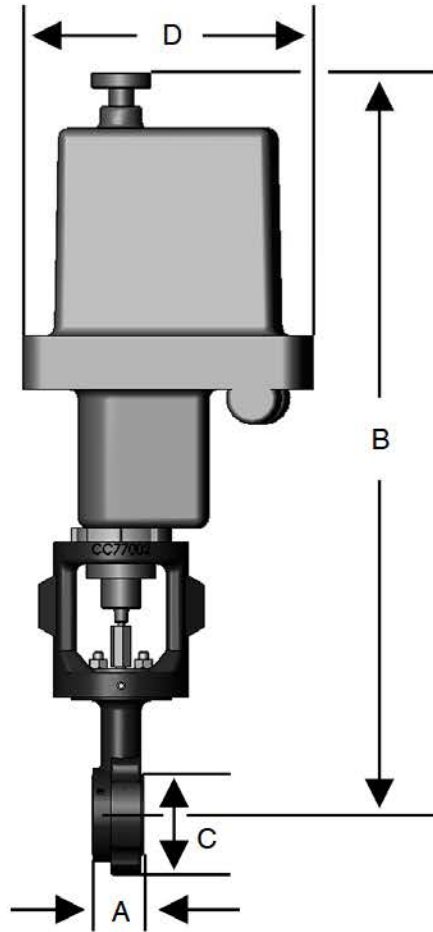

**INCHES**

Valve Size	Motor Size	Dimensions				Weight Lbs
		A	B	C	D	
1"	MV1010	1.24	18.58	2.76	7.13	20
1-1/2"	MV1010	1.36	19.09	3.24	7.13	22
2"	MV1010	1.76	19.44	3.98	7.13	22

**METRIC**

Valve Size	Motor Size	Dimensions, mm				Weight Kgs
		A	B	C	D	
DN25	MV1010	31,5	472	70,1	181	9,1
DN40	MV1010	34,5	485	82,3	181	10,0
DN50	MV1010	44,7	494	102	181	10,0

Valve Size	Motor Size	Dimensions				Weight Lbs
		A	B	C	D	
2-1/2"	MV1010	1.81	21.93	4.36	7.13	32
	VA1020		27.17			40
3"	MV1010	1.81	23.18	5.25	7.13	44
	VA1020		28.42			52
4"	MV1020	2.06	24.23	6.46	7.13	53
	VA1010		29.47			61
6"	VA1010	2.23	—	8.62	7.13	69
	VA1020		30.76			77

Valve Size	Motor Size	Dimensions, mm				Weight Kgs
		A	B	C	D	
DN65	MV1010	46,0	557	111	181	14,5
	VA1010		690			18,1
DN80	MV1010	46,0	589	133	181	20,0
	VA1010		722			23,6
DN100	MV1020	52,3	615	164	181	24,0
	VA1010		749			27,7
DN150	VA1010	56,6	—	219	181	31,3
	VA1020		781			34,9



**DIMENSIONS – MK75**

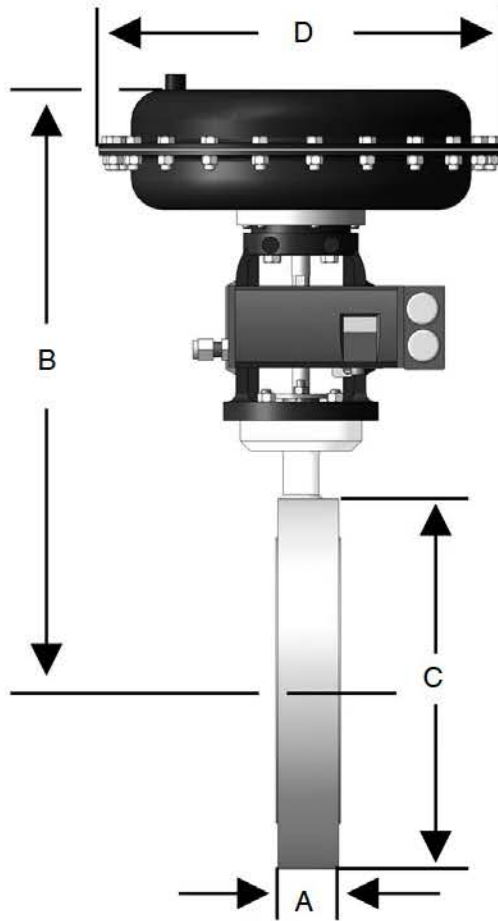

**INCHES**

Valve Size	Act. Size	Dimensions				Weight Lbs
		A	B	C	D	
1"	35M	1.24	10.54	2.76	9.50	18
	55M				12.50	28
1-1/2"	35M	1.36	10.82	3.24	9.50	20
	55M				12.50	30
2"	35M	1.76	11.17	3.98	9.50	20
	55M				12.50	30
2-1/2"	35M	1.81	14.08	4.36	9.50	30
	55M				12.50	40
3"	35M	1.81	14.86	5.25	9.50	42
	55M				12.50	52
4"	55M	2.06	17.98	6.46	12.50	51
	85M				15.00	61
6"	55M	2.23	19.30	8.62	12.50	67
	85M				15.00	77
8"	100M	2.38	21.91	13.75	15.00	131

**METRIC**

Valve Size	Act. Size	Dimensions				Weight Kgs
		A	B	C	D	
DN25	35M	31,5	268	70	241	8,2
	55M				318	12,7
DN40	35M	34,5	275	82	241	9,1
	55M				318	13,6
DN50	35M	44,7	284	101	241	9,1
	55M				318	13,6
DN65	35M	46,0	358	111	241	13,6
	55M				318	18,1
DN80	35M	46,0	377	133	241	19,1
	55M				318	23,6
DN100	55M	52,3	457	164	318	23,1
	85M				381	27,7
DN150	55M	56,6	490	219	318	30,4
	85M				381	34,9
DN200	100M	60,5	557	350	381	59,4

MARK 75 SERIES WAFER STYLE CONTROL VALVES

ORDERING SCHEMATIC MARK 75

Model No	Size	Body Mat'l	1	2	3	4	5	6	7	8	9	10	11	12	13	14	15	16	17	18

Model	
75	Standard
75SP	Side Mounted Positioner
75TP	Top Mounted Positioner

Size	
100	1"
150	1-1/2"
200	2"
250	2-1/2"
300	3"
400	4"
600	6"
800	8" (available with 75SP only)

Body Material	
CB	Carbon Steel Bar
SB	Stainless Steel Bar
CS	Carbon Steel Cast
S6	Stainless Steel Cast

End Connections	
I3	150# / 300# IFE
I5	150# Bolt Thru (8" only)
ZZ	Non-Standard

Trim	
T6	316SS / PTFE Packaging
I6	316SS / 287-I Packaging
ZZ	Non-Standard

5 & 6 Seats			
Material		Cv	
W	316SS / Jorcote	8	9.5
		A	33
		B	38
		E	72
		F	76
		H	103
		I	180
		J	400
		K	600
ZZ	Non-Standard		

Consult factory for equal percentage requirements

7 & 8 Range			
75, 75TP			
Range		Actuator	
A	3-15 DIR	3	35M
B	3-15 REV	5	55M
C	3-9 DIR**	8	85M
D	3-9 REV**		
E	9-15 DIR**		
F	9-15 REV**		
G	6-30 DIR		
H	6-30 REV		
75SP			
A	DIR	3	35M
B	REV	5	55M
		8	85M
		9*	100M
ZZ	Non-Standard		

\* 8" MK75SP only

\*\* positioner required

9 & 10 Diaphragm			
Material		Size	
B	Buna-N	3	35M
		5	55M
		8	85M
		9*	100M
ZZ	Non-Standard		

\* 8" MK75SP only

Continued on next page

ORDERING SCHEMATIC CONTINUED

11 & 12	Actuator
A3	35M
A5	55M
A8	85M
A9*	100M
ZZ	Non-Standard

\* 8" MK75SP only

13 & 14	Accessory 1
00	None
AR	Air Regulator
H5	Handwheel 55M Actuator
H8	Handwheel 85M Actuator
H9*	Handwheel 100M Actuator
ZZ	Non-Standard

\* 8" MK75SP only

15	Action
D	Air-To-Close
R	Air-To-Open
ZZ	Non-Standard

16	Accessory 2
0	None
3	I/P 35M Act. 4-20 Ma/3-15 psi
5	I/P 55M Act. 4-20Ma/3-15 psi
8	I/P 85M Act. 4-20Ma/3-15 psi
9	I/P 35M/55M/85M Act. 4-20Ma/6-30 psi
Z	Non-Standard

17	PED Compliance
0	Not Required
F	CE Category 1
Z	Non-Standard

18	SMP
0	None
A	SMP DIR/REV 3-15
B	SMP DIR/REV 3-9
C	SMP DIR/REV 9-15
D	SMP/IP DIR/REV 4-20
E	SMP/IP DIR/REV 4-12
F	SMP/IP DIR/REV 12-20
G	MK16IQ DIR/REV 4-20 (Hart & FM-App)
H	MK16IQ-B DIR/REV 4-20 (with gauges)
J	MK16IQ-FF DIR/REV 4-20 (Fieldbus w/gauges)
Z	Non-Standard

**ORDERING SCHEMATIC MK75MV WITH MOTOR VALVE**

Model No	Size	Body Mat'l	1	2	3	4	5	6	7	8	9	10	11	12	13	14	15

	Model
75MV	with Motor Valve

	Size
100	1"
150	1-1/2"
200	2"
250	2-1/2"
300	3"
400	4"
600	6"

	Body Material
CB	Carbon Steel Bar
SB	Stainless Steel Bar
CS	Carbon Steel Cast
S6	Stainless Steel Cast

1 & 2	End Connections
I3	150# / 300# IFE
ZZ	Non-Standard

3 & 4	Trim
T6	316SS / TEF Packing
I6	316SS / 287-I Packing
ZZ	Non-Standard

5 & 6	Seats		
	Material	Cv	
W	316SS / Jorcote	8	9.5
		A	33
		B	38
		E	72
		F	76
		H	103
		I	180
		J	400
ZZ	Non-Standard		

7 & 8	Range
42	4-20mA
41	4-12mA
12	12-20mA
VS	0-5 VDC
V1	0-10 VDC
NF	On/Off
NN	No Motor
ZZ	Non-Standard

9 & 10	Actuator/Yoke Feat
A1	MV1010 - 120/240 VAC
A2	MV1020 - 120/240 VAC
ZZ	Non-Standard

11 & 12	Accessory 1
00	None
SC	Clean for Oil Free
XC	Oxygen Clean

13 & 14	Action
DD	Direct
RR	Reverse
DP	Direct/Fail Open on LOS
RC	Reverse/Fail Closed on LOS

15	PED Compliance
0	Not Required
F	CE Category 1
Z	Non-Standard

