

# Loop Leader PD6602/4 Loop-Powered Process Meter Instruction Manual



## Loop-Powered Process

- Loop-Powered Process Meter
- Loop-Powered Backlight with Red Backlight for Alarm Conditions
- 1.5 Volt Drop (4.5 Volt Drop w/ Backlight)
- IP65 Front
- -40 to 167°F (-40 to 75°C) Operating Temperature Range
- Five Digit Top Line
- Alphanumeric Tag Names
- Dual-Line Display
- 1/8 DIN Shallow Depth Case
- Optional Loop-Powered Solid-State Relays
- Optional 4-20 mA Analog Output
- Open Collector Output Standard
- Optional Bargraph Display (PD6604)
- Timer functions for open collectors and relays
- Relay Pump Alternation Based on Level and Time
- Relay Runtime and Cycle Count

## PRECISION DIGITAL CORPORATION



233 South Street • Hopkinton MA 01748 USA  
Tel (800) 343-1001 • Fax (508) 655-8990

**PRECISION  
DIGITAL** 

[www.predig.com](http://www.predig.com)

## Disclaimer

The information contained in this document is subject to change without notice. Precision Digital makes no representations or warranties with respect to the contents hereof and specifically disclaims any implied warranties of merchantability or fitness for a particular purpose.

	
<b>CAUTION:</b> <i>Read complete instructions prior to installation and operation of the meter.</i>	<b>WARNING:</b> <i>Risk of electric shock or personal injury.</i>

 <b>Warning!</b>	<b><i>This product is not recommended for life support applications or applications where malfunctioning could result in personal injury or property loss. Anyone using this product for such applications does so at his/her own risk. Precision Digital Corporation shall not be held liable for damages resulting from such improper use.</i></b>
--	--

## Limited Warranty

Precision Digital Corporation warrants this product against defects in material or workmanship for the specified period under “Specifications” from the date of shipment from the factory. Precision Digital’s liability under this limited warranty shall not exceed the purchase value, repair, or replacement of the defective unit.

## Registered Trademarks

NORYL® and LEXAN® are registered trademarks of SABIC Innovative Plastics. All other trademarks mentioned in this document are the property of their respective owners.

© 2016-2017 Precision Digital Corporation. All rights reserved.

**[www.predig.com](http://www.predig.com)**

## Table of Contents

<b>Table of Contents</b> .....	<b>3</b>	Scaling the 4-20 mA Input .....	19
<b>Table of Figures</b> .....	<b>3</b>	<b>Setting the Display Features (DISPLAY)</b> .....	<b>19</b>
<b>Introduction</b> .....	<b>4</b>	Changing the Units (UNITS) .....	19
<b>Ordering Information</b> .....	<b>4</b>	Changing the Decimal Place Location (DECP) .....	19
<b>Specifications</b> .....	<b>5</b>	Enabling or Disabling the Comma on the Bottom	
<b>General</b> .....	<b>5</b>	Display (COMMA) .....	19
<b>Process Input</b> .....	<b>5</b>	Changing What is Displayed (TOP and BOTTOM) .....	20
<b>Open Collector Output</b> .....	<b>6</b>	Programming the Bargraph (PD6604 Only) .....	21
<b>Solid State Relays</b> .....	<b>6</b>	<b>Programming the Outputs (OUTPUT)</b> .....	<b>21</b>
<b>4-20 mA Transmitter Output</b> .....	<b>6</b>	Open Collector Outputs (OPEN COLLECTR) .....	22
<b>Safety Information</b> .....	<b>7</b>	Solid State Relay Outputs (RELAY) .....	25
<b>Installation</b> .....	<b>7</b>	4-20 mA Output (4-20 mA) .....	31
<b>Unpacking</b> .....	<b>7</b>	Output Control (CONTROL) .....	31
<b>Panel Mounting Instructions</b> .....	<b>7</b>	<b>Advanced Features Menu (ADVANCED)</b> .....	<b>32</b>
Mounting Dimensions .....	8	Advanced Process Variable Setup (ADV PV SETUP) .....	33
<b>Connections</b> .....	<b>8</b>	Low-Flow Cutoff (CUTOFF) .....	35
Connectors Labeling .....	8	Noise Filter (FILTER) .....	35
Current Loop (4-20 mA) Connections .....	9	Enabling Password Protection (PASSWORD) .....	35
Digital Input Connection .....	9	Programmable Function Keys User Menu (USER) .....	36
4-20 mA Output Connections .....	10	Changing System Settings (SYSTEM) .....	37
Solid State Relay Connections .....	10	<b>Meter Operation</b> .....	<b>39</b>
Open Collector Outputs .....	11	<b>Front Panel Buttons Operation</b> .....	<b>39</b>
<b>Setup and Programming</b> .....	<b>12</b>	<b>Function Keys Operation</b> .....	<b>39</b>
<b>Overview</b> .....	<b>12</b>	<b>Digital Input Operation</b> .....	<b>39</b>
<b>Front Panel Buttons and Status LED Indicators</b> .....	<b>12</b>	<b>Maximum/Minimum Readings</b> .....	<b>39</b>
<b>Display Functions &amp; Messages</b> .....	<b>13</b>	<b>Changing Engineering Units</b> .....	<b>39</b>
<b>Main Menu</b> .....	<b>16</b>	<b>Troubleshooting</b> .....	<b>40</b>
Setting Numeric Values .....	16	<b>Reset Meter to Factory Defaults</b> .....	<b>40</b>
<b>Setting Up the Input Signal (INPUT)</b> .....	<b>17</b>	<b>Determining Software Version</b> .....	<b>40</b>
Available Unit Classes and Units .....	18	Factory Default Settings .....	41
Setting Custom Units (CUSTOM) .....	18	<b>Troubleshooting Tips</b> .....	<b>42</b>

## Table of Figures

Figure 1. 1/8 DIN Panel Cutout Dimensions and Panel Mounting Details .....	7	Figure 6. 4-20 mA Input Connection with Backlight .....	9
Figure 2. Meter Dimensions - Side View .....	8	Figure 7. Digital Input Connections .....	9
Figure 3. Meter Dimensions - Front View .....	8	Figure 8. 4-20 mA Output Connections .....	10
Figure 4. Connector Labeling for Fully Loaded PD6600 .....	8	Figure 9. Solid State Relay Connections .....	10
Figure 5. 4-20 mA Input Connection without Backlight .....	9	Figure 10. Open Collector Output Connections .....	11

## Introduction

The Loop Leader PD6602 and PD6604 are general-purpose, loop-powered meters. The four front panel buttons make setup and programming of the meter simple and intuitive. A dual-line display featuring five digits on the top line and eight digits on the bottom line, preprogrammed engineering units, and optional bargraph display (PD6604) provide a clear and attractive presentation of the process. The units of measure can be changed as needed within a unit type (e.g. volume, temperature, pressure) without the need to re-scale the meter.

The dual-line display can be customized by the user to operate in such a way as to satisfy a specific application. Typically, the top line is used for the process variable while the bottom line is used for engineering units, custom tag, or process variable percentage of full scale. Three programmable function keys and a digital input come standard and allow the meter to be customized for use in specialized applications.

All models come equipped with two open collector outputs and are available with two solid state relays and a 4-20 mA analog output. These outputs can be programmed for alarm indication, signal retransmission via pulse or analog signal, pump control, and a number of other useful features.

The fact that this meter is loop-powered means that there is no need to run additional, costly power lines; the meter gets all of the power it needs from the 4-20 mA loop. The Loop Leader loop-powered meter is built in a shallow-depth case with an IP65 front and features loop-powered backlighting and a wide -40 to 167°F (-40 to 75°C) operating temperature range. It doesn't matter if it's indoors or outdoors, in bright sunlight or a dimly lit plant, or in an area that is wet, dirty, hot, or cold, the Loop Leader can go just about anywhere.

## Ordering Information

### Standard Decimal Display Models

Model	Description
PD6602-LNN	Loop-Powered, No Options
PD6602-L2N	Loop-Powered, Two Solid State Relays
PD6602-L3N	Loop-Powered, 4-20 mA Analog Output
PD6602-L5N	Loop-Powered, Two Solid State Relays and 4-20 mA Analog Output
<b>Note:</b> all models come with two open collector outputs standard.	

### Decimal Display with Bargraph Models

Model	Description
PD6604-LNN	Loop-Powered, No Options
PD6604-L2N	Loop-Powered, Two Solid State Relays
PD6604-L3N	Loop-Powered, 4-20 mA Analog Output
PD6604-L5N	Loop-Powered, Two Solid State Relays and 4-20 mA Analog Output
<b>Note:</b> all models come with two open collector outputs standard.	

### Enclosures

Model	Meters	Description	Mounting
PDA2407	1	Plastic NEMA 4X Enclosure	Inside Cover
PDA2410	3	Plastic NEMA 4X Enclosure	Inside Cover
PDA2411	2	Plastic NEMA 4X Enclosure	Inside Cover
PDA23XX	1-10	Economical Plastic NEMA 4X Enclosure	Through Door
PDA25XX	1-10	Plastic NEMA 4X Enclosure	Through Door
PDA26XX	1-6	Stainless Steel NEMA 4X Enclosure	Through Door
PDA27XX	1-6	Steel NEMA 4 Enclosure	Through Door
PDA2801*	1	Low-Cost Plastic NEMA 4X Enclosure	Through Cover
PDA2812	2	Low-Cost Plastic NEMA 4X Enclosure	Through Cover

**Note:** XX = the last two digits of the model number.

Go to [www.predig.com](http://www.predig.com) to find individual part numbers.

# Specifications

Except where noted all specifications apply to operation at +25°C.

## General

<b>Display</b>	Top: 0.7" (17.8 mm), Bottom: 0.4" (10.2 mm); 14-segment alphanumeric Top: 5 digits -9999 to 99999 Bottom: 8 digits -9,999,999 to 99,999,999 Bottom line separated by commas
<b>Display Update Rate</b>	Ambient > -10°C: 1 Update/Second Ambient > -20°C: 1 Update/2 Seconds Ambient -40°C: 1 Update/10 Seconds
<b>Overrange</b>	Top: 99999; Bottom: 99,999,999 (flashing)
<b>Underrange</b>	Top: -9999; Bottom: -9,999,999 (flashing)
<b>Programming Method</b>	Front panel
<b>Noise Filter</b>	1, 2, 4, 8, 16 sec.
<b>Noise Filter Bypass</b>	0.1 to 99.9% FS
<b>Recalibration</b>	Recalibration is recommended at least every 12 months.
<b>Max/Min Display</b>	Max/min readings reached by the process are stored until reset by the user or until power to the meter is turned off.
<b>Password</b>	Programmable password restricts modification of programmed settings.
<b>Non-Volatile Memory</b>	All programmed settings are stored in non-volatile memory for a minimum of ten years if power is lost.
<b>Normal Mode Rejection</b>	64 dB at 50/60 Hz
<b>Environmental</b>	Operating temperature range: -40 to 75°C Storage temperature range: -40 to 85°C Relative humidity: 0 to 90% non-condensing
<b>Connections</b>	Removable screw terminals accept 12 to 22 AWG wire
<b>DI Digital Input Contacts</b>	2.1 VDC on contact. Connect normally open contacts across DI+ to DI-
<b>DI Digital Input Logic Levels</b>	Logic High: 2.4 to 30 VDC (max) Logic Low: 0 to 0.9 VDC
<b>Enclosure &amp; Materials</b>	1/8 DIN, high impact plastic, NORYL® Polyphenylene Ether & Polystyrene blend (PPE PS) Resin, UL 94V-0, color: gray Gasket: Silicone Rubber Faceplate: LEXAN® Polycarbonate (PC) Film Buttons: Silicone rubber; Color: black
<b>Mounting</b>	1/8 DIN panel cutout required. Two panel mounting bracket assemblies provided
<b>Tightening Torque</b>	Screw terminal connectors: 4.5 lb-in (0.5 Nm) Mounting screws: 8.0 lb-in max. (0.9 Nm)
<b>Overall Dimensions</b>	4.68" x 2.45" x 3.79" (119 mm x 62 mm x 96 mm) (W x H x D)
<b>Weight</b>	8.7 oz (247g) w/ option board
<b>Warranty</b>	3 years parts and labor

## Process Input

<b>Accuracy</b>	±0.02% of span ±1 count, Square root and programmable exponent: 10-100% FS
<b>Function</b>	PV1: Linear, square root, or programmable exponent PV2: Linear or Round Horizontal Tank
<b>Low-Flow Cutoff</b>	0.0 to 999,999.9
<b>Temperature Drift</b>	25 PPM/°C from -40 to 75°C ambient
<b>Decimal Point</b>	Up to four decimal places: On top Up to seven decimal places: On bottom
<b>Scaling and Display Range</b>	Input: 4-20 mA Scaling Range: -999,999.9 to 999,999.9 Display Range: Top Line: -9999 to 99999; Bottom Line: -9,999,999 to 99,999,999
<b>Voltage Drop</b>	With backlight off: 1.5 V max With backlight on: 4.5 V max
<b>Equivalent Resistance</b>	75 Ω @ 20 mA with backlight off 225 Ω @ 20 mA with backlight on
<b>Input Overload</b>	Over current protection to 1 A maximum



### Open Collector Output

<b>Rating</b>	Two NPN, Isolated open collector, 30 VDC @ 90 mA maximum
<b>Output Assignment</b>	Pulse, Alarm, Timer, or Disable
<b>Pulse Output Source</b>	PV (PV1, PV2) or Test Frequency
<b>Pulse Output Factor</b>	0.000001 to 999,999.9
<b>Pulse Width</b>	Min: 2 ms @ 250 Hz; 50% duty cycle Max: 250 ms @ < 2 Hz
<b>Pulse Output Frequency</b>	250 Hz maximum 0.1 Hz minimum
<b>Quadrature Pulse Output</b>	Available for Output 2 (90° behind Output 1)
<b>Alarm Output Source</b>	Assign to PV (PV1, PV2) or Digital Input
<b>High or Low Alarm</b>	User programmable for high or low alarm
<b>Alarm Deadband</b>	0-100% FS, user programmable
<b>On &amp; Off Time Delay</b>	0 to 9,999 seconds
<b>Fail-Safe Operation</b>	Independent for each output
<b>Alarm Operation</b>	Auto, Auto-man, Latch, Latch w/clear
<b>Alarm Indication</b>	Red backlight, Flashing display, Alarm symbol (!)
<b>Alarm Message</b>	On or Off; User programmable, 8 characters maximum Displayed every 10 sec for 1 sec on bottom
<b>Alarm Acknowledge</b>	Front panel ACK button or external digital input resets output and screen indication
<b>Auto Initialization</b>	When power is applied to the meter, relays will reflect the state of the input to the meter
<b>Timer Output</b>	One-shot or Continuous Off Time Delay: 1 sec to 99:59:59 (hrs:min:sec) On Time: 1 sec to 99:59:59 (hrs:min:sec)
<b>Timer Start/Stop</b>	Front panel or digital input, user selectable

### Solid State Relays

<b>Rating</b>	Resistive Load: 250 VAC/DC @ 1 Amp Inductive Load: 1/10 HP @ 125/250 VAC/DC
<b>Noise Suppression</b>	Metal oxide varistors across outputs
<b>Relay Assignment</b>	Alarm, Pump Control, Timer, or Disable Pump Alternation Time: 0 to 999:59 (hrs:min)
<b>Alarm Output Source</b>	Assign to PV (PV1, PV2) or Digital Input
<b>High or Low Alarm</b>	User programmable for high or low alarm
<b>Alarm Deadband</b>	0-100% FS, user programmable
<b>On &amp; Off Time Delay</b>	0 to 9,999 seconds
<b>Fail-Safe Operation</b>	Independent for each relay
<b>Alarm Operation</b>	Auto, Auto-man, Latch, Latch w/clear
<b>Alarm Indication</b>	Red backlight, Flashing display, Alarm Message, Alarm symbol (!)
<b>Alarm Message</b>	On or Off; User programmable, 8 characters maximum. Displayed every 10 sec for 1 sec on bottom
<b>Alarm Acknowledge</b>	Front panel ACK button or external digital input resets output and screen indication
<b>Auto Initialization</b>	When power is applied to the meter, relays will reflect the state of the input to the meter
<b>Timer Output</b>	One-shot or Continuous Off Time Delay: 1 sec to 99:59:59 (hrs:min:sec) On Time: 1 sec to 99:59:59 (hrs:min:sec)
<b>Timer Start/Stop</b>	Front panel or digital input, user selectable
<b>4-20 mA Transmitter Output</b>	
<b>Output Source</b>	PV1, PV2, re-transmit; reverse scaling allowed
<b>Scaling Range</b>	1.00 to 23.0 mA
<b>Disable</b>	High impedance state, less than 1 mA
<b>Calibration</b>	Factory calibrated 4.00 to 20.00 mA
<b>Underrange</b>	1.0 mA, 3.5 mA, or 3.8 mA (If input < 3.5 mA); or Off; user selectable
<b>Overrange</b>	20.5 mA, 20.8 mA, or 23.0 mA (If input > 20.5 mA); or Off; user selectable
<b>Isolation</b>	500 V
<b>Accuracy</b>	±0.05% FS ±0.001mA
<b>Temperature Drift</b>	0.5 µA/°C max from -40 to 75°C ambient
<b>External Loop Power Supply</b>	7.0 VDC to 30.0 VDC maximum
<b>Output Loop Resistance</b>	10-750 Ω @ 24 VDC; 10-1100 Ω @ 30 VDC

## Safety Information

 <b>CAUTION:</b> Read complete instructions prior to installation and operation of the meter.	 <b>WARNING:</b> Risk of electric shock or personal injury.
---	--

 <b>Warning!</b>	<b>Hazardous voltages exist within enclosure. Installation and service should be performed only by trained service personnel.</b>
--	---

## Installation

There is no need to remove the meter from its case to complete the installation, wiring, and setup of the meter for most applications.

## Unpacking

Remove the meter from box. Inspect the packaging and contents for damage. Report damages, if any, to the carrier.

If any part is missing or the meter malfunctions, please contact your supplier or the factory for assistance.

## Panel Mounting Instructions

- Prepare a standard 1/8 DIN panel cutout – 3.622" x 1.772" (92 mm x 45 mm). Refer to Figure 1 below, for more details.
- Clearance: allow at least 4.0" (102 mm) behind the panel for wiring.
- Panel thickness: 0.04" - 0.25" (1.0 mm - 6.4 mm).  
Recommended minimum panel thickness to maintain Type 4X rating: 0.06" (1.5 mm) steel panel, 0.16" (4.1 mm) plastic panel.
- Remove the two mounting brackets provided with the meter (back-off the two screws so that there is ¼" (6.4 mm) or less through the bracket. Slide the bracket toward the front of the case and remove).
- Insert meter into the panel cutout.
- Install mounting brackets and tighten the screws against the panel. To achieve a proper seal, tighten the mounting bracket screws evenly until meter is snug to the panel along its short side. **DO NOT OVER TIGHTEN**, as the rear of the panel may be damaged.

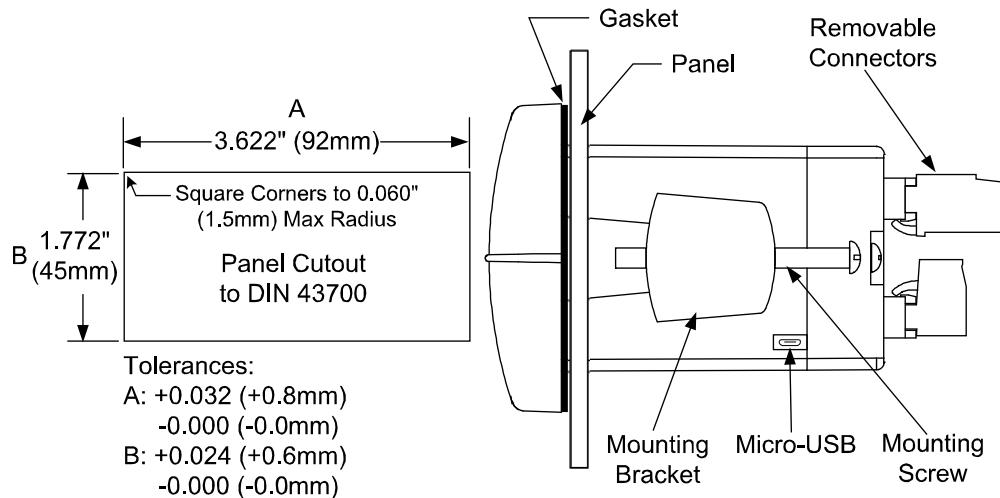

**Figure 1. 1/8 DIN Panel Cutout Dimensions and Panel Mounting Details**

### Mounting Dimensions

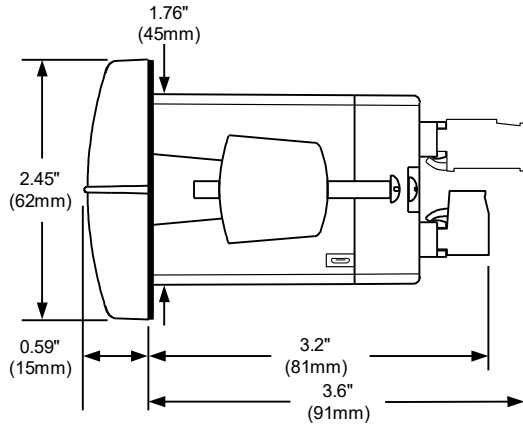

Figure 2. Meter Dimensions - Side View

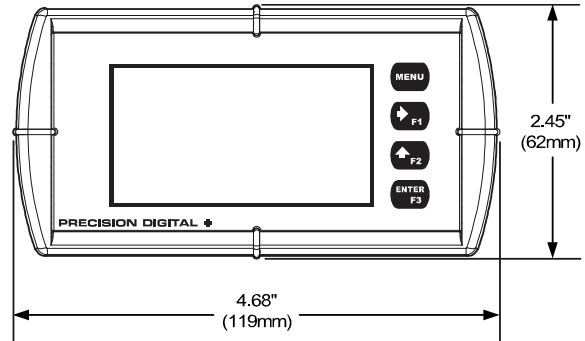



Figure 3. Meter Dimensions - Front View

### Connections

All connections are made to removable screw terminal connectors located at the rear of the meter.



*Use copper wire with 60°C or 60/75°C insulation for all line voltage connections. Observe all safety regulations. Electrical wiring should be performed in accordance with all applicable national, state, and local codes to prevent damage to the meter and ensure personnel safety.*

### Connectors Labeling

The connectors' label, affixed to the meter, shows the location of all connectors available with requested configuration.

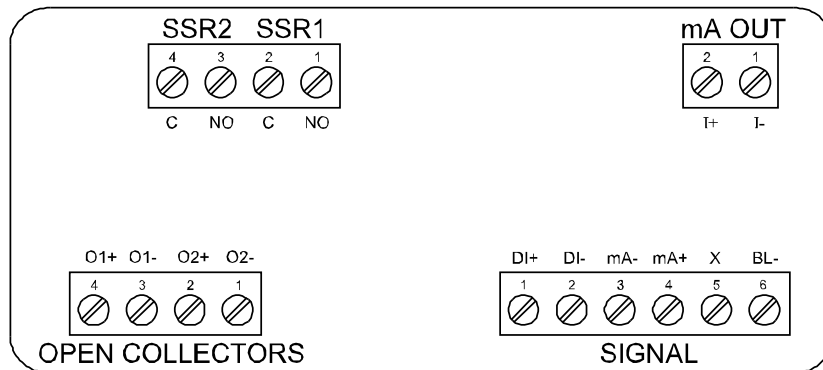

Figure 4. Connector Labeling for Fully Loaded PD6600



### Current Loop (4-20 mA) Connections

Signal connections are made to a six-terminal connector labeled SIGNAL on Figure 4. The following figures show a 4-20 mA current loop connected to the meter. The first figure shows the connection without the backlight and the second shows the connection with the backlight (the backlight can be disabled/enabled in the SYSTEM menu). The meter is powered by the 4-20 mA current loop. There are no switches or jumpers to set up for the input. Setup and programming is performed through the front panel buttons.

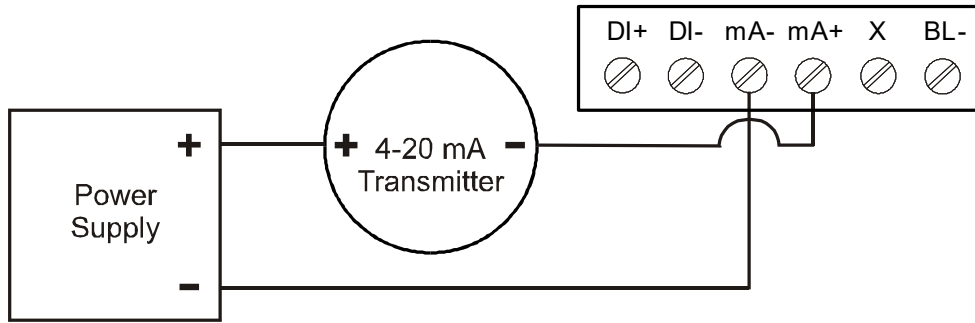

Figure 5. 4-20 mA Input Connection without Backlight

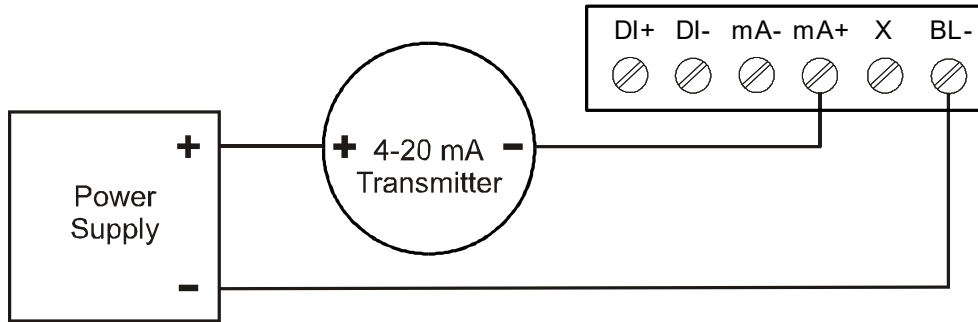

Figure 6. 4-20 mA Input Connection with Backlight

The current input is protected against current overload up to 1 amp. The display may or may not show a fault condition depending on the nature of the overload.

### Digital Input Connection

A digital input is standard on the meter. This digital input is connected with a normally open contact across DI+ and DI-, or with an active low signal applied to DI+ and DI-.

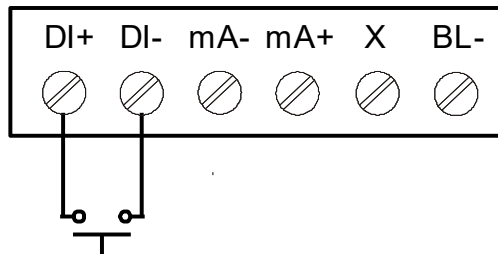

Figure 7. Digital Input Connections

### 4-20 mA Output Connections

Connections for the 4-20 mA transmitter output are made to the connector terminals labeled mA OUT. The 4-20 mA output must be powered from an external power supply.

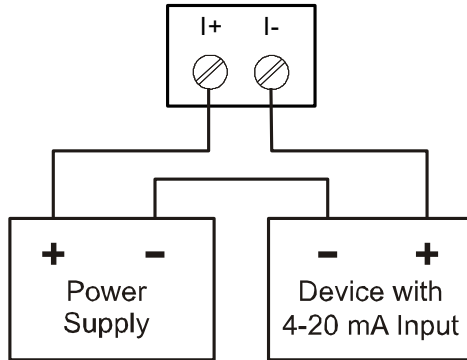

Figure 8. 4-20 mA Output Connections

### Solid State Relay Connections

Relay connections are made to two-terminal connectors labeled SSR1 and SSR2 in Figure 4. Each relay's C terminal is common only to the normally open (NO) contact of the corresponding relay.

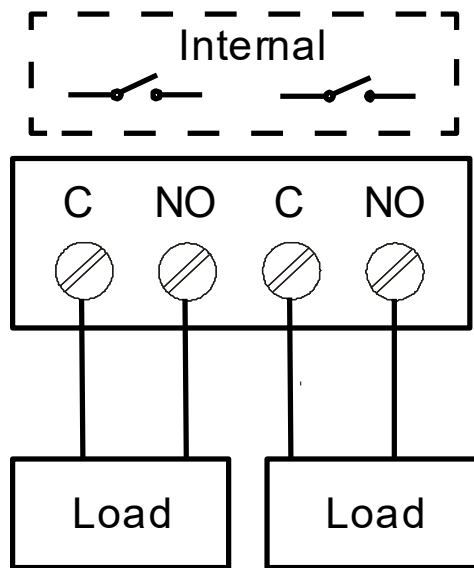

Figure 9. Solid State Relay Connections

### Open Collector Outputs

Open collector output 1 and 2 connections are made to terminals labeled O1+ and O1-, and O2+ and O2-. Connect the alarm or pulse input device as shown below.

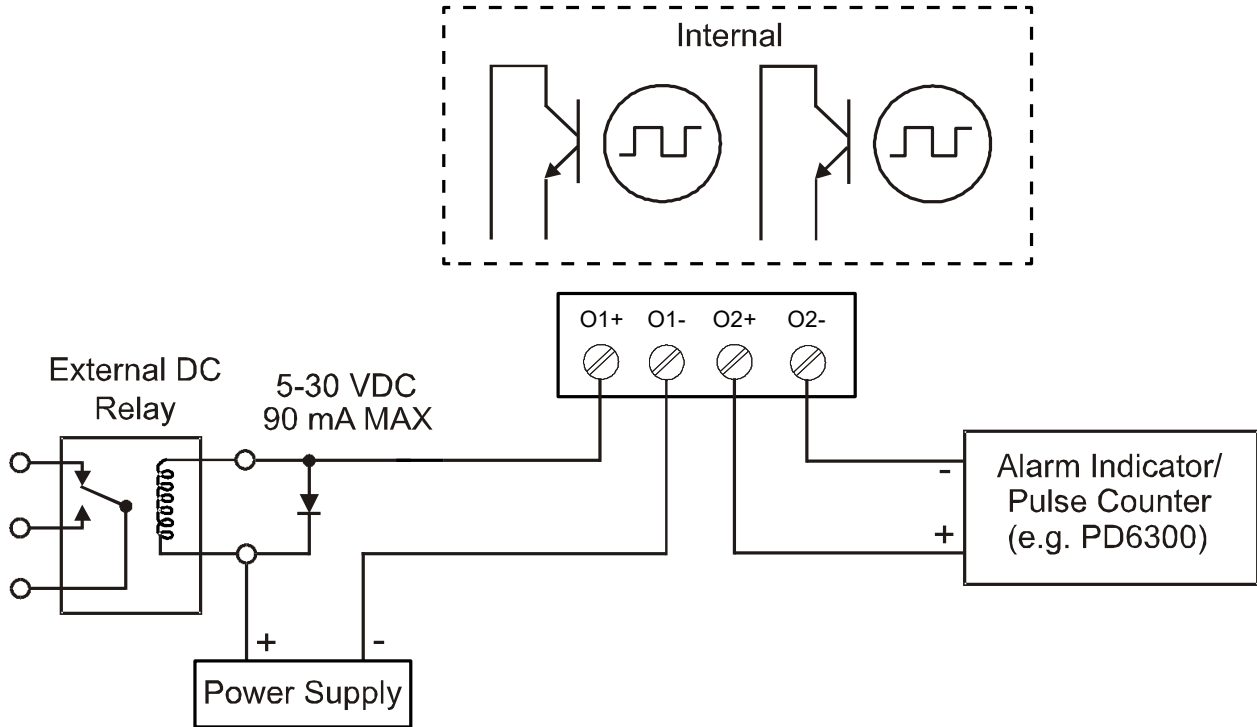

Figure 10. Open Collector Output Connections

## Setup and Programming

The meter is factory calibrated prior to shipment to display 0 to 100, which corresponds to the 4-20 mA input. The calibration equipment is certified to NIST standards.

### Overview

There are no jumpers to set; setup and programming is done through the front panel buttons. The meter may be powered via the micro-USB connection located on the right side of the meter for the purposes of programming only. The backlight will not work while the meter is powered via the USB connection.

### Front Panel Buttons and Status LED Indicators



PD6602

PD6604

Button Symbol	Description
	Menu
	Right-Arrow/F1
	Up-Arrow/F2
	Enter/F3

LED	Status
	Alarm Indicator (PD6602 Only)
	Password Protection Indicator (PD6602 Only)
	PV Bargraph (PD6604 Only)

- Press the **Menu** button to enter or exit the *Programming Mode* at any time.
- Press or hold the **Right Arrow** button to scroll forward through the menus, select digits during numeric programming, select characters during text programming, or decrement the value of a digit or character selected with the **Up-Arrow** button.
- Press and hold the **Right-Arrow** button to zero or clear digits/characters while in data-entry mode.
- Press or hold the **Up-Arrow** button to scroll backwards through the menus or to increment the value of a digit or character.
- Press the **Enter** button to access a menu or to accept a setting or programmed digit/character value.

## Display Functions & Messages

The meter displays various functions and messages during setup, programming, and operation. The following table shows the main menu functions and messages in the order they appear in the menu.

Parameter	Action/Setting Description	Parameter	Action/Setting Description
INPUT (PV 1 & PV 2)	Program the meter 4-20 mA input (two menus, PV 1 and PV 2, are available if in dual scale mode; see PV 2 under advanced features menu)	WEIGHT	Weight unit class
SCALE PV (1 or 2)	Scale the selected PV	Gm	Grams
UNITS	Select the display units	KG	Kilograms
VOLUME	Volume unit class	TONNE	Tonnes (metric)
GAL	Gallons	oz	Ounces
L	Liters	lb	Pounds
IGAL	Imperial Gallons	TON	Tons
M3	Cubic Meters	CUSTOM	Custom unit
BBL	Barrels	RATE	Rate unit class
BUSH	Bushels	/SECOND	Units per second
CYD	Cubic Yards	/MINUTE	Units per minute
CuFt	Cubic Feet	/HOUR	Units per hour
CuIn	Cubic Inches	/DAY	Units per day
L, BBL	Liquid barrels	GAL/(T)	Gallons per time unit (T)
BBBL	Beer barrels	L/(T)	Liters per time unit (T)
HECLL	Hectoliter	IGAL/(T)	Imperial gallons per time unit (T)
AF	Acre-Foot	M3/(T)	Cubic meters per time unit (T)
CUSTOM	Custom Unit	BBL/(T)	Barrels per time unit (T)
HEIGHT	Height unit class	BUSH/(T)	Bushels per time unit (T)
INCH	Inches	CuYD/(T)	Cubic Yards per time unit (T)
FEET	Feet	CuFt/(T)	Cubic Feet per time unit (T)
FT-IN	Feet & Inches	CuIn/(T)	Cubic Inches per time unit (T)
YARD	Yards	L, BBL/(T)	Liquid barrels per time unit (T)
CM	Centimeters	BBBL/(T)	Beer barrels per time unit (T)
M	Meters	HECLL/(T)	Hectoliter per time unit (T)
CUSTOM	Custom unit	AF/(T)	Acre-Foot per time unit (T)
TEMP	Temperature unit class	CUSTOM/	Custom unit per time unit (T)
oF	Degrees Fahrenheit	CUSTOM	Custom unit class
oC	Degrees Celsius	CUNIT	Custom unit
K	Kelvin	INPUT 1	Program input 1 value
oRA	Degrees Rankine	INP 1	Enter the input 1 value
PRESSURE	Pressure unit class	DISP 1	Program display 1 value
PSI	Pounds per square inch	DISP 1	Enter the display 1 value
InHG	Inches of mercury	INPUT 2	Program input 2 value (up to 32 points)
InH2O	Inches of water	INP 2	Enter the input 2 value
mmHG	Millimeters of mercury	DISP 2	Program display 2 value (up to 32 points)
KG/CM2	Kilograms per square centimeter	DISP 2	Enter the display 2 value
KG/M2	Kilograms per square meter	SAVE?	Save programmed units, input, and display values
mBAR	Millibar	OUTPUT	Program the meter's available outputs
BAR	Bar	OPEN COLLECTR	Program the meter's open collector outputs
PA	Pascal	OUTPUT 1	Open collector 1 setup
HPA	Hectopascal	OUTPUT2	Open collector 2 setup
KPA	Kilopascal	DISABLE	Disable the open collector
MPA	Megapascal		
CUSTOM	Custom unit		

Parameter	Action/Setting Description	Parameter	Action/Setting Description
PULSE	Program the open collector for pulse output	SCALE PV	Scale the input
ALARM	Program the open collector for alarm output	CAL PV	Calibrate the input
TIMER	Program the open collector as a timer	CUTOFF	Set low-flow cutoff
RELAY	Program the meter's relay outputs	DISABLE	Disable low-flow cutoff
OUTPUT 1	Relay 1 setup	ENABLE	Enable low-flow cutoff
OUTPUT 2	Relay 2 setup	FILTER	Set noise filter value
DISABLE	Disable the relay	20 SEC	2 seconds
ALARM	Program relay for alarm functionality	40 SEC	4 seconds
PUMPCAL	Program relay for pump control application	80 SEC	8 seconds
TIMER	Program relay as a timer	160 SEC	16 seconds
RELAY INFO	View relay run time and cycle count	OFF	Turn filter off
4-20 mA	Program the meter's 4-20 mA output	10 SEC	1 second
PV	Program a range to transmit based on the display value	PASSWD	Set a password for the meter
RETRANS	Retransmit the mA input signal	PASS MAIN	Program the main meter password
DISABLE	Disable the 4-20 mA output	USER	Assign function keys / digital input
CONTROL	Program manual or automatic operation for the outputs	F 1	Assign F1 function key
OC 1	Open collector 1	F 2	Assign F2 function key
OC 2	Open collector 2	F 3	Assign F3 function key
RELAY 1	Relay 1	DI	Assign digital input
RELAY 2	Relay 2	DISP FN	Set the function key or digital input to display a value
4-20 mA	4-20 mA output	DISPLAY	Cycle max, min, and PV(s)
AUTO	Set selected output to automatic operation	DISP PV	Display the PV
MANUAL	Manually control selected output operation	PCT PV	Display the PV's percentage of max (20 mA)
ADVANCED	Program the meter's advanced features	UNITS	Display the PV's units
PV SETUP (PV 1 & PV 2)	Advanced input programming (two menus, PV 1 and PV 2, are available if in dual scale mode; see PV 2 under advanced features menu)	TAG	Display the PV's tag
SOURCE	Select PV 2 source (dual-scale only; see PV 2 under advanced features menu)	DISP MIN	Display the PV's minimum value
4-20 mA	Source PV 2 from the mA input	DISP MAX	Display the PV's maximum value
PV 1	Source PV 2 from PV 1	MIN MAX	Display the PV's minimum and maximum value
FUNCTION	Select linear, square root, or programmable exponent function	mA IN	Display the current mA input value
LINEAR	Set meter for linear function and select number of linearization points	mA OUT	Display the current mA output value
SQROOT	Set meter for square root extraction	MENU FN	Set the function key or digital input to access a menu
EXPONENT	Set meter for programmable exponent and enter exponent value	RLY INFO	Go to relay information menu (INFO)
RH TANK	Round horizontal tank (dual-scale only; see PV 2 under advanced features menu)	MANCTRL	Go to output control menu (CONTROL)
SCALECAL	Scale or calibrate the mA input	TIMERFN	Set the function key or digital input to start or stop a timer
		STARTALL	Start all timers
		STOPALL	Stop all timers
		SSTPALL	Start or stop all timers
		OC 1	Start/stop open collector 1 timer
		OC 2	Start/stop open collector 2 timer
		RLY 1	Start/stop relay 1 timer
		RLY 2	Start/stop relay 2 timer
		START	Start the selected timer output
		STOP	Stop the selected timer output
		STR-STOP	Start or stop the selected timer output

Parameter	Action/Setting Description	Parameter	Action/Setting Description
ALARMFN	Set the function key or digital input to acknowledge an alarm	UNITS	Change the display units within the selected unit class
ACK	Acknowledge all active alarms	DECP	Change the decimal point location
TAREFN	Set the function key or digital input to tare the display	COMMA	Enable or disable the use of a comma on the bottom display
TARE	Tare the display value	ENABLE	Enable comma (default)
RST TARE	Reset the display value	DISABLE	Disable comma
HOLD FN	Set the function key or digital input to hold an output	BARGRAPH	Enable or change the bargraph (PD6604 only)
HOLD OUT	Hold all outputs	PV ( 1 or 2 )	Set the bargraph to display the PV percentage of full scale
HL UNHLD	Hold or un-hold all outputs	OFF	Turn the bargraph feature off
OC 1+2	Hold/un-hold open collector outputs	TOP	Set what to display on the top line
RLY 1+2	Hold/un-hold relay outputs	PV ( 1 or 2 )	Display the process variable
mA OUT	Hold/un-hold 4-20 mA output	PV+UNIT ( 1 or 2 )	Display the process variable and units alternating
HOLD	Hold selected output	PV+TAG ( 1 or 2 )	Display the process variable and tag alternating
HL UNHLD	Hold or un-hold selected output	TAG+UNIT	Display tag and units alternating
DISABLE	Disable function key or digital input	PV+U+TAG ( 1 or 2 )	Display the process variable, unit, and tag alternating
RST FN	Set the function key or digital input to reset a value	PV 1+PV 2	Display both process variables (dual-scale only; see PV 2 under advanced features menu)
RESET	Reset min, max, or max/min PV	TAG	Display the tag
R MINMAX	Reset max and min PV value	OFF	Turn top line off
HINT	Display hint text on key press and execute action on next key press	UNITS	Display the units
OFF	Turn the hint function off	BOTTOM	Set what to display on the bottom line
ON	Turn the hint function on	UNITS	Display the units
SYSTEM	Program system settings	PV ( 1 or 2 )	Display the process variable
ADUTCAL	Calibrate the analog output	PV+UNIT ( 1 or 2 )	Display the process variable and unit alternating
DEFAULT	Reset meter to factory defaults	PV+TAG ( 1 or 2 )	Display the process variable and tag alternating
PV 2	Enable the meter to scale a second PV based on the mA input	TAG+UNIT	Display the tag and unit alternating
DISABLE	Disable dual-scale feature (default)	PV+U+TAG ( 1 or 2 )	Display the process variable, unit, and tag alternating
ENABLE	Enable dual-scale feature	PV 1+PV 2	Display both process variables (dual-scale only; see PV 2 under advanced features menu)
BACKLITE	Enable/disable display backlight	TAG	Display the tag
ENABLE	Enable the backlight (default)	OFF	Turn bottom line off
DISABLE	Disable the backlight	PV PCT ( 1 or 2 )	Display the process variable percentage of max (20 mA)
INFO	View meter software, version, and model; change the identifier tag	mA IN	Display the current mA input value
SFT	The software ID number	mA OUT	Display the current mA output value
VER	The software version		
MODEL	The meter model number		
IDTAG	The meter identifier tag Press <b>Enter</b> to edit tag		
ICAL	Internal calibration used for scaling		
DISPLAY	Program the meter's display		

## Main Menu

The main menu consists of all the meter's programmable functions: *Input*, *Output*, *Advanced*, and *Display*.

- Press **Menu** button to enter *Programming Mode* then press the **Right-Arrow** button to move forward through the menu and the **Up-Arrow** button to move back.
- Press **Menu** at any time to exit and return to *Run Mode*. Changes made to settings prior to pressing **Enter** are not saved.
- Changes to the settings are saved to memory only after pressing **Enter/F3** to confirm the setting or pressing **Enter/F3** at the **SAVE?** screen when available.

**Note:** **BARGRAPH** menu appears in PD6604 menu only.

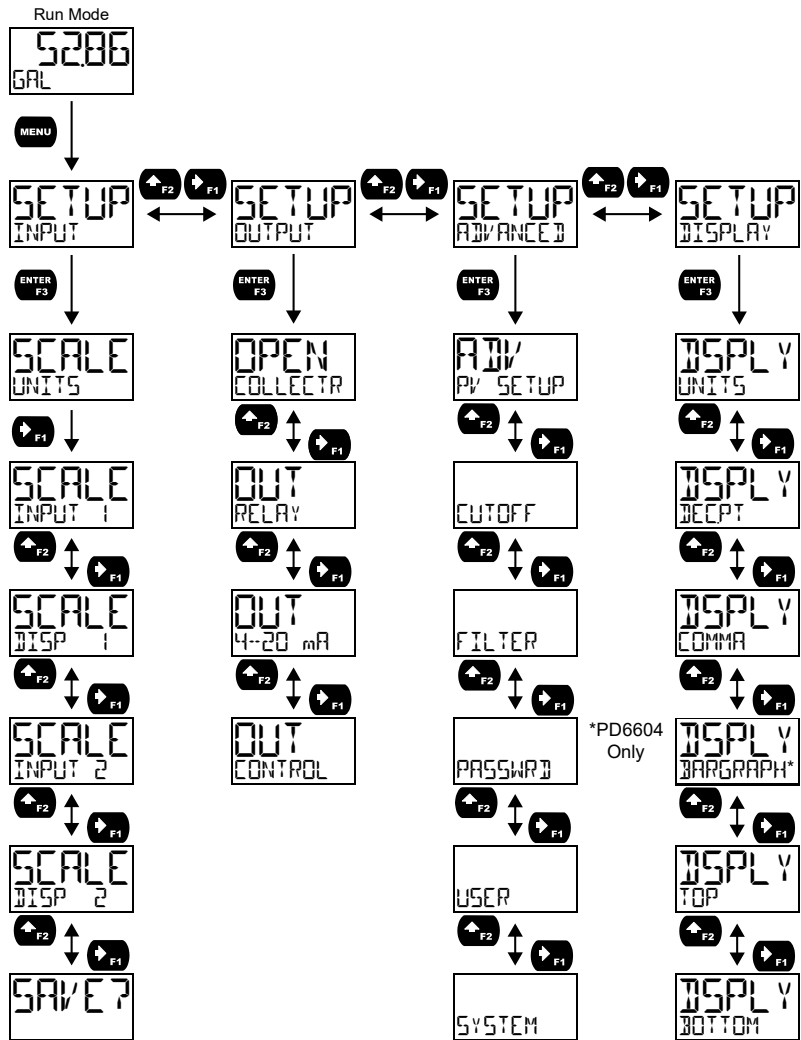

## Setting Numeric Values

The numeric values are set using the **Right** and **Up-Arrow** buttons. Press **Right-Arrow** to select next digit and **Up-Arrow** to increment digit value. The selected digit will flash.

Press and hold **Up-Arrow** to auto-increment the display value. If you have made a mistake or would like to enter a new value, select the left-most digit and press and hold the **Right-Arrow** button until all digits reset to zero.

Press the **Enter** button at any time to accept a setting or **Menu** button to exit without saving changes.

**Note:** the underscore in the graphic below is provided to show which digit would be flashing.

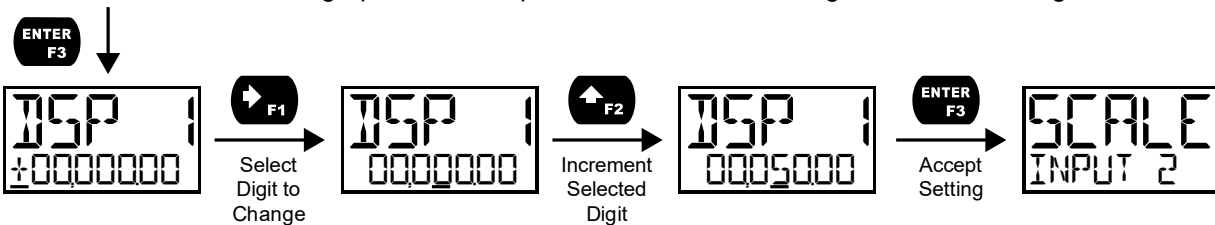



## Setting Up the Input Signal (INPUT)

It is **very important** to read the following information, before proceeding to program the meter:

- The meter is factory calibrated prior to shipment to display 0-100 gallons, which corresponds to the 4-20 mA input. The calibration equipment is certified to NIST standards.
- A calibrated signal source is not needed to scale the meter.
- The PD6602 and PD6604 are single input meters with dual-scale capability.

Enter the *Input* menu to scale the meter to display the 4-20 mA input. The input is capable of accepting any signal from 4 to 20 mA.

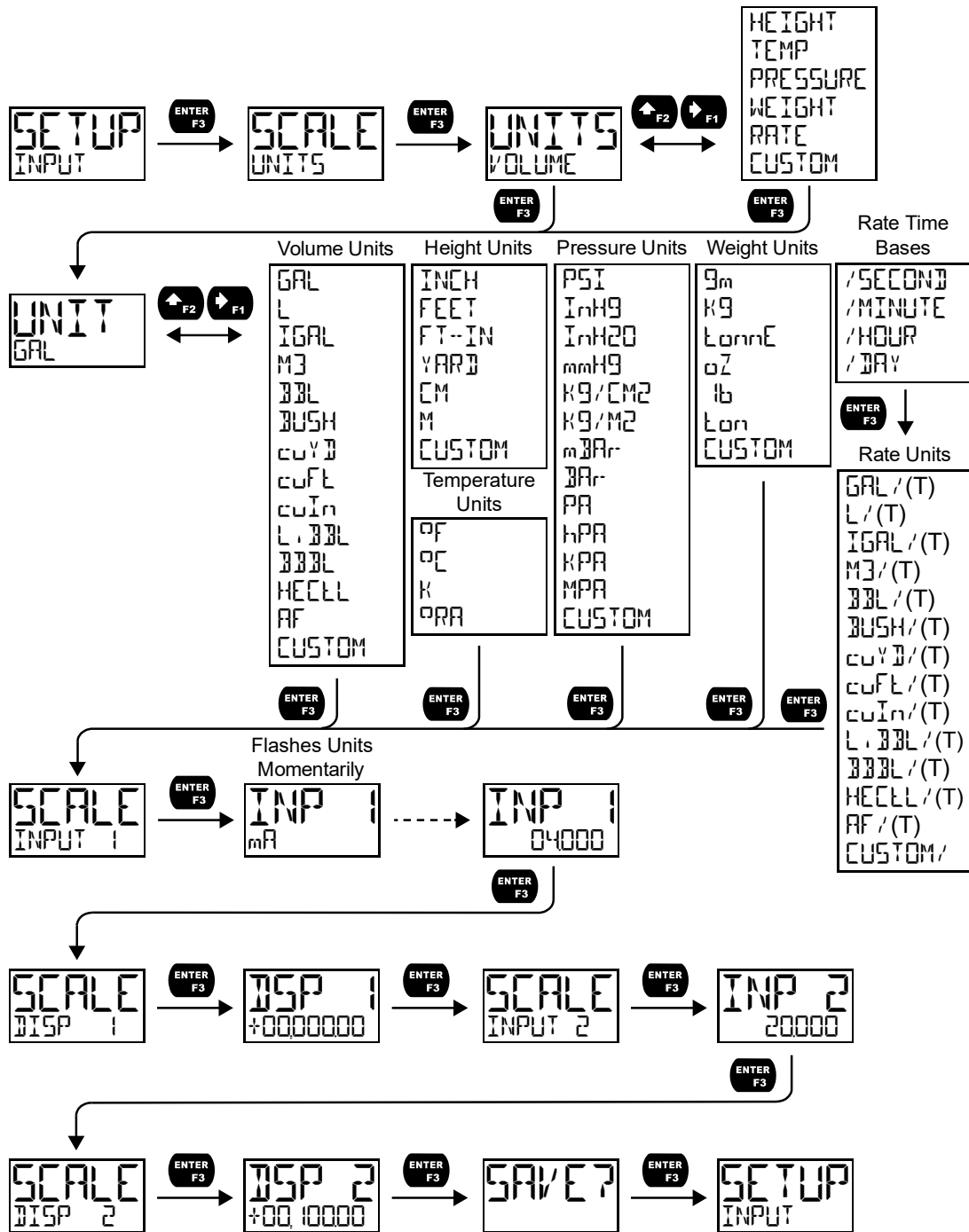

### Available Unit Classes and Units

The meter has six available preprogrammed unit classes, *volume*, *height*, *temperature*, *pressure*, *weight*, and *rate*. Each unit class has the following available units to choose from:

Volume Units (VOLUME)	
GAL	Gallons
L	Liters
IGAL	Imperial Gallons
M3	Cubic Meters
BBL	Barrels
BUSH	Bushels
CUYD	Cubic Yards
CUFE	Cubic Feet
CUIN	Cubic Inches
L.BBL	Liquid barrels
BBBL	Beer barrels
HECEL	Hectoliter
AF	Acre-Foot
CUSTOM	Custom Unit

Height Units (HEIGHT)	
INCH	Inches
FEET	Feet
FT-IN	Feet & Inches
YARD	Yards
CM	Centimeters
M	Meters
CUSTOM	Custom unit

Temperature Units (TEMP)	
°F	Degrees Fahrenheit
°C	Degrees Celsius
K	Kelvin
°RA	Degrees Rankine

Pressure Units (PRESSURE)	
PSI	Pounds per square inch
INHG	Inches of mercury
INH2O	Inches of water
mmHG	Millimeters of mercury
KG/CM2	Kilograms per square centimeter
KG/M2	Kilograms per square meter
mBAR	Millibar
BAR	Bar
PA	Pascal
HPA	Hectopascal
KPA	Kilopascal
MPA	Megapascal
CUSTOM	Custom unit

Weight Units (WEIGHT)	
Gm	Grams
KG	Kilograms
TONNE	Tonnes (metric)
oz	Ounces
lb	Pounds
TON	Tons
CUSTOM	Custom unit

Rate Time Bases (TIME)	
/SECOND	Units per second
/MINUTE	Units per minute
/HOURL	Units per hour
/DAY	Units per day

Rate Units (RATE)	
GAL/(T)	Gallons per time unit (T)
L/(T)	Liters per time unit (T)
IGAL/(T)	Imperial gallons per time unit (T)
M3/(T)	Cubic meters per time unit (T)
BBL/(T)	Barrels per time unit (T)
BUSH/(T)	Bushels per time unit (T)
CUYD/(T)	Cubic Yards per time unit (T)
CUFE/(T)	Cubic Feet per time unit (T)
CUIN/(T)	Cubic Inches per time unit (T)
L.BBL/(T)	Liquid barrels per time unit (T)
BBBL/(T)	Beer barrels per time unit (T)
HECEL/(T)	Hectoliter per time unit (T)
AF/(T)	Acre-Foot per time unit (T)
CUSTOM/(T)	Custom unit per time unit (T)

### Setting Custom Units (CUSTOM)

When the desired unit class or unit of measure within a class is not available, a custom unit may be programmed. Select the CUSTOM menu (or CUSTOM unit within a unit class) in order to enter a custom unit name.

Text values are set using the *Right* and *Up* arrow buttons. Press *Right* arrow to select next character and *Up* arrow to increment character value. The selected character will flash. Press and hold the *Up* or *Right* arrow buttons to auto-increment or decrement the character. Press Enter to accept the character.

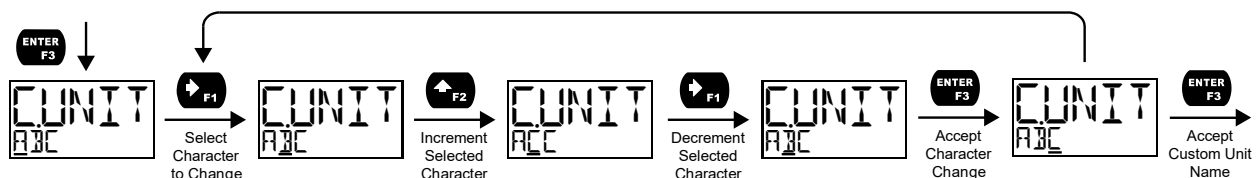

**Notes:**

- Press and hold the Right arrow while no character is being edited to erase all characters to the right of the flashing character
- Press and hold Up or Right arrow to auto-increment or decrement a selected character.

### Scaling the 4-20 mA Input

The 4-20 mA input can be scaled to the appropriate values for a given application. The 4-mA input (input 1) should have a corresponding display value (display 1) which represents the low end of the process value range being measured by the transmitter. Likewise, the 20-mA input (input 2) should have a display value (display 2) which represents the high end of the process value range.

**For example:** If the meter is used to display the level of a 100 ft tall tank, the transmitter should send a 4 mA signal when the tank is empty and a 20-mA signal when the tank is full. The meter should be programmed to interpret these inputs on a display range of 0-100, so that at 4-mA the meter will display 0 and at 20-mA the meter will display 100.

Processes which require a non-linear scale can be accommodated using the linear (LINEAR), exponent (EXPONENT), square root (SQROOT), and round horizontal tank (RH TANK) functions available in the Advanced menu. See Signal Input Conditioning Functions (FUNCTION) on page 33.

A signal source is not needed to scale the meter; simply program the inputs and corresponding display values.

### Setting the Display Features (DISPLAY)

The meter's display functions may be programmed using the *Display* menu. This menu consists of the following submenus: *Units*, *Decimal Point*, *Comma*, *Bargraph* (PD6604 Only), *Top*, and *Bottom*.

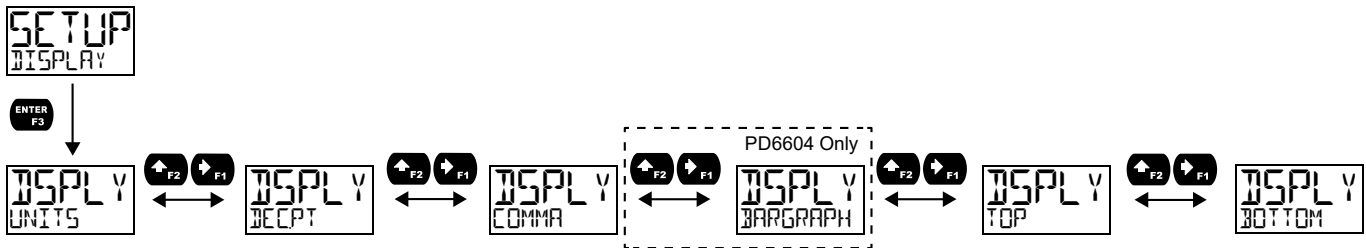

### Changing the Units (UNITS)

It is possible to change the display units within the selected unit class without the need to re-scale the meter. When selecting a new unit from within the DISPLAY menu (e.g. changing from gallons (GAL) to liters (L)), the meter will automatically convert the display values to display the new unit. Enter the UNITS menu, select a new unit of measure from the list of predefined units, and press the **Enter** button. If entering a custom unit (CUSTOM), a custom conversion factor will need to be entered.

### Changing the Decimal Place Location (DECPY)

The decimal point may be set with up to seven decimal places or with no decimal point at all. Pressing the Right arrow moves the decimal point one place to the right until no decimal point is displayed, and then it moves to the leftmost position. Pressing the Up arrow moves the decimal point one place to the left.

If the dual-scale level feature is selected, the decimal point selections for PV1 & PV2 are enabled.

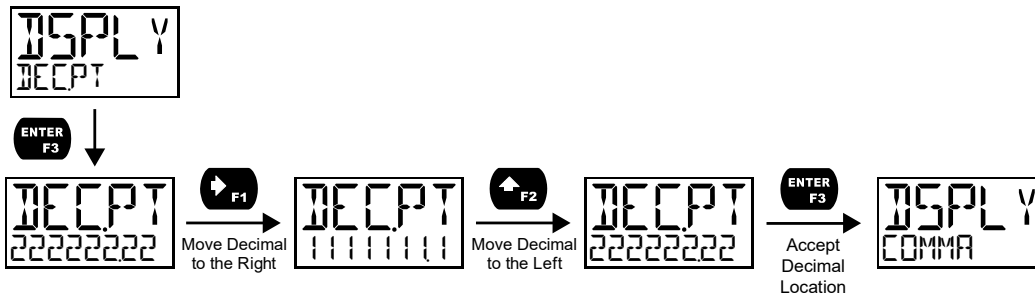

### Enabling or Disabling the Comma on the Bottom Display (COMMA)

The bottom display is set to show a comma separating the thousands and millions place by default if a numeric value is being displayed. This feature can be disabled or enabled using the *Comma* menu.

## Changing What is Displayed (TOP and BOTTOM)

The two display lines (*Top* and *Bottom*) can be programmed to display different values. Use the *Top* and *Bottom* menus to make these changes. Additional menus are available if the meter is in dual-scale mode to allow the second PV to be displayed on either the top or bottom line.

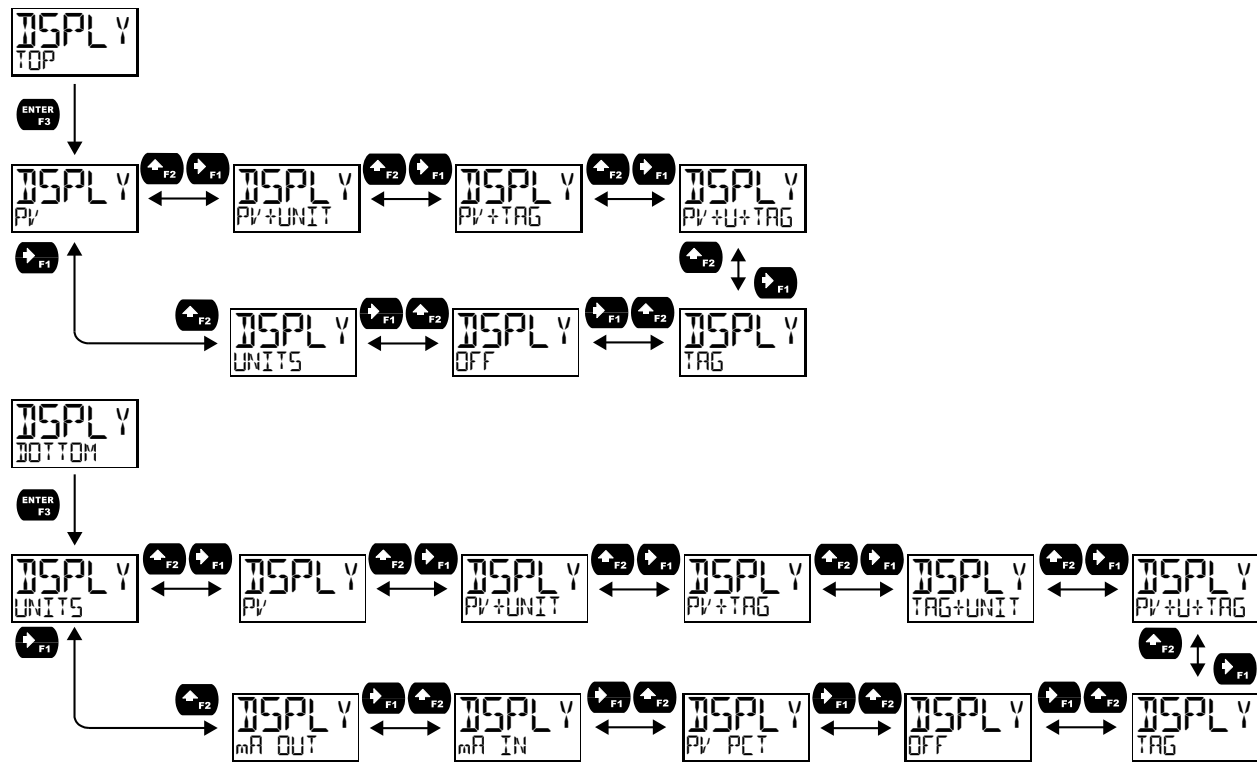

The top display (TOP) can be programmed to display:

1. Process value (PV)
2. Process value 2 (dual-scale only; see PV 2 under advanced features menu)
3. Alternating PV and Units
4. Alternating PV and Tag
5. Alternating PV, Units, and Tag
6. Tag
7. Nothing
8. Units

The bottom display (BOTTOM) can be programmed to display:

1. Units
2. Process Value (PV)
3. Process value 2 (dual-scale only; see PV 2 under advanced features menu)
4. Alternating PV and Units
5. Alternating PV and Tag
6. Alternating Tag and Units
7. Alternating PV, Units, and Tag
8. Tag
9. Nothing
10. PV's Percentage of Full Scale
11. The mA Input
12. The mA Output

### Programming the Bargraph (PD6604 Only)

The PD6604 comes equipped with a bargraph display for applications where a visual representation of the process variable's percentage of full scale is desirable. This feature can be enabled or disabled using the *Bargraph* menu (BARGRAPH). The value displayed on the bargraph can be the percentage of full scale (PV PCT) or the percentage of a user-programmable range (PV). If the meter is in dual-scale mode, the bargraph can be assigned to display either PV1 or PV2 using this menu.

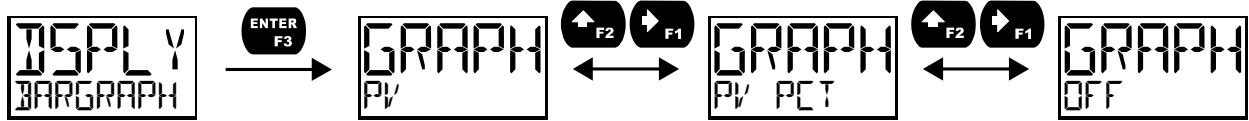

### Programming the Outputs (OUTPUT)

Depending on the purchased model, the meter may be available with two open collector outputs, two solid state relays, and one 4-20 mA output. The *Output* menu will only show options for the available outputs. See Ordering Information on page 4 for details.

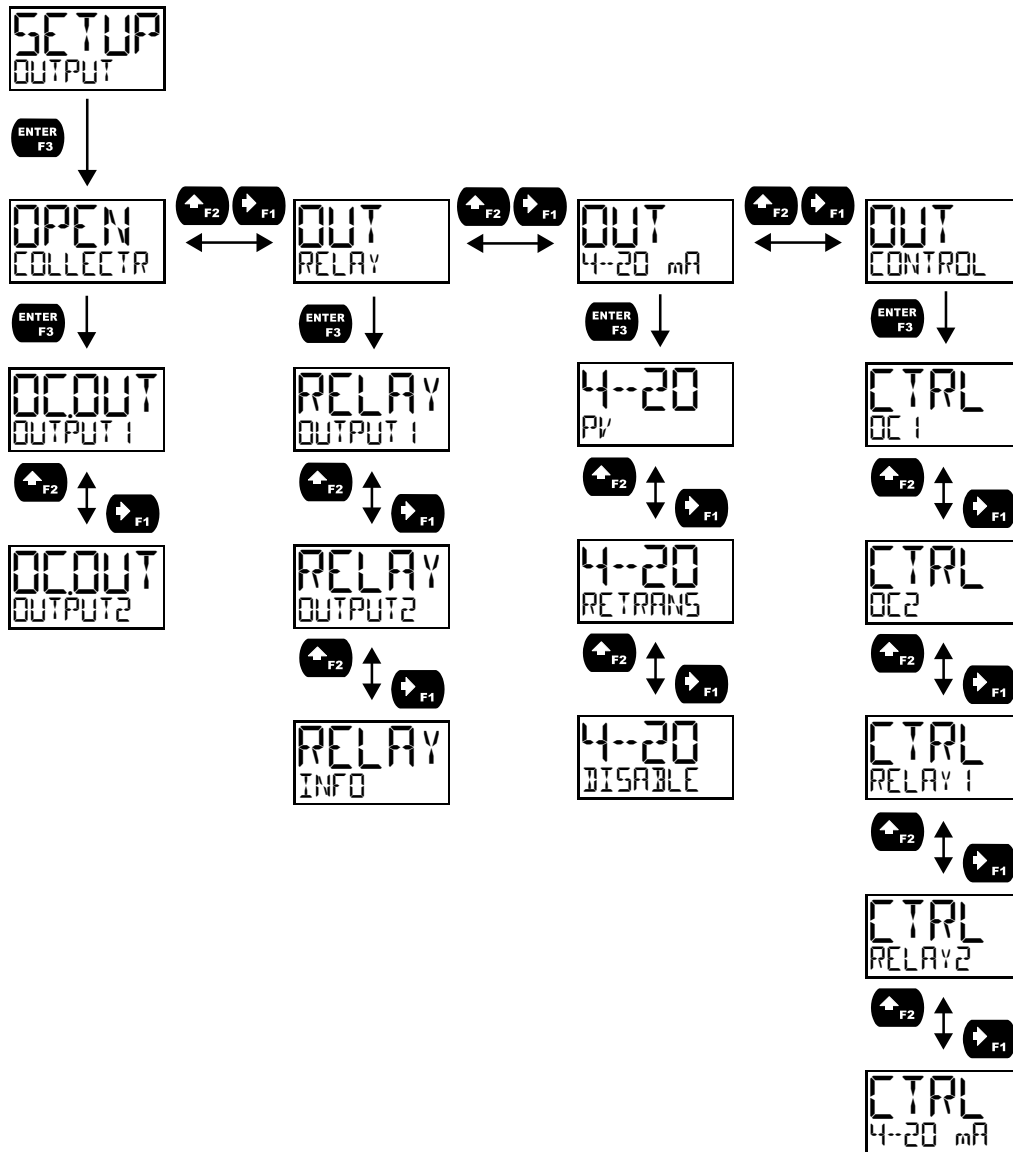

### Open Collector Outputs (OPEN COLLECTR)

The meter is equipped with two NPN open collector outputs that may be set up for pulse outputs, alarms, timed pulses, or turned off.

Pulse outputs can be set to transmit the PV value (PV1 or PV2 if meter is in dual-scale mode). Output 2 may be used to generate a quadrature output based on the other open collector output. An output test mode is also selectable to generate pulses at a constant programmable frequency.

Alarms are available based on the PV value or the digital input. The alarm status will show on the display even if the output is not wired.

A timer output turns the open collector on and off at a specified frequency to act as a timer.

The output may be disabled by selecting `DISABLE`.

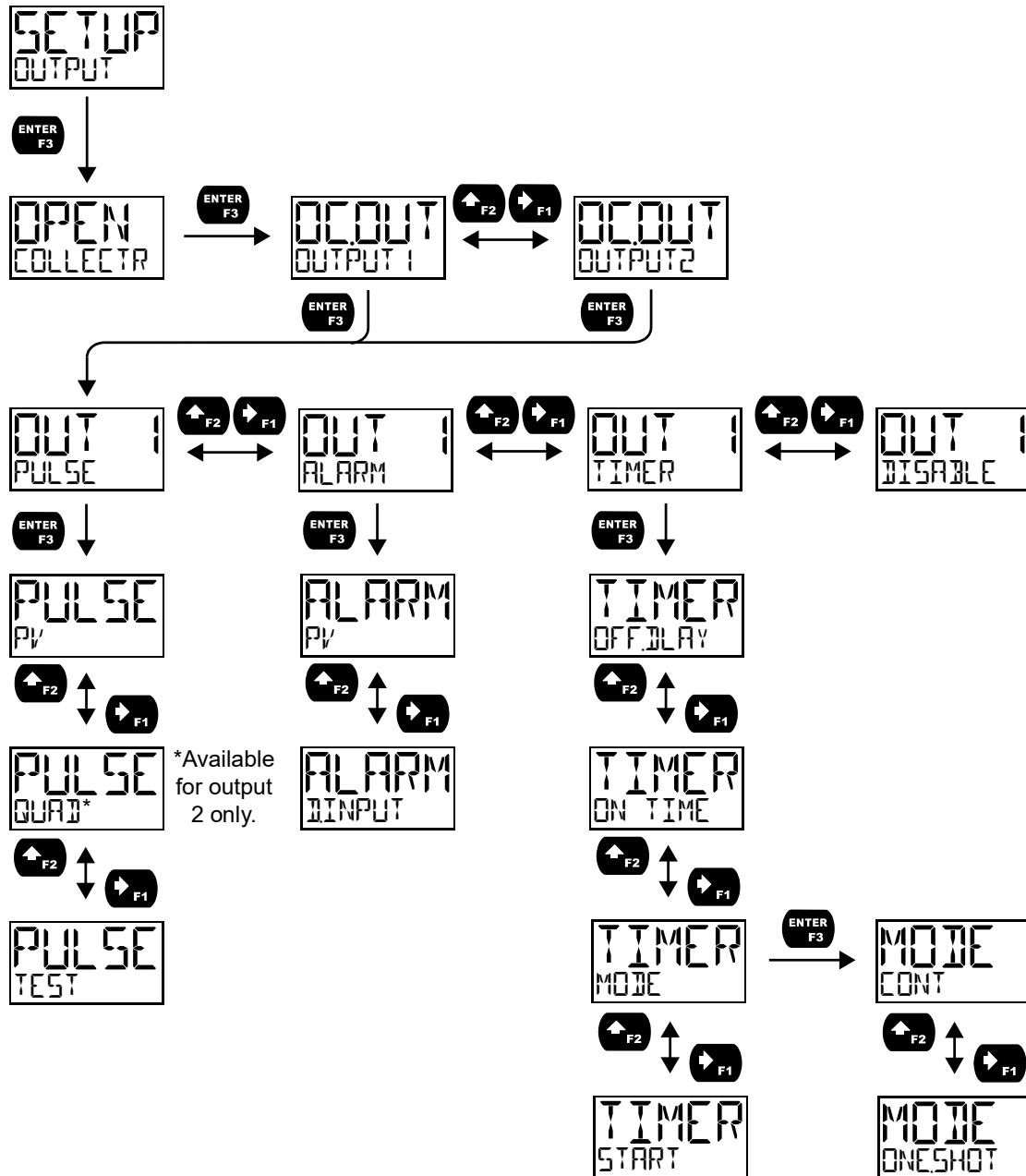

### Pulse (PULSE)

Pulse outputs may be assigned to output the PV at a programmable factor. The factor determines the number of pulses per second which should be generated per unit of measure. For example, if the meter display shows 100 gallons and the factor is set to 2, the number of pulses generated per second would be 200. The maximum frequency is 250 Hz.

Setting output 2 to quadrature will duplicate the other open collector output, but lag by 90 degrees out of phase. The other output should be programmed as desired for the quadrature output function, and must be a pulse (PULSE) output selection. The quadrature maximum frequency for both outputs is 125 Hz.

The TEST option will output a fixed number of pulses per second based on the FREQ value entered.

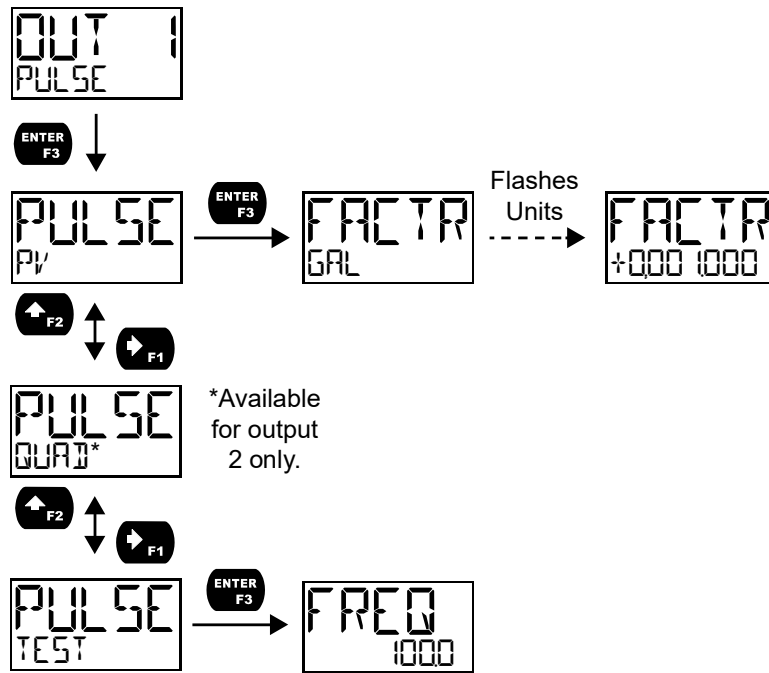

### Alarm (ALARM)

Alarm outputs may be assigned to the PV or the digital input. When assigned to the PV, the alarm may be set as either a high alarm or a low alarm. Alarm actions (AUTO, AUTOMAN, LATCH, L-CLEAR) determine how and when the alarm should be reset. They operate as follows:

- **Automatic (AUTO):** Alarm will reset automatically once the alarm condition has cleared.
- **Automatic/Manual (AUTOMAN):** Alarm will reset automatically once the alarm condition has cleared but can also be reset using the *Enter* button (or whichever function key is set to acknowledge).
- **Latching (LATCH):** Alarm will **not** reset automatically even if the alarm condition is cleared. Press the *Enter* button at any time to clear the alarm.
- **Latching w/ Clear (L-CLEAR):** Alarm will **not** reset automatically. Press the *Enter* button **once the alarm condition has cleared** to reset the alarm.

If the alarm is set to PV, a set and reset point must be programmed. The set point is the display value at which the alarm will turn on and the reset point is the display value at which the alarm will turn off. If the set point is lower than the reset point, the alarm will be a low alarm; if the set point is higher than the reset point, the alarm will be a high alarm. The digital input alarm will trigger whenever the digital input is triggered.

For both the PV and digital input alarms, a delay before the alarm is turned on or off may be set, as well as a failsafe feature which will inverse the on/off programming.

Alarm states will be displayed on the meter even if no open collector output is physically connected. The alarm indicator (!) will display as well as optional red LED backlight, flashing PV value (PV alarm only), and a programmable alarm message.

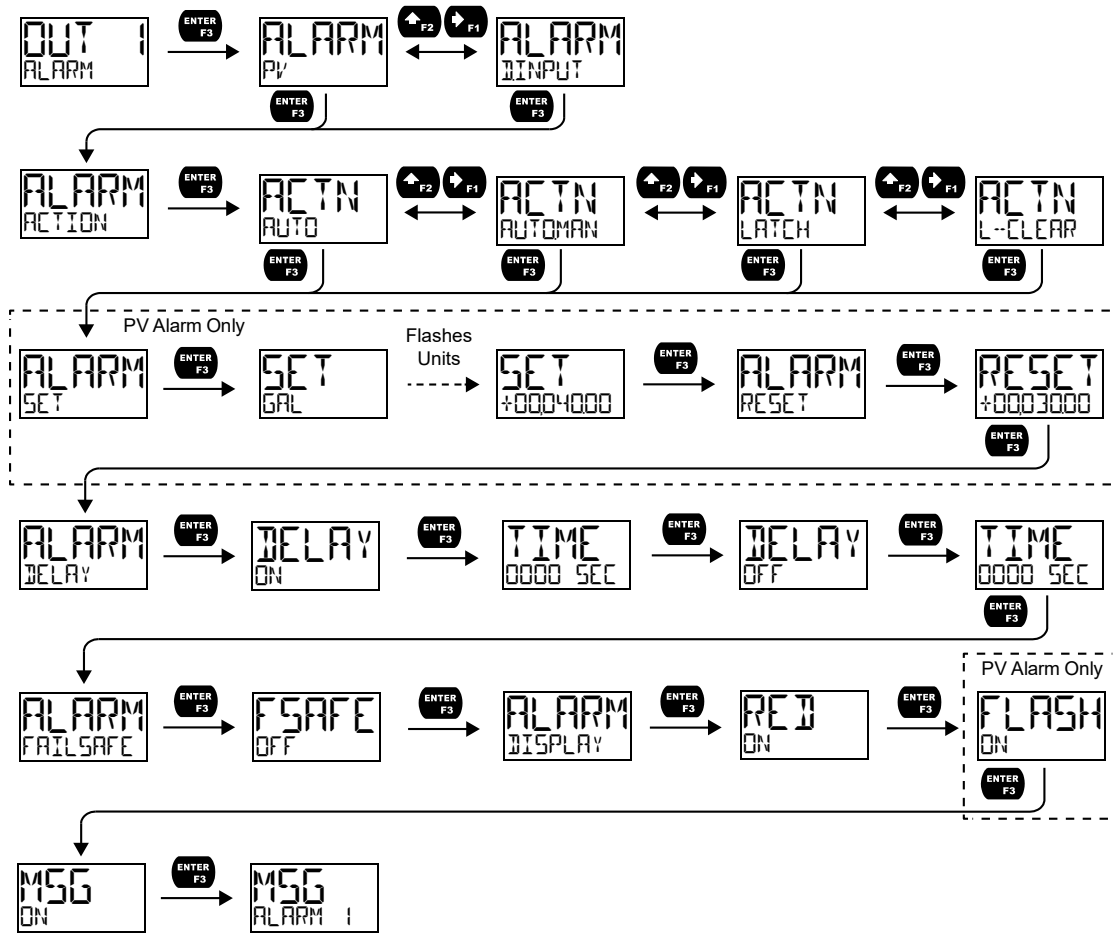

### Timer (TIMER)

The timer output produces a constant width pulse at a constant frequency. Program the *Off Delay* (OFF\_DELAY) from 1 second to 99 hours 59 minutes and 59 seconds. This is the time it takes from selecting START to turning on the output and for how long the output is off in continuous mode. Program the *On Time* (TIME) for the active low pulse from 1 second to 99 hours 59 minutes and 59 seconds (pulse width). This is the period of time for which the output will remain on. The timer output may be set to generate the timed pulse only once (ONESHOT) or continuously (CONT). Select *Start* (START) to begin outputting the constant timed pulse. Select *Stop* (STOP) to end outputting the constant timed pulse. Function keys or the digital input may be assigned to start and stop timer functions (see the USER menu in *Advanced*).

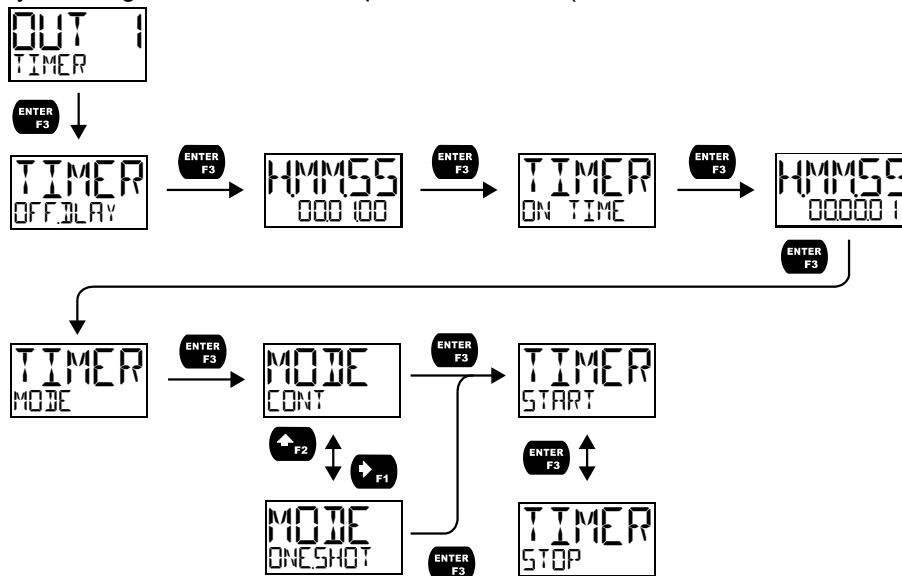



### Solid State Relay Outputs (RELAY)

The meter is optionally equipped with two solid state relays that may be set up for alarms, timer, or pump control. Alternatively, they may be disabled.

Alarms are available based on the PV value or the digital input. The alarm status will show on the display even if the output is not wired.

A timer output turns the relay on and off at a specified frequency to act as a timer.

Pump control allows the relay to turn on and off a pump at specified on and off points. This can be done using only one of the relays to control one pump (ON-OFF), or using both relays in tandem to alternate between two different pumps (ALTERN)

The output may be disabled by selecting **DISABLE**.

**Caution!** *During setup, the relays do not follow the input and they will remain in the state found prior to entering the Relay menu.*

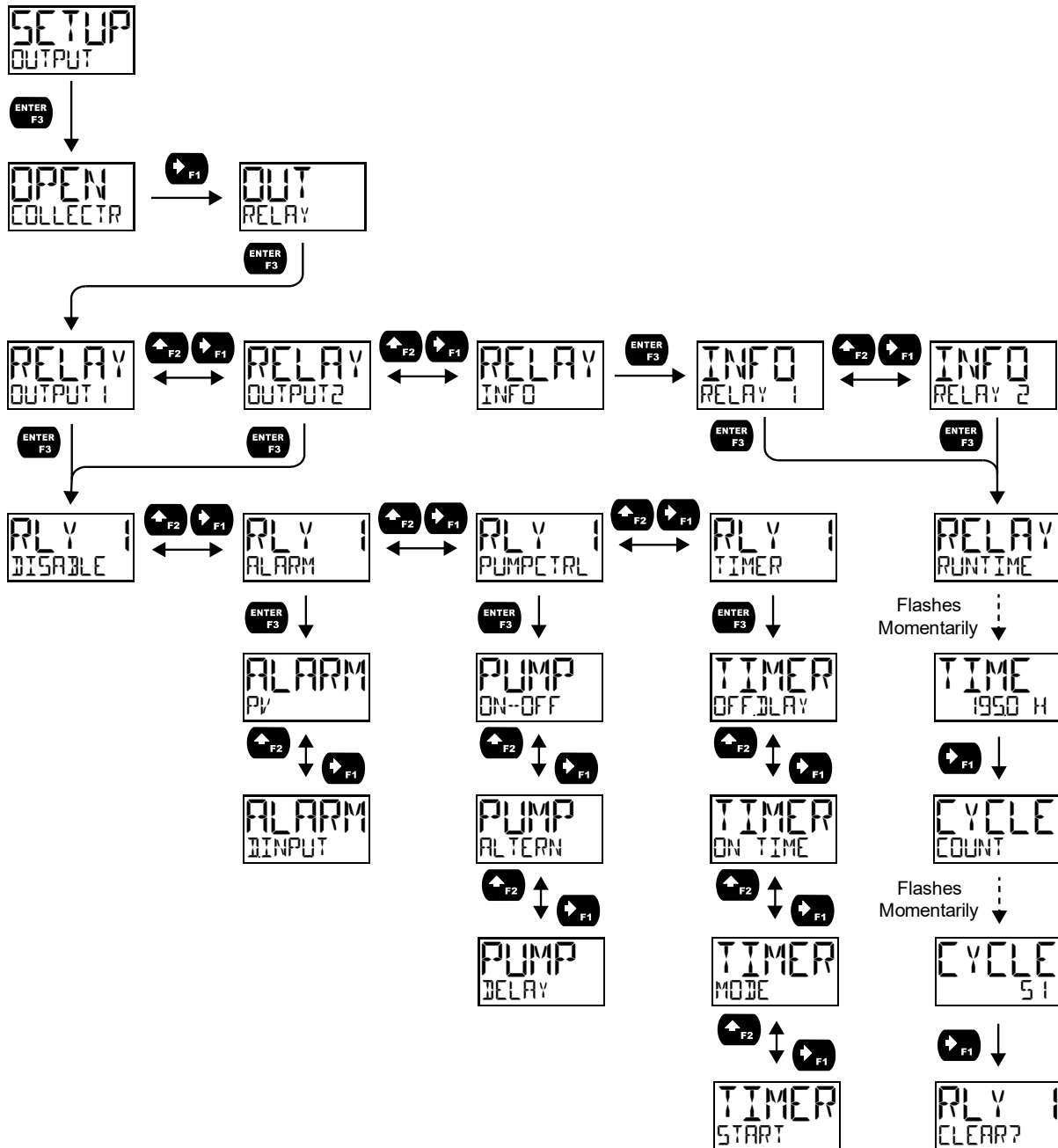

### Alarm (ALARM)

Alarm outputs may be assigned to the PV or the digital input. When assigned to the PV, the alarm may be set as either a high alarm or a low alarm. Alarm actions (AUTO, AUTOMAN, LATCH, L--CLEAR) determine how and when the alarm should be reset. They operate as follows:

- **Automatic (AUTO):** Alarm will reset automatically once the alarm condition has cleared.
- **Automatic/Manual (AUTOMAN):** Alarm will reset automatically once the alarm condition has cleared but can also be reset using the *Enter* button (or whichever function key is set to acknowledge).
- **Latching (LATCH):** Alarm will **not** reset automatically even if the alarm condition is cleared. Press the *Enter* button at any time to clear the alarm.
- **Latching w/ Clear (L--CLEAR):** Alarm will **not** reset automatically. Press the *Enter* button **once the alarm condition has cleared** to reset the alarm.

If the alarm is set to PV, a set and reset point must be programmed. The set point is the display value at which the alarm will turn on and the reset point is the display value at which the alarm will turn off. If the set point is lower than the reset point, the alarm will be a low alarm; if the set point is higher than the reset point, the alarm will be a high alarm. The digital input alarm will trigger whenever the digital input is triggered.

For both the PV and digital input alarms, a delay before the alarm is turned on or off may be set, as well as a failsafe feature which will inverse the on/off programming.

Alarm states will be displayed on the meter even if no relay output is physically connected. The alarm indicator (!) will display as well as optional red LED backlight, flashing PV value (PV alarm only), and a programmable alarm message.

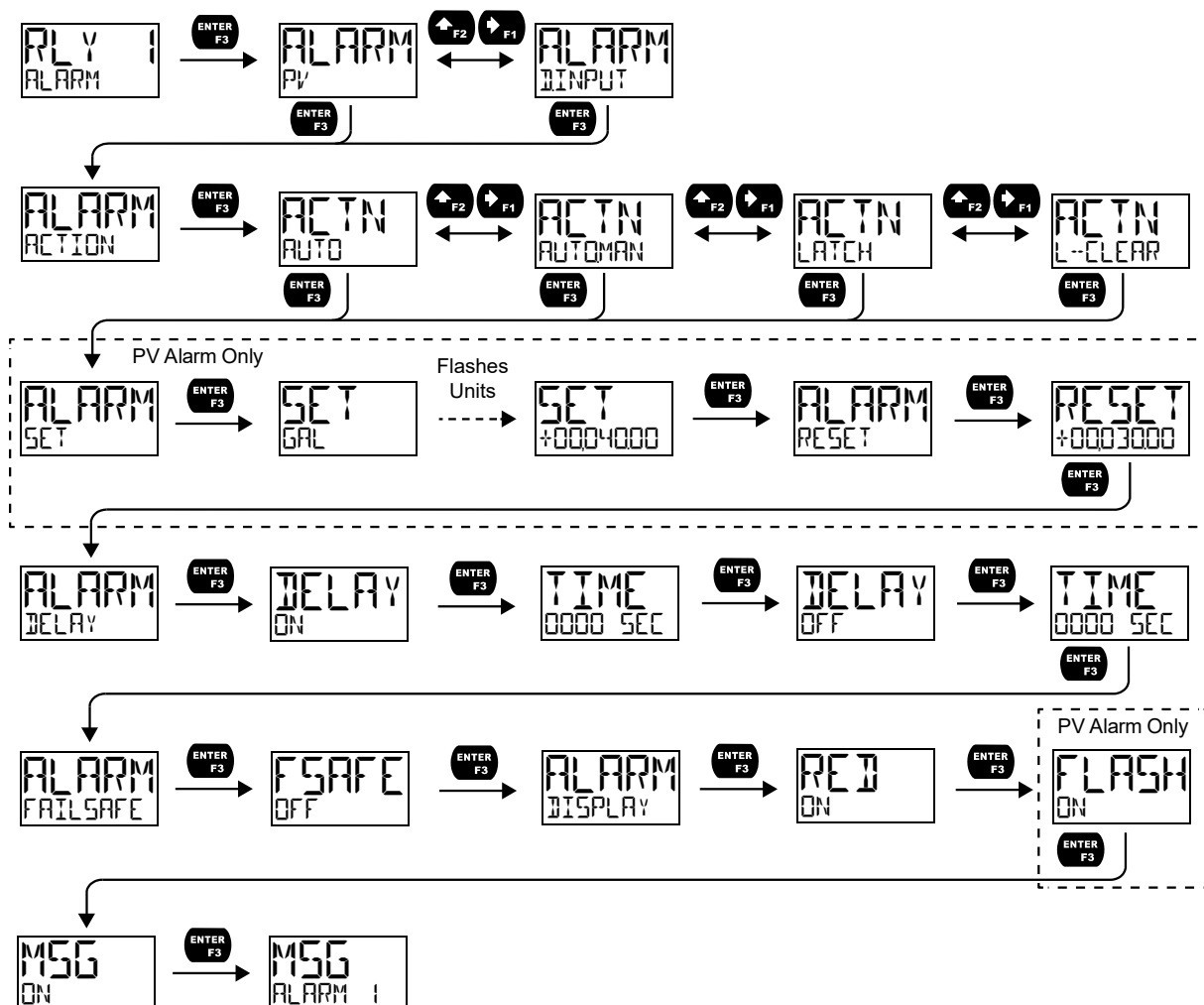

### Pump Control (PUMPCTRL)

The pump control output is used in situations where the relays are used to control pumps. There are two options available for controlling pumps: on-off (ON-OFF) and pump alternation (ALTERN).

ON-OFF will turn the relay on at a programmed *on* point and off at a programmed *off* point. Setting the *on* point higher than the *off* point will make the output activate on a high PV value; setting the *on* point lower than the *off* point will make the output active on a low PV value. The relay will reset automatically.

For pump control applications where two similar pumps are used to control the level of a tank or a well, it is desirable to have the pumps operate alternately. This prevents excessive wear and overheating of one pump over the lack of use of the other pump. Pump alternation uses both relays in tandem to alternate between two similar pumps. The ALTERN menu is only available under Output 1 and will automatically set Output 2 to pump alternation as well. Use the pump *Alternation Time* setting (ALTIME) to control the alternation based on runtime in addition to level cycles.

#### On-OFF (ON-OFF)

When programming a single pump to turn on and off, the *on* and *off* points must be programmed. The relay will activate at the *on* point and deactivate at the *off* point. On and off delays may optionally be programmed in order to delay the activation or deactivation of the relay by a certain number of seconds after reaching either the *on* point or *off* point.

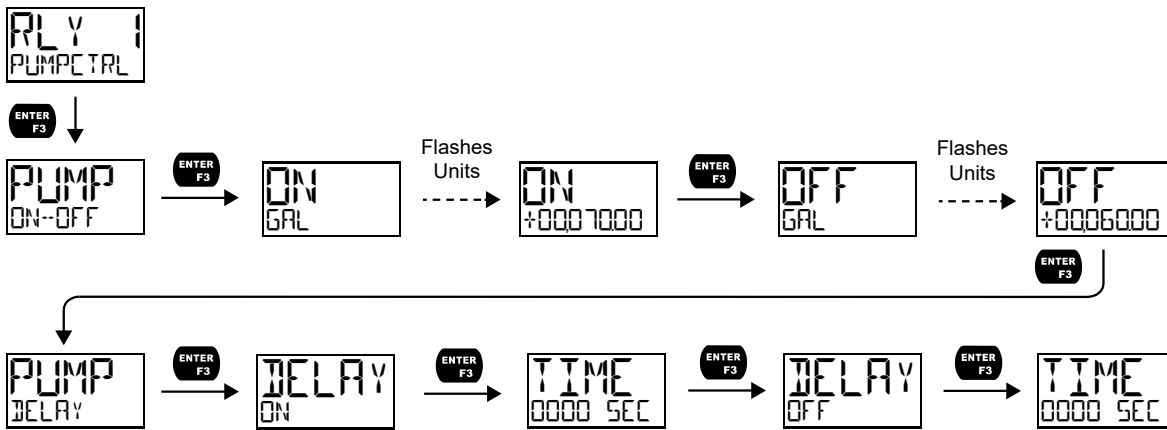

### Pump Alternation (ALTERN)

Pump alternation sets the two relays to alternate every time the first *on* point (ON 1) is reached. The active relay will turn off once the first *off* point (OFF 1) is reached. If the PV reaches the second *on* point (ON 2), the other relay will also turn on. The second relay will turn off once the second *off* point (OFF 2) is reached and the first relay will remain active until the first *off* point (OFF 1) is reached.

On and off delays may optionally be programmed for each *on* and *off* point in order to delay the activation or deactivation of the relays by a certain number of seconds after reaching either the *on* point or *off* point.

For pumps that typically remain on extensively, the alternation time (ALTTIME) parameter sets a period of relay on-time after which the relays should alternate. For example, if the alternation time is set to 1 hour, the active relay will deactivate after 1 hour of runtime and the inactive relay will activate.

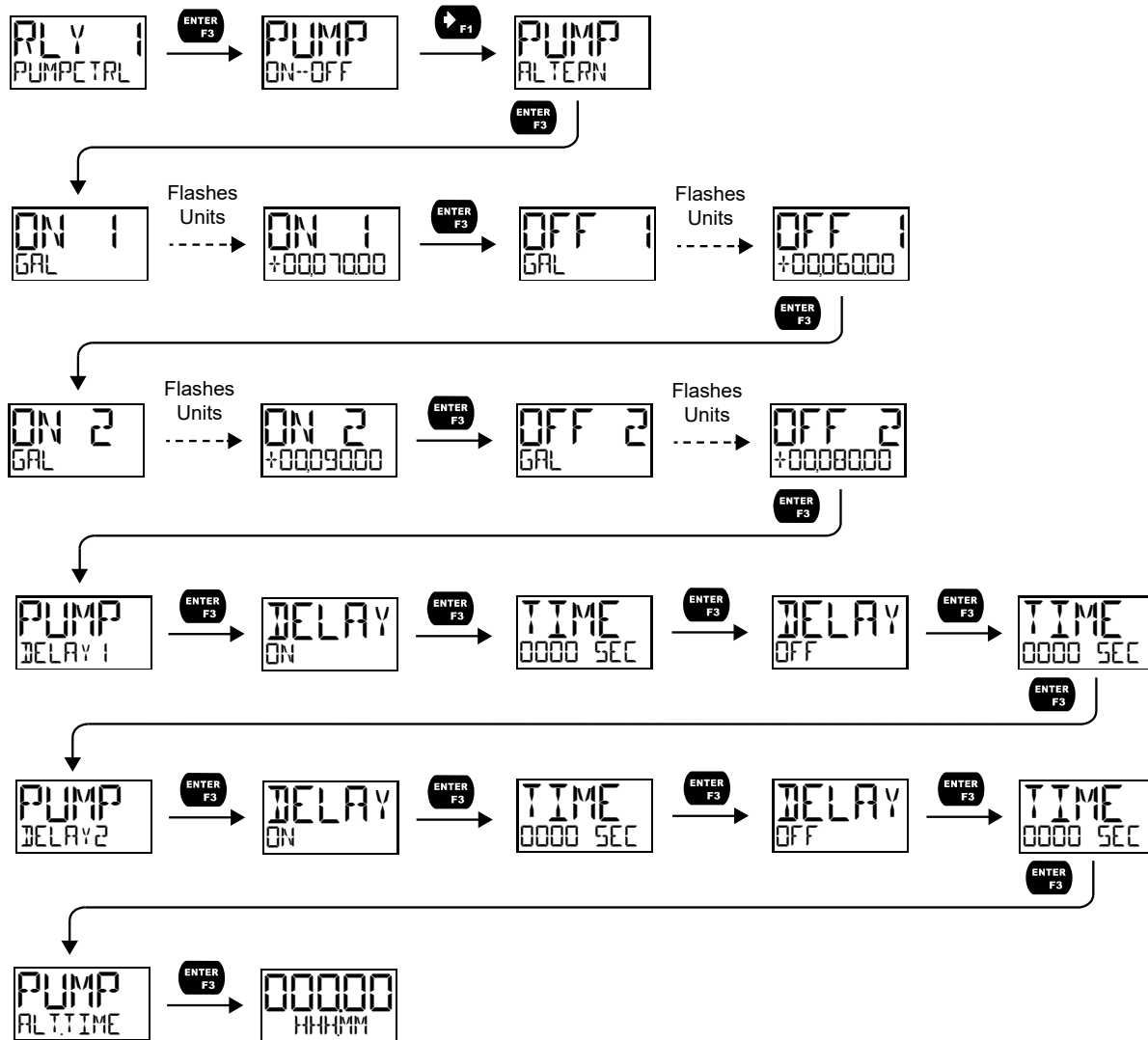

### Pump Alternation Example

The following is an example application where the relays are programmed for pump alternation.

Set and Reset Point Programming			
Relay	On Point	Off Point	Function
1	7000	1000	Controls backup pump
2	6000	1000	Controls main pump

The following graphics provide a visual representation of a typical pump alternation application:

1. Relay #2 turns the main pump on at 6000 gallons and turns it off at 1000 gallons.

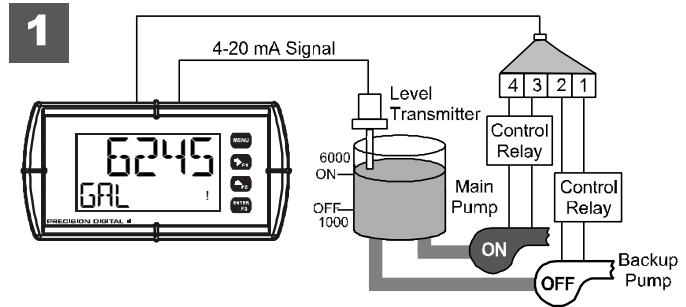

2. With the Pump Alternation feature activated, the next time the level reaches 6000 gallons, relay #1 transfers and starts the backup pump.

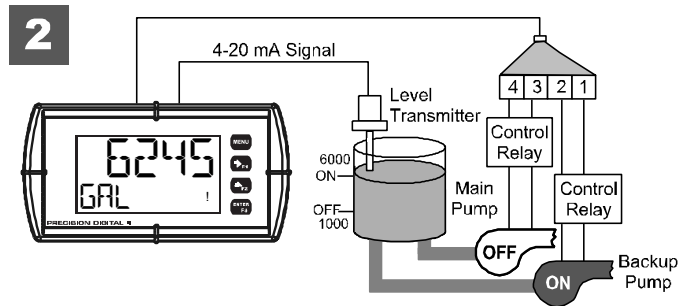

3. If the backup pump is not able to keep up, and the level reaches 7000 gallons, relay #2 transfers and starts the main pump as well.

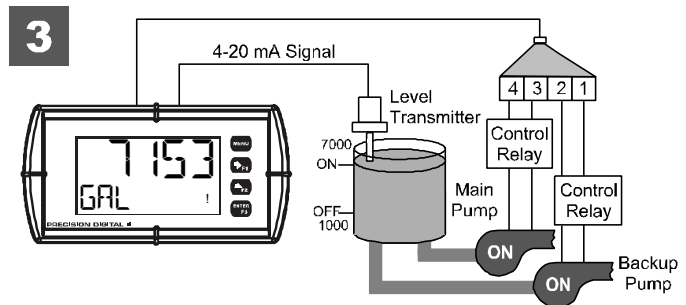

4. Once the level has dropped below the reset points, both relays will turn off.

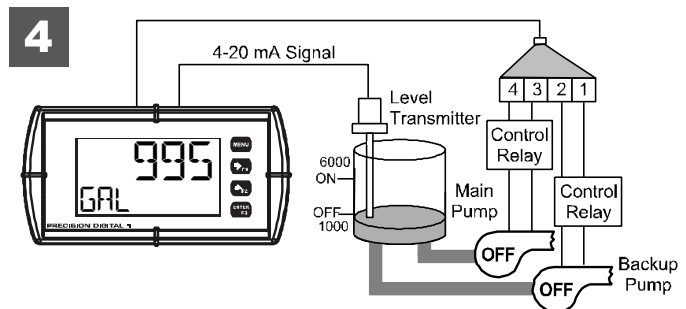

### Timer (TIMER)

The timer output produces a constant width pulse at a constant frequency. Program the *Off Delay* (OFF\_DELAY) from 1 second to 99 hours 59 minutes and 59 seconds. This is the time it takes from selecting START to turning on the output and for how long the output is off in continuous mode. Program the *On Time* (TIME) for the active low pulse from 1 second to 99 hours 59 minutes and 59 seconds (pulse width). This is the period of time for which the output will remain on. The timer output may be set to generate the timed pulse only once (ONESHOT) or continuously (CONT). Select *Start* (START) to begin outputting the constant timed pulse. Select *Stop* (STOP) to end outputting the constant timed pulse. Function keys or the digital input may be assigned to start and stop timer functions (see the USER menu in *Advanced*).

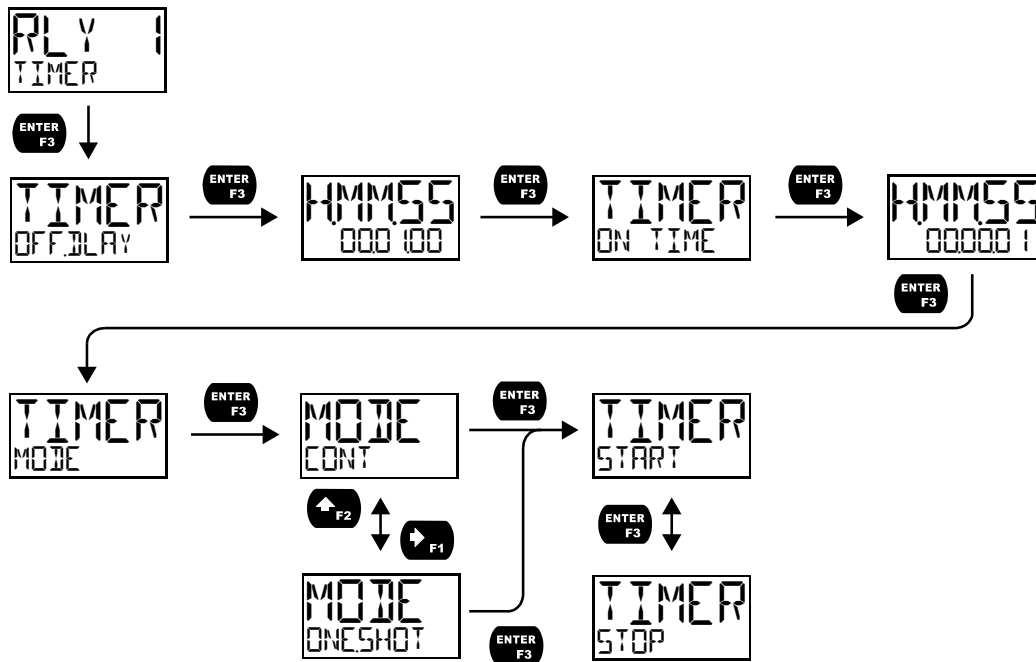

### Relay Information (INFO)

The relay information menu shows run times and cycle counts for each relay. These values may be cleared at any time by selecting the *Clear* option (CLEAR?).

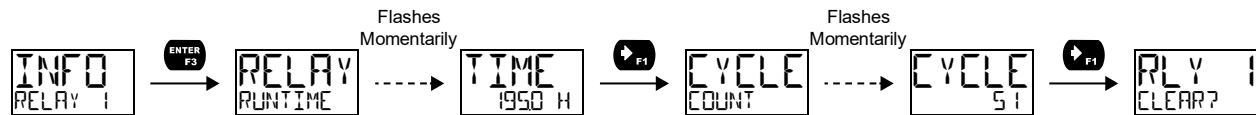

### 4-20 mA Output (4--20 mA)

The 4-20 mA menu is used to scale the 4-20 mA output based on display values. This menu is not present on models without a 4-20 mA output option.

The 4-20 mA analog output (if equipped) can be scaled to provide a 4-20 mA signal for the PV display range or to simply retransmit the 4-20 mA input. The output may be disabled (DISABLE), and will only output the minimum signal.

Overrange and underrange values determine what mA signal the meter will output if the mA input is underrange (<3.5 mA) or overrange (>20.5 mA). This value may be set to 1-mA, 3.5-mA, 3.8-mA, 20.5-mA, 20.8-mA, 23-mA, or disabled.

No equipment is needed to scale the analog output; simply program two display values and corresponding mA output signals.

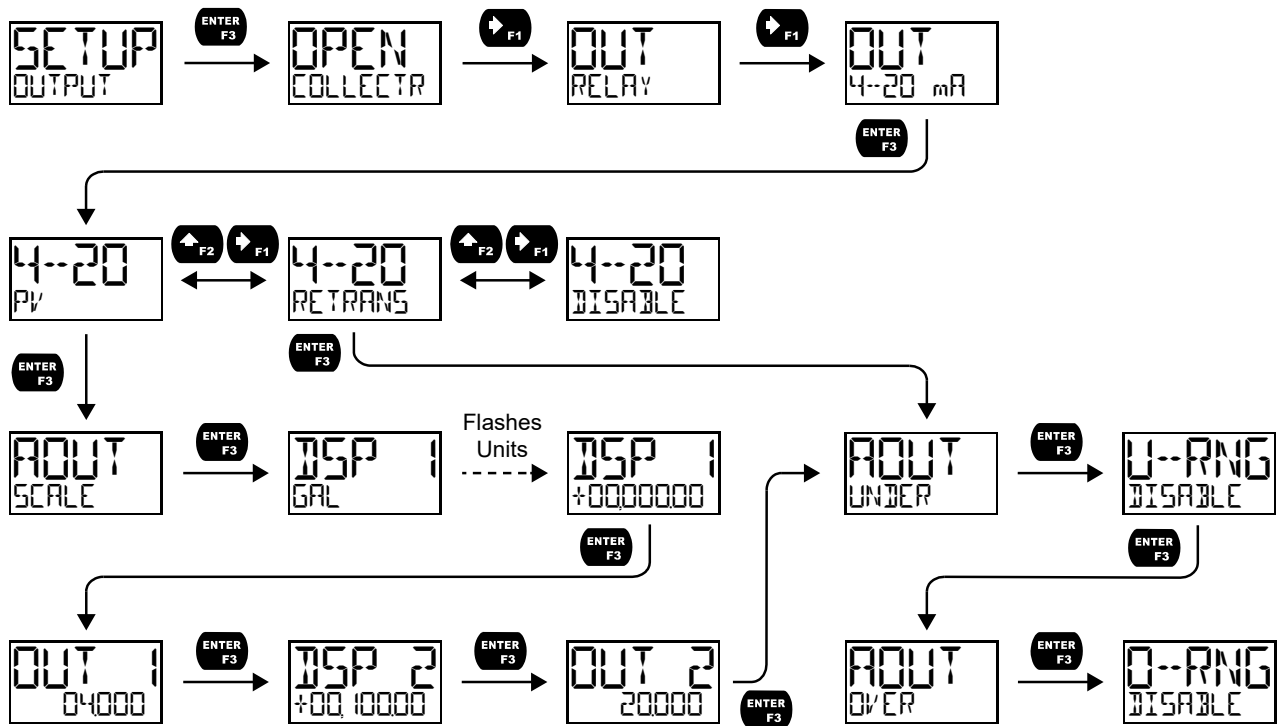

### Process Variable (PV)

To scale the analog output, enter display value 1 and a corresponding analog output value for this display, and enter display value 2 and a corresponding analog output value for this display value. This will provide a linearly scaled analog output.

### Retransmit (RETRANS)

This option will retransmit the 4-20 mA analog input without the need to scale the output.

### Output Control (CONTROL)

The *Control* menu is used to control the open collector outputs, 4-20 mA analog output, or the relays manually, ignoring the input. Each open collector, relay, and analog output can be programmed independently for manual control. Selecting automatic control sets all relays and analog output for automatic operation.

## Advanced Features Menu (ADVANCE)

To simplify the setup process, functions not needed for most applications are located in the *Advanced Features* menu. The options under advanced features include: *advanced PV setup*, *cutoff*, *filter*, *password*, *function key programming*, and *system settings*.

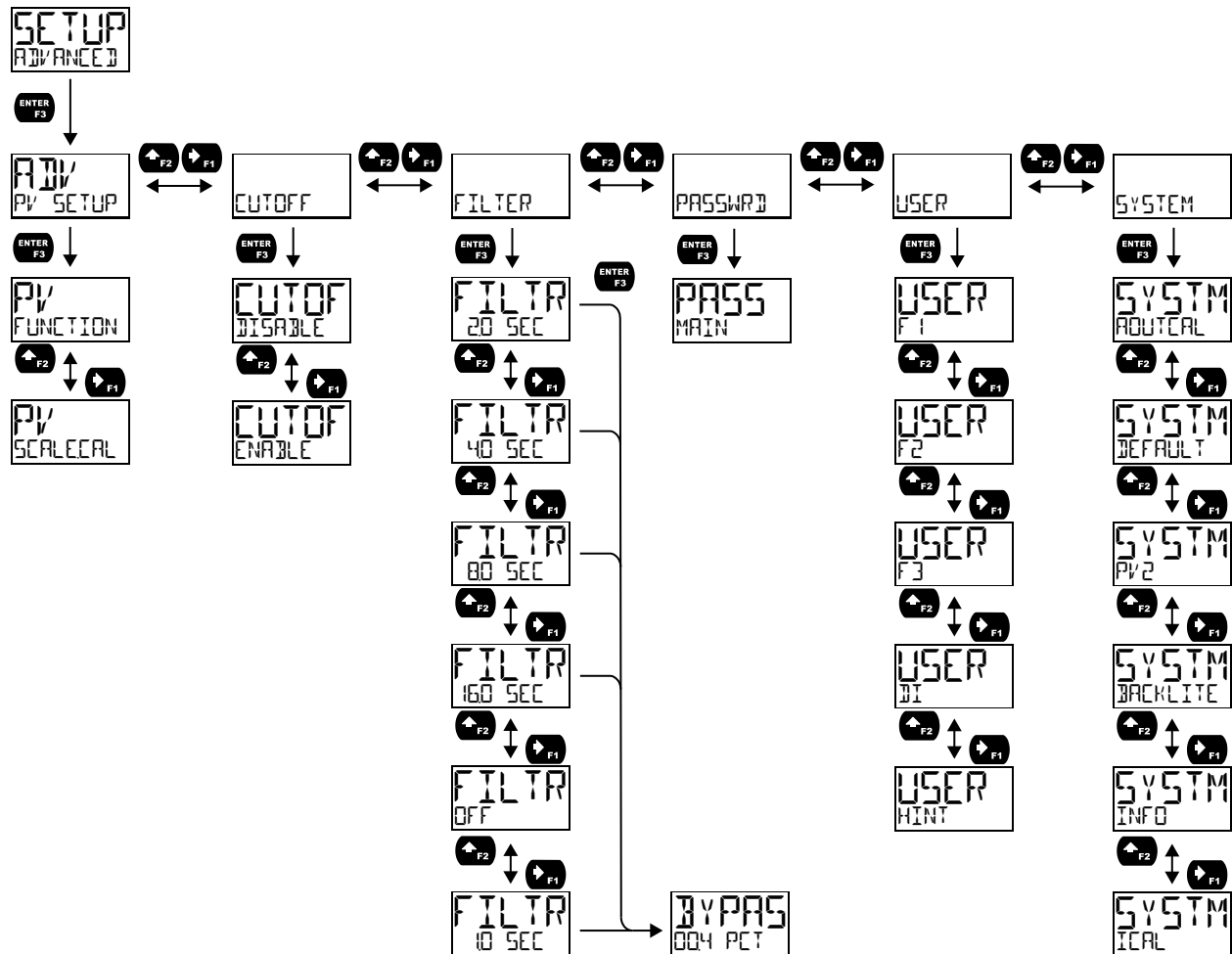



## Advanced Process Variable Setup (ADV PV SETUP)

The Advanced PV Setup menu contains options to apply signal input conditioning functions to the input and scale/calibrate the input signal.

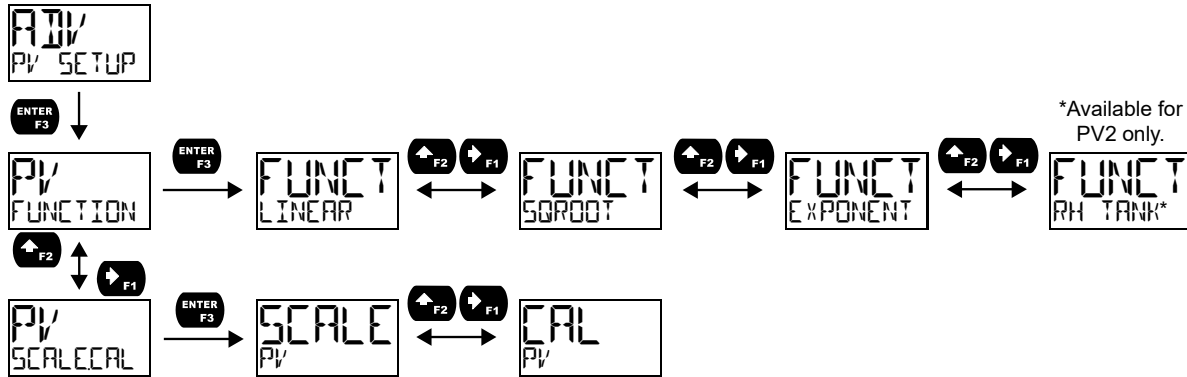

### Signal Input Conditioning Functions (FUNCTION)

The *Function* menu is used to select the signal input conditioner applied to the input: linear, square root, programmable exponent, or round horizontal tank volume calculation. Multi-point linearization is part of the linear function selection.

Meters are set up at the factory for linear function with 2-point linearization. The linear function provides a display that is linear with respect to the input signal.

#### Square Root Linearization (SQROOT)

The square root function can be used to linearize the signal from a differential pressure transmitter and display flow rate in engineering units.

#### Programmable Exponent Linearization (EXPONENT)

The programmable exponent can be used to linearize the signal from level transmitters in open-channel flow applications using weirs and flumes.

#### Multi-Point Linearization (LINEAR)

Meters are set up at the factory for linear function with 2-point linearization. Up to 32 linearization points can be selected for PV1 and PV2 under the linear function. Multi-point linearization can be used to linearize the display for non-linear signals such as those from level transmitters used to measure volume in odd-shaped tanks or to convert level to flow using weirs and flumes with complex exponent. If the dual-scale level feature has been selected, the menus for PV1 & PV2 are enabled.

#### Round Horizontal Tank Linearization (RH TANK)

This function automatically calculates the volume in a round horizontal tank with flat ends. It is only available for PV2 while the meter is in dual-scale mode.

Set the display for the desired decimal point and engineering units before entering the round horizontal tank function. Select units (inches or cm) for the tank dimensions. Enter the diameter and the length in inches or cm and the results will be calculated automatically in US gallons. The unit of measure for the volume can be changed using the display menu. See Changing the Units (UNITS) on page 19 and Available Unit Classes and Units on page 18 for a list of available volume units. There is no need to enter scaling values.

### Advanced Scaling and Calibration (SCALE/CAL)

This menu offers options to scale or calibrate the meter.

#### Scaling the Input (SCALE)

The scale menu in the *Advanced* menu is the same as the scale menu in the *Input* menu. See Setting Up the Input Signal (INPUT) on page 17 for details about scaling the meter.

## Calibrating the Input (CAL)

To scale the meter without a signal source, refer to Setting Up the Input Signal (INPUT), page 17.

The meter can be calibrated to display the process in engineering units by applying the appropriate input signal and following the calibration procedure. The CAL menu should be used with a live signal coming from a 4-20 mA transmitter connected to the process being measured.

During calibration, the mA input value will be displayed as INP 1 and INP 2. Adjust the input source until the desired mA value is shown. The use of a calibrated signal source is strongly recommended.

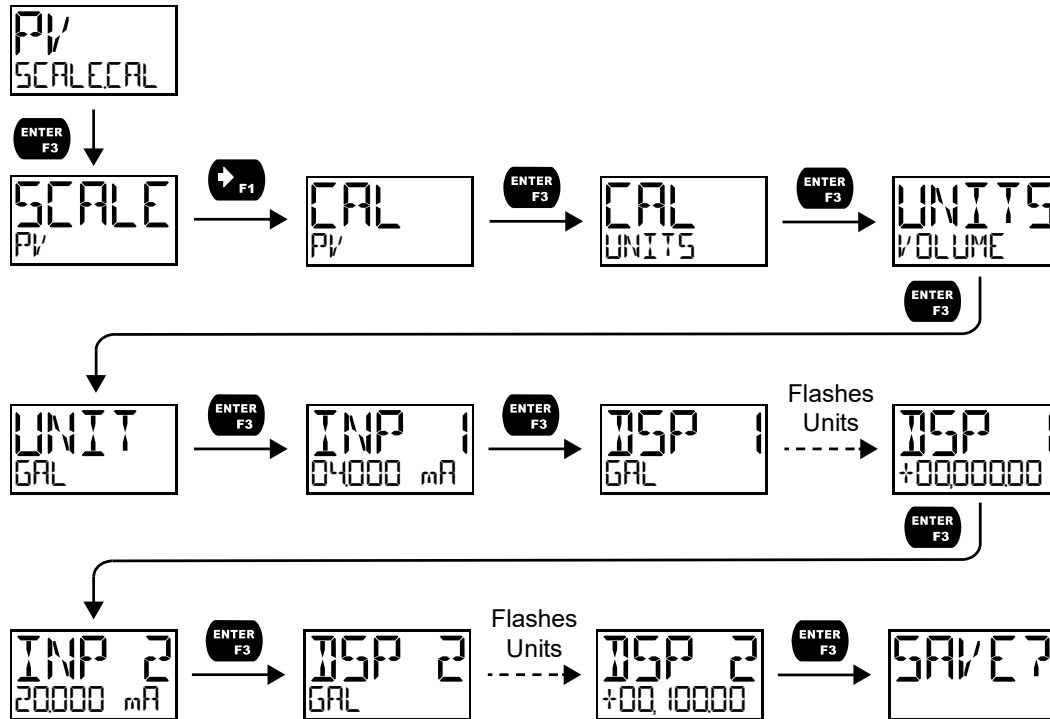

1. After accessing the SCALECAL menu, press the **Right-Arrow** button to scroll to the *Calibration* menu (CAL PV) and press *Enter*.
2. Select the appropriate units for the desired process variable, then press **Enter**. For information on units, see Available Unit Classes and Units on page 18.
3. The meter displays INP 1. Apply a known signal and press **Enter**. The display will flash while accepting the signal.
4. After the signal is accepted, the meter displays DSP 1. Enter a corresponding display value for the signal input, and press **Enter** to accept.
5. The meter displays INP 2. Apply a known signal and press **Enter**. The display will flash while accepting the signal.
6. After the signal is accepted, the meter displays DSP 2. Enter a corresponding display value for the signal input and press **Enter** to accept.
7. After completing calibration, the SAVE ? display will need to be acknowledged using the **Enter** key before calibration will take effect.

### Low-Flow Cutoff (CUTOFF)

The low-flow cutoff feature allows the meter to be programmed so that the often-unsteady output from a differential pressure transmitter at low flow rates always displays zero on the meter. The cutoff value may be programmed from 0 to 999999.9. The meter will display zero below the cutoff value. Programming the cutoff value to zero disables the cutoff feature.

### Noise Filter (FILTER)

The noise filter is available for unusually noisy signals that cause an unstable process variable display. The noise filter averages the input signal over a certain period. The filter level determines the length of time over which the signal is averaged. The filter level can be set between 1 and 16 seconds, or turned off. The higher the filter level, the longer the averaging time and so the longer it takes the display to settle to its final value. Setting the filter level to zero disables the filter function.

### Noise Filter Bypass (BYPASS)

The noise filter bypass changes the behavior of the meter so that small variations in the signal are filtered out but large abrupt changes in the input signal are displayed immediately. The bypass value determines the minimum amount of signal change to be displayed immediately. All signal changes smaller than the bypass value are filtered or averaged by the meter. The noise filter bypass may be set between 0.1 and 99.9% of full scale.

### Enabling Password Protection (PASSWORD)

The *Password* menu is used for programming security to prevent unauthorized changes to the programmed parameter settings.

In order to set a password, enter the *Password* menu and program a five-digit password. When a password has been enabled, the lock icon will display in the lower right of the display.

For instructions on how to program numeric values see *Setting Numeric Values*, page 16.

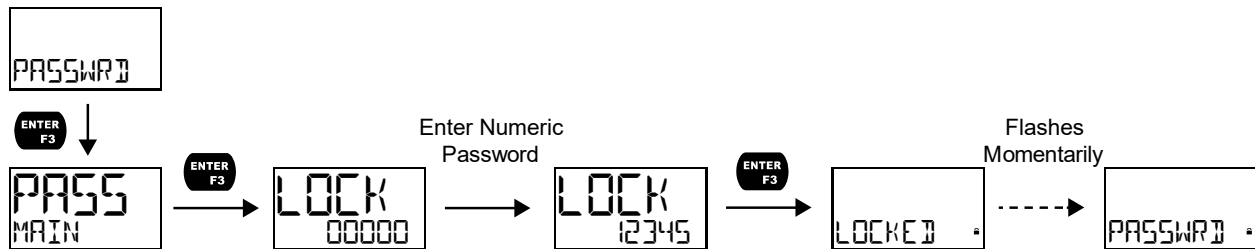

### Making Changes to a Password Protected Meter

If the meter is password protected, the meter will display the message `LOCKED` when the *Menu* button is pressed. Press the *Enter* button while the message is being displayed and enter the correct password to gain access to the menu. After exiting *Programming Mode*, the meter returns to its password protected condition.

### Disabling Password Protection

To disable password protection, access the *Password* menu and clear the entered password either by pressing and holding the *Right Arrow* button until all digits reset to zero or manually changing all of the digits to zero. When the *Enter* button is pressed, the meter will display `UNLOCKED` and will no longer require a password to access *Programming Mode*.

**Note:** If the meter is password protected and the password has been forgotten, the password may be overridden using the master password: **50865**

### Programmable Function Keys User Menu (USER)

The *User* menu allows the user to assign the front panel function keys F1, F2, and F3, and the digital input (a digital input located on the signal input connector) to access some of the menus or to activate certain functions immediately (e.g. reset max & min, hold relay states, etc.). This allows the meter to be greatly customized for use in specialized applications.

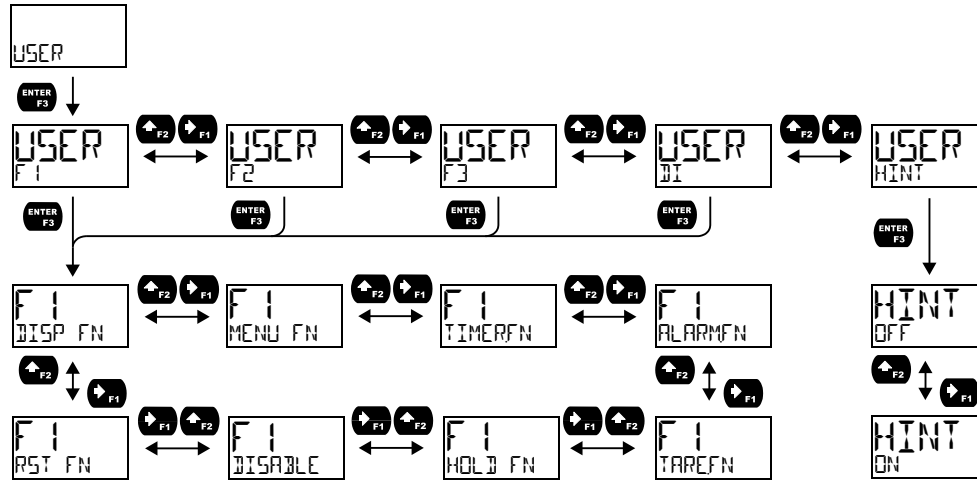

### Function Keys & Digital Input Available Settings

Refer to the following table for descriptions of each available function key or digital input setting.

Display	Description	Display	Description
DISP FN	Set the function key or digital input to display a value	START	Start the selected timer output
DISPLAY	Cycle max, min, and PV(s)	STOP	Stop the selected timer output
DISP PV	Display the PV	STR--STP	Start or stop the selected timer output
PCT PV	Display the PV's percentage of max (20 mA)	ALARMFN	Set the function key or digital input to acknowledge an alarm
UNITS	Display the PV's units	ACK	Acknowledge all active alarms
TAG	Display the PV's tag	TAREFN	Set the function key or digital input to tare the display value
DISPMIN	Display the PV's minimum	TARE	Tare the display value
DISPMAX	Display the PV's maximum	RST TARE	Reset the display value
MIN MAX	Display the PV's minimum and maximum value	HOLD FN	Set the function key or digital input to hold an output
mA IN	Display the mA input value	HOLD OUT	Hold all outputs
mA OUT	Display the mA output value	HL UNHLD	Hold or un-hold all outputs
MENU FN	Set the function key or digital input to access a menu	OC 1+2	Hold/un-hold open collector outputs
RLY INFO	Go to relay information menu (INFO)	RLY 1+2	Hold/un-hold relay outputs
MANCTRL	Go to output control menu (CONTROL)	mA OUT	Hold/un-hold 4-20 mA output
TIMERFN	Set the function key or digital input to start or stop a timer	HOLD	Hold selected output
STARTALL	Start all timers	HL UNHLD	Hold or un-hold selected output
STOPALL	Stop all timers	DISABLE	Disable the function key or digital input
SSTPALL	Start or stop all timers	RST FN	Set the function key or digital input to reset a value
OC 1	Start/stop open collector 1 timer	RESET	Reset min, max, or max/min PV value
OC 2	Start/stop open collector 2 timer	R MINMAX	Reset max and min PV value
RLY 1	Start/stop relay 1 timer		
RLY 2	Start/stop relay 2 timer		

### Enabling the Function Key Hint Feature (HINT)

Enabling the function key hint feature will cause a hint message to be displayed when pressing the F1, F2, or F3 function keys. This text gives a brief description of what the button is programmed to do. Pressing that function key a second time will execute that action.

The hint feature does not affect the digital input (DI) which is intended for immediate execution.

### Changing System Settings (SYSTEM)

The System menu contains the following menus: *Analog Output Calibration, Restore Factory Defaults, Dual-Scale (PV2), Backlight, Information, and Internal Calibration.*

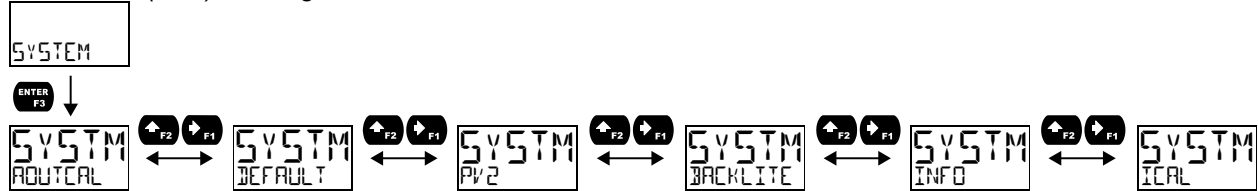

### Analog Output Calibration (ADUTCAL)

To perform the analog output calibration, it is recommended to use a milliamp meter with a resolution of at least 0.1  $\mu$ A to measure the output current. The values saved internally during this procedure are used for scaling the 4-20 mA output in the *Setup* menu.

### Resetting the Meter to Factory Defaults (DEFAULT)

When the parameters have been changed in a way that is difficult to determine what's happening, it might be better to start the setup process from the factory defaults. To load factory defaults, enter the **DEFAULT** menu under the **SYSTEM** menu and press enter twice in quick succession. The meter will load the default settings and restart.

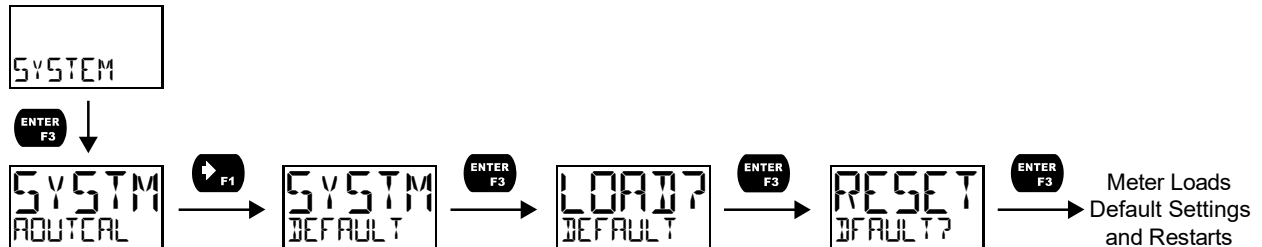

### Enabling the Dual-Scale Feature (PV2)

For some level applications, such as displaying the height and volume of a tank, it is possible to enable a second PV which can be scaled to display a different value based on the same 4-20 mA input. This is accomplished by enabling the dual-scale feature (**PV2**).

When the dual-scale feature is enabled, additional menus will be displayed to allow for the programming of the second PV. The input menu will display PV1 and PV2 for scaling and the display menu will allow both PVs to be displayed on either line, for example. See *Display Functions & Messages* on page 13 for additional information on where additional dual-scale specific menus will appear.

PV2 must be enabled in order to use the Round Horizontal Tank feature. See *Round Horizontal Tank Linearization (RH TANK)* on page 33.

### Enabling or Disabling the Backlight (BACKLITE)

The backlight may be enabled or disabled using the *Backlight* menu. The backlight is enabled by default, but the input must be wired appropriately in order for the backlight to function. See *Current Loop (4-20 mA) Connections* on page 9. The voltage drop is the same if the backlight is not wired or if it is disabled in the software.

### Viewing System Information (INFO)

System information, such as software number, software version, and model number, may be viewed in the **INFO** menu. Press the *Right Arrow* button to cycle through all available meter information. Press *Enter* to go back to the previous menu.

## Calibrating the Internal mA Reference (ICAL)

The meter is factory calibrated prior to shipment to display 0 to 100, which corresponds to the 4-20 mA input. The calibration equipment is certified to NIST standards.

The use of calibrated signal sources is necessary to calibrate the internal source of the meter. The meter's internal source is what allows the user to scale the meter without applying a signal. Check calibration of the meter at least every 12 months.

**Note:** Allow the meter to warm up for at least 15 minutes before performing the internal source calibration procedure.

The *Internal Calibration* menu is part of the *Advanced* menu. Internal Calibration is performed as follows:

1. Press the **Menu** button to enter *Programming Mode*.
2. Press the **Up-Arrow** button **twice** and press **Enter** to access the **Advanced** menu.
3. Press the **Up-Arrow** button and press **Enter** to access the **System** menu.
4. Press the **Up-Arrow** button and press **Enter** to access the **ICAL** menu.
5. The meter displays *low* input current message (4000 mA). Apply a 4-mA signal and press **Enter**. The display flashes for a moment while the meter is accepting the low input signal.
6. After the display stops flashing, the display moves to the *high* input calibration (20000 mA). Apply the high input signal and press **Enter**. The display will flash again while the meter is accepting the high input signal.

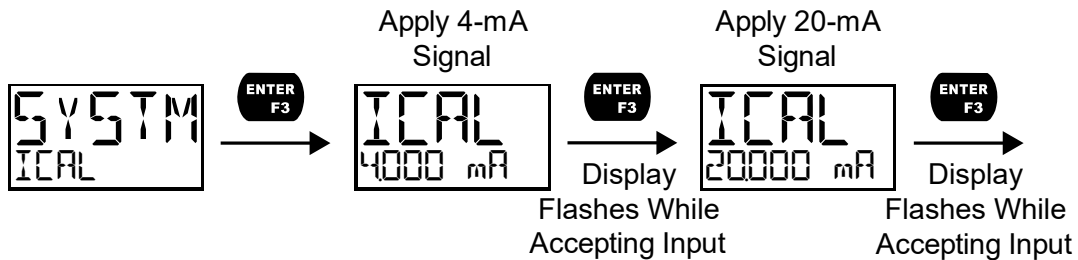





## Meter Operation

The meter is capable of accepting a 4-20 mA current signal and displaying it in engineering units from -99,999 to 999,999 on the top line or from -9,999,999 to 99,999,999 on the bottom line. For example, a 4-20 mA signal could be displayed as -50.000 to 50.000.

The dual-line display can be customized by the user to operate in such a way as to satisfy a specific application. Typically, the top line is used for the process variable while the bottom line is used for engineering units, custom tag, or process variable percentage of full scale.

The 4-20 mA input can be scaled to display the process in two different scales; for example: with *PV2* enabled, the main display could indicate level in feet and the second display could indicate the volume in gallons.

## Front Panel Buttons Operation

Button Symbol	Description
	Press to enter or exit <i>Programming Mode</i> , view settings, or exit max/min readings
	Press to display max/min readings or other parameter/function assigned through the <i>User</i> menu
	Press to reset max/min readings or other parameter/function assigned through the <i>User</i> menu
	Press to acknowledge alarms or other parameters/function assigned through the <i>User</i> menu

## Function Keys Operation

During operation, the programmable function keys operate according to the way they have been programmed in the *Advanced Features – User* menu. The table above shows the factory default settings for F1, F2, and F3.

A hint message may be enabled in order to provide a description of what each function key does prior to executing their assigned function. See Enabling the Function Key Hint Feature (*HINT*) on page 37.

## Digital Input Operation

A digital input is standard on the meter. This digital input is programmed identically to function keys F1, F2, and F3. The input is triggered with a contact closure between DI+ and DI-, or with an active low signal. During operation, the digital input operates according to the way it has been programmed in the *Advanced Features – User* menu.

## Maximum/Minimum Readings

The max & min readings (peak & valley) reached by the process can be displayed either continuously or momentary:

1. Display briefly by pressing the F1 key (default) or assigning to any of the other function keys or to the digital input in the *User* menu.
2. Display continuously by pressing the **Enter** button while the max/min is being displayed to lock the display. Press **Enter** again to unlock.

Any of the F1-F3 function keys (buttons) and the digital input can be programmed to reset the max & min readings. The meters are set at the factory to display the max reading by pressing the *Right Arrow/F1* button and to use the *Up-Arrow/F2* button to access the *Reset* menu. Press the *Right Arrow* button to cycle through the available parameters to reset.

## Changing Engineering Units

It is possible to change the display units within the selected unit class without the need to re-scale the meter. The *UNITS* menu in the *DISPLAY* menu allows the unit of measure to be changed (e.g. from gallons/second (GAL/S) to liters/second (L/S)) and the meter will automatically convert the display values to the new unit of measure. If entering a custom unit (*CUSTOM*), a custom conversion factor will need to be entered. See Changing the Units (*UNITS*) on page 19.

## Troubleshooting

Due to the many features and functions of the meter, it's possible that the setup of the meter does not agree with what an operator expects to see.

If the meter is not working as expected, refer to the recommendations below.

### Reset Meter to Factory Defaults

When the parameters have been changed in a way that is difficult to determine what's happening, it might be better to start the setup process from the factory defaults.

To load factory defaults:

1. Press the **Menu** button to enter *Programming Mode*.
2. Press the **Right Arrow** button **twice** and press **Enter** to access the **Advanced** menu.
3. Press the **Up-Arrow** button and press **Enter** to access the **System** menu.
4. Press the **Right Arrow** button and press **Enter** to access the **Default** menu.
5. Press **Enter** twice in quick succession. The meter will load default settings and restart.

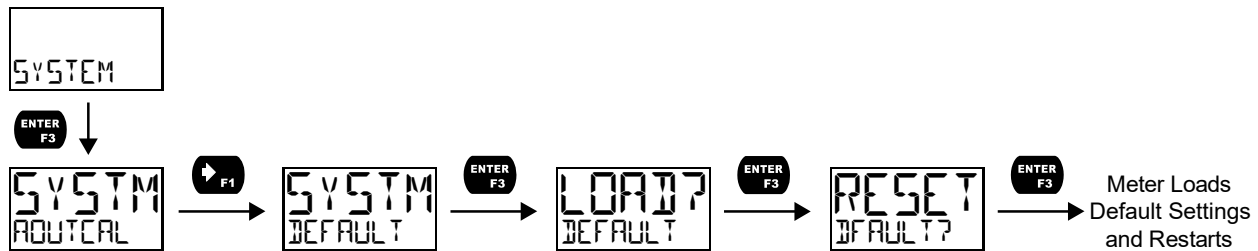

### Determining Software Version

To determine the software version of a meter:

1. Press the **Menu** button to enter *Programming Mode*.
2. Press the **Up-Arrow** button **twice** and press **Enter** to access the **Advanced** menu.
3. Press the **Up-Arrow** button and press **Enter** to access the **System** menu.
4. Press the **Up-Arrow** button **twice** and press **Enter** to access the **Info** menu.
5. Press the **Right-Arrow** button to cycle through the meter information. When done, press the **Menu** button to return to the previous menu.



### Factory Default Settings

The following table shows the factory setting for most of the programmable parameters on the meter.

Parameter	Display	Default Setting
<b>Input Menu</b>		
Unit Class	UNITS	Volume
Unit of Measure	UNIT	Gallons
Input 1	INP 1	4.000 mA
Display 1	DISP 1	0.00
Input 2	INP 2	20.000 mA
Display 2	DISP 2	100.00
<b>Output Menu</b>		
Open Collector Output 1	OUTPUT 1	Disabled
Pulse Factor	FACTOR	1.0
Test Frequency	FREQ	100
Alarm	ALARM	PV
Alarm Action	ACTION	AUTO
Set Point	SET	20.00
Reset Point	RESET	10.00
Alarm On Delay	DELAY ON	0 seconds
Alarm Off Delay	DELAY OFF	0 seconds
Alarm Failsafe	FAILSAFE	OFF
Red LED	RED	ON
Flash PV	FLASH	ON
Alarm Message	MSG	ON
Message Text	MSG EDIT	ALARM 1
Timer Off Delay	OFF DELAY	1 minute
Timer On Time	ON TIME	1 second
Timer Mode	MODE	Continuous
Open Collector Output 2	OUTPUT 2	Disabled
Set Point	SET	40.00
Reset Point	RESET	30.00
Message Text	MSG EDIT	ALARM 2
Relay Output 1	RELAY 1	Disabled
Alarm	ALARM	PV
Alarm Action	ACTION	AUTO
Set Point	SET	70.00
Reset Point	RESET	60.00
Alarm On Delay	DELAY ON	0 seconds
Alarm Off Delay	DELAY OFF	0 seconds
Alarm Failsafe	FAILSAFE	OFF
Red LED	RED	ON
Flash PV	FLASH	ON
Alarm Message	MSG	ON
Message Text	MSG EDIT	ALARM 3

Parameter	Display	Default Setting
Pump Ctrl On	ON	70.00
Pump Ctrl Off	OFF	60.00
Pump Ctrl On Delay	DELAY ON	0 seconds
Pump Ctrl Off Delay	DELAY OFF	0 seconds
Pump Alt On 1	ON 1	70.00
Pump Alt Off 1	OFF 1	60.00
Pump Alt On 2	ON 2	90.00
Pump Alt Off 2	OFF 2	80.00
Pump Alt On Delay 1	DELAY 1 ON	0 seconds
Pump Alt Off Delay 1	DELAY 1 OFF	0 seconds
Pump Alt On Delay 2	DELAY 2 ON	0 seconds
Pump Alt Off Delay 2	DELAY 2 OFF	0 seconds
Timer Off Delay	OFF DELAY	1 minute
Timer On Time	ON TIME	1 second
Timer Mode	MODE	Continuous
Relay Output 2	RELAY 2	Disabled
4-20 mA Output	4-20 mA	PV
<b>Advanced Menu</b>		
Signal Conditioning Function	FUNCTION	Linear (2 pts)
Low Cutoff	CUTOFF	Disabled
Filter	FILTER	2.0 seconds
Filter Bypass	BYPASS	00.4 PCT
Password	PASSWORD	00000
Function Key 1	F 1	Display
Function Key 2	F 2	Reset
Function Key 3	F 3	Acknowledge
Digital Input	DI	Acknowledge
Function Key Hint Feature	HINT	Disabled
Dual-Scale	PV 2	Disabled
Backlight	BACKLIGHT	Enabled
<b>Display Menu</b>		
Unit of Measure	UNITS	Gallons
Decimal Point Location	DECP	2
Comma	COMMA	Enabled
Top Line	TOP	PV
Bottom Line	BOTTOM	Units

## Troubleshooting Tips

Symptom	Check/Action
No display at all	<ol style="list-style-type: none"> <li>1. Check that the 4-20 mA current loop is providing at least 3.5 mA to the meter.</li> <li>2. Check that the voltage drop of all devices connected to the 4-20 mA current loop does not exceed the max rating of the loop power supply.</li> </ol>
Not able to change setup or programming, <b>LOCK</b> is displayed	Meter is password-protected, enter correct five-digit password to unlock.
Meter display flashes: <ol style="list-style-type: none"> <li>1. 999999</li> <li>2. --99999</li> </ol>	Check that the number of digits required for the scaled value does not exceed the maximum digits for the display line. If it does, try adjusting the decimal point location for less precision or changing the PV display to the bottom line.
Display is unstable	Check: <ol style="list-style-type: none"> <li>1. Input signal stability and value.</li> <li>2. Display scaling vs. input signal.</li> <li>3. Filter and bypass values (increase).</li> </ol>
Display response is too slow	Check filter and bypass values
Display reading is not accurate	Check: <ol style="list-style-type: none"> <li>1. Signal input conditioner selected: Linear, square root, etc.</li> <li>2. Scaling or calibration</li> </ol>
Display does not respond to input changes, reading a fixed number	Check display assignment. It might be displaying max, min, or set point.
Display shows: <ol style="list-style-type: none"> <li>1. MAX and a number</li> <li>2. MIN and a number</li> </ol>	Press Menu to exit max/min display readings.
Relay operation is reversed	Check fail-safe settings in <i>Output</i> menu
Relays do not respond to signal	Check: <ol style="list-style-type: none"> <li>1. Relay action in <i>Output</i> menu</li> <li>2. Set and reset points</li> </ol>
If the display locks up or the meter does not respond at all	Cycle the power to reboot the microprocessor.
Other symptoms not described above	Call Technical Support for assistance.

*Note: Certain sequences of events can cause unexpected results. To solve these issues, it is best to start fresh from factory defaults and map changes ahead of time, rather than at random. See Reset Meter to Factory Defaults on page 40 for details on resetting the meter.*

*This Page Intentionally Left Blank*

## How to Contact Precision Digital

- For Technical Support please  
Call: (800) 610-5239 or (508) 655-7300  
Fax: (508) 655-8990  
Email: [support@predig.com](mailto:support@predig.com)
- For Sales Support or to place an order please  
contact your local distributor or  
Call: (800) 343-1001 or (508) 655-7300  
Fax: (508) 655-8990  
Email: [sales@predig.com](mailto:sales@predig.com)
- For the latest version of this manual please visit  
[www.predig.com](http://www.predig.com)

### PRECISION DIGITAL CORPORATION

233 South Street • Hopkinton MA 01748 USA  
Tel (800) 343-1001 • Fax (508) 655-8990



[www.predig.com](http://www.predig.com)