

Mid-West[®] Instrument

MID-WEST INSTRUMENT HAS A FLOW SCALE FOR YOU.



Typical Flow Dial

Flow measurement using Mid-West Instrument differential pressure gauge technology will provide accuracy and reliability you've come to know and trust. Our industrial quality differential pressure flow gauge uses modern materials and current technology to provide an easy to read flow scale.

Mid-West differential pressure flow gauges indicate such flow rates as liters per minute up to gallons per hour, even when used at high line pressures. Units can be supplied with reed switches or relays to initiate alarms, activate other equipment, or shut the system down. Two switches are available when high and low limits are required. 4-20 mA Transmitter also available.

Here are some typical flow designators: **GPM, USGPM, ACFM, SCFM, NM³/HR, LBS/HR, L/MIN, L/SEC, KG/HR, TONS/HR.** Flow scale dials are available for the following Mid-West differential pressure gauges: Model 105, 106, 109, 130, 140 and 142



Model 105/106 Range: 0-10" H₂O to 0-400" H₂O (25 mbar to 1 bar)
Model 109 DP Range: 0-15 PSID (0-1.0 bar) to 0-6000 PSID (0-400 bar)
± 1/2% or ± 1% Full Scale Accuracy
Uni-Directional Dial Ranges are available in either
LINEAR or SQUARE ROOT FLOW SCALES



AVAILABLE FLOW SCALES MODELS: 105, 106, & 109

Uni-Directional Dial Ranges are available in either LINEAR or SQUARE ROOT FLOW SCALES with any appropriate legend (I.E. GPM, SCFM, USGPM, NM3/HR, L/MIN, ETC) at no extra charge			LINEAR Bi-Directional Dials are available with any appropriate Legend at No Charge		
0-0.5	0-30		0-300	1.0-0-1.0	75-0-75
0-1.0	0-35		0-400	2.0-0-2.0	100-0-100
0-1.6	0-40		0-500	5.0-0-5.0	150-0-150
0-2.0	0-50		0-600	10-0-10	200-0-200
0-3.0	0-60		0-700	15-0-15	300-0-300
0-4.0	0-70		0-800	25-0-25	400-0-400
0-5.0	0-75		0-900	30-0-30	750-0-750
0-6.0	0-80		0-1000	50-0-50	1000-0-1000
0-7.0	0-100		0-1500		
0-8.0	0-135		0-1600		
0-10	0-150		0-2000		
0-15	0-160		0-3000		
0-20	0-200		0-4000		
0-25	0-250		0-5000		
			0-6000		



Model 130

Range: 0-5" H2O to 0-400" H2O

0-5" to 0-9.9" H2O ± 5%

0-10" to 0-400" H2O ± 2%

Full Scale Accuracy

Model 140 or 142

142 Range:

0-20" H2O to 0-25 PSID

140 Range:

0-25 PSID to 0-100 PSID

± 2% Full Scale Accuracy

Uni-Directional Dial Ranges are available in either LINEAR or SQUARE ROOT FLOW SCALES

AVAILABLE FLOW SCALES MODELS: 130, 140, 142

Uni-Directional Dial Ranges are available in either LINEAR or SQUARE ROOT FLOW SCALES with any appropriate legend (I.E.GPM, SCFM, USGPM, NM3/HR, L/MIN, ETC) at no extra charge		
Model 130 Flow Dials		Models 140/142 Flow Dials
0-1.0		0-1.0
0-1.25		0-1.5
0-1.5		0-2.0
0-1.75		0-2.5
0-2.0		0-5.0
0-2.5		0-10.0
0-3.0		
0-3.5		
0-4.0		
0-4.5		
0-5.0		
0-5.5		
0-6.0		
0-6.5		
0-7.0		
0-7.5		
0-8.0		
0-8.5		
0-9.0		
0-9.5		
0-10		

Available Multipliers for Flow Dials: X10, X100, X1000, and X10,000

Note: Not all ranges available in all diaphragm materials

MODEL 300

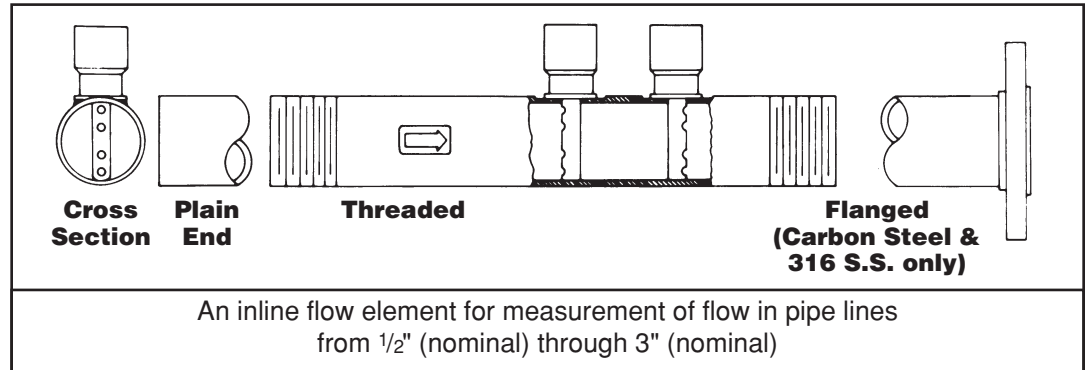

Functions & Applications:

Specifications:

Materials		Carbon Steel (a)		316 Stainless Steel (b)		CPVC Solvent Welded
Pipe Size		1/2", 3/4", 1", 1 1/2", 2", 2 1/2", 3"				1/2", 3/4", 1", 1 1/2", 2", 2 1/2", 3" Schedule 80 only
End Connections		Threaded	Welded	Threaded	Welded	Threaded - Standard Plain End - Optional
Working Pressure (PSIG) Carbon Steel Based on -20 to 600°F 316 S.S. Based on -20 to 200°F CPVC (Water Service) Up to 73.4°F (23°C) For other media and/or temperatures, see Engineering Data.	Pipe Size	Schedule 40	Schedule 40	Schedule 40	Schedule 40	Schedule 80
	1/2	1320	2950	2080	4640	300
	3/4	1130	2400	1770	3770	240
	1	1020	2240	1600	3520	220
	1 1/2	830	1660	1310	2600	170
	2	740	1390	1170	2190	140
	2 1/2	750	1530	1180	2400	150
	3	690	1320	1080	2080	130
NOTES:		For flange applications, see ASME/ANSI B16.5 or Mid-West Bulletin No. ASDE/Latest. (a) Pressures & Temperatures are based on ASTM A53 Grade A Welded Schedule 40 Carbon Steel Pipe. (b) Pressures & Temperatures are based on ASTM A 312 TP 316 Welded Schedule 40 Stainless Steel Pipe. For additional System Pressure (PSIG) vs Temperature (°F) see Mid-West Bulletin No. ASDE/Latest.				
Instrument Connections		1/4" FNPT (Standard), 1/2" (Optional for C.S. or S.S. only)				

Special Features:

Utilizes two averaging flow elements of equal area to sense stagnation (RAM) and static differential pressure providing minimum permanent pressure loss.

Related Products Available:

Indicators & Switches	A broad selection of indicators, with or without switching, are available. For details, please refer to Mid-West Bulletins on Models 105 & 130.
Portable Indicators	A wide variety of portable indicators are also available. Please see Mid-West Bulletin 800/Latest.

Part Numbering System

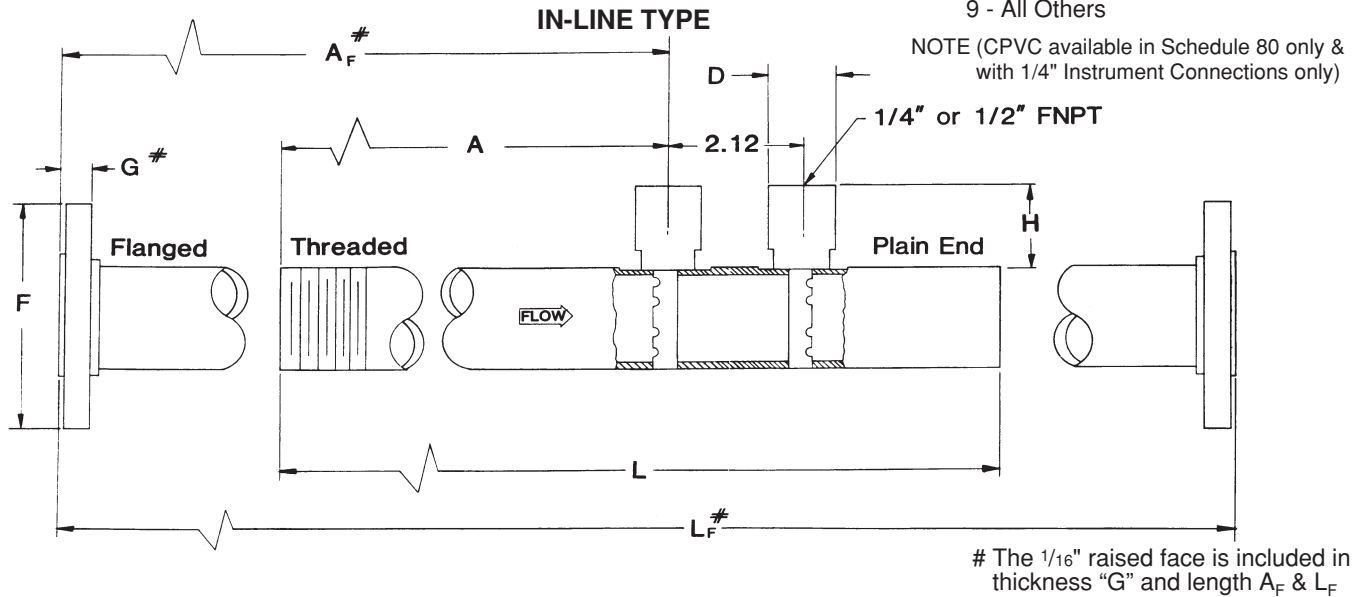
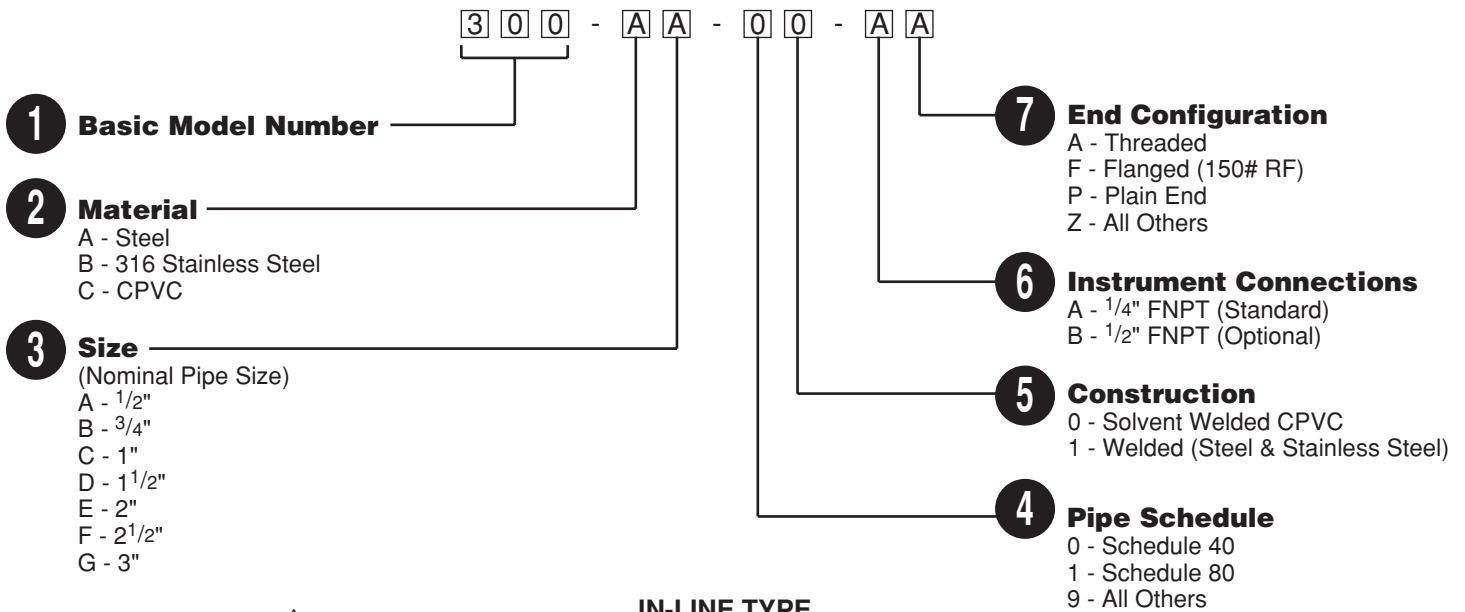

Dimensional Data

Manufacturer reserves the right to change specifications without prior notice.

Pipe Size (Nominal)	L	A	A_F	H	D		F	G	L_F
				(Max.)	1/4" FNPT	1/2" FNPT		Flanged Only*	
1/2"	6"	23/16"	27/16"	1.38			3.5	.44	6.62
3/4"	6"	23/16"	23/8"	1.38			3.88	.50	6.53
1"	8"	311/16"	37/8"	1.38			4.25	.56	8.5
1 1/2"	8"	311/16"	315/16"	1.38	.75	1.12	5.0	.69	8.63
2"	10"	415/16"	51/4"	1.38			6.0	.75	10.75
2 1/2"	10"	415/16"	55/16"	1.38			7.0	.88	10.87
3"	12"	515/16"	65/16"	1.38			7.5	.94	13.0

* Dimensions are for socket weld flanges (150 lb.). For other flange ratings consult factory.

Mid-West®

Instrument

6500 Dobry Dr. □ Sterling Heights, MI 48314
 (586) 254-6500 □ FAX (586) 254-6509
 E-mail: sales@midwestinstrument.com
 Website: www.midwestinstrument.com

REPRESENTED BY