

Mark 695 Series

Piloted Tank Blanketing Regulator 2"

The 2" Mark 695 is an internally piloted tank blanketing regulator.

- Elastomer seals in the form of o-rings are used throughout and are offered as Buna-N, EPDM, and Viton as standard.
- Preformed Jorlon is used for the diaphragm for maximum sensitivity to minute pressure changes inside the tank.
- The outlet ranges are 0.5-4.5 wc and 4-18 wc.
- Operating inlet pressures are determined by set point.
- Lockup is generally less than 0.2" wc.
- An inlet filter w/dripwell is standard to prevent clogging of the bleed orifices in the upper and lower pilot cages.

OPTIONAL FEATURES

- Inlet pressure gauges
- Diagnostic Gauges that register pilot chamber pressure (used when the valve is just about to open or close)
- Combinations of inlet pressure and diagnostic gauges in 0-100 psi and 0-200 psi ranges
- All standard threaded and flanged end connections available
- Standard unit is NACE compatible



SPECIFICATIONS

Sizes: 2" NPS (DN 50)

End Connections:

- 2" Threaded Ends – FNPT or BSPP in an Angled or Straight Thru format
- Flanged – ANSI, DIN JIS
- Others - Socket Weld or Butt Weld

Body Materials

- All wetted parts - Stainless Steel, 316L
- Other Materials Available - Consult Factory

Body Seals: Buna-N, EDPM, Viton & PTFE Gasket

Soft Seat: BUNA-N, EDPM, VITON to match body seals

Diaphragm: Pre-Formed Jorlon

Shut Off: Class VI (ANSI/FCI 70-3-2016)

Weight: 43 lbs (NPT) (19.5kg)

Flow Capacity: Cv (Kv): 10 (8,6), 19 (16,3), 28 (24,1), 48 (41,3)

Sizing Instructions: Use JVCV. All Valves are sized according to API 2000

Maximum Allowable Inlet Pressure: 200 psig max inlet @ 100°F (13,8 bar @ 38°C)

Maximum Operating Inlet Pressure: 200 psig max inlet @ 100°F (13,8 bar @ 38°C)

Set Pressures:

- 0.5 – 4.5 wc (1,25 mb - 11,2 mb)
- 4 – 18 wc (9,96 mb - 44,84 mb)

Maximum Outlet Pressure: 25 psig (1,7 bar)

Pressure @ Maximum Operating Temperature: 200 psi max inlet @ 250°F (13,8 bar @ 121°C)

Maximum Pressure Drop: 200 psig max ΔP (13,8 bar)

Set Point	Maximum Inlet Pressure (Consult Factory for Higher Inlet Pressures)
	2" Size
0.50" - 0.70" w.c. (1,24 - 1,8 mbarg)	100 psig (6,9 bar)
0.7 and up (1,8 mbarg and up)	200 psig (13,8 barg)
Inlet Pressure	
Minimum	25 psig (1,7 barg)
Recommended	≥ 35 psig (2,41 barg)

DIMENSIONS

2" MK695

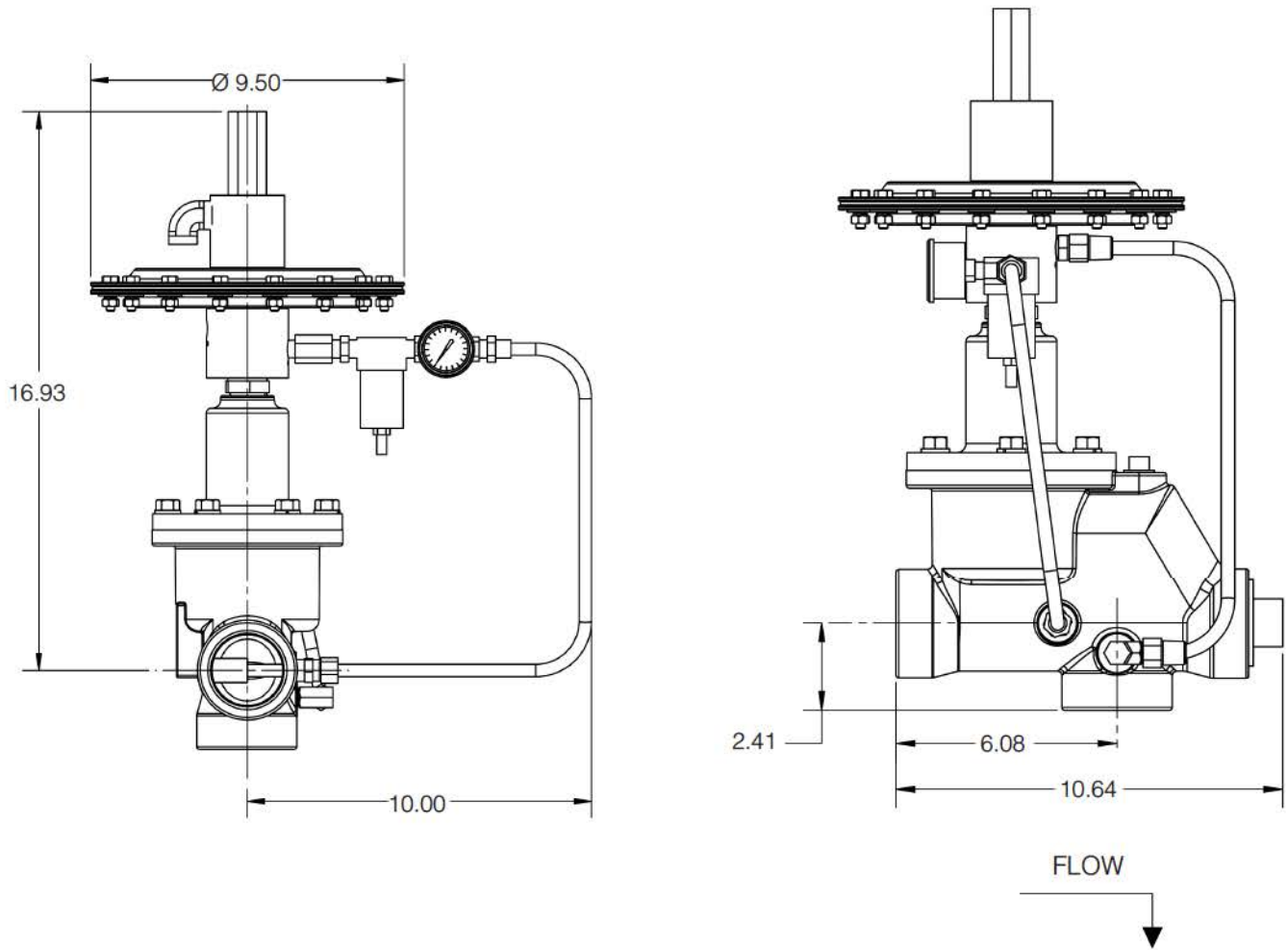

ORDERING SCHEMATIC FOR MK695

Model No	Size	Body Mat'l	1	2	3	4	5	6	7	8	9	10	11	12

Model	
695	Piloted Tank Blanketing Regulator

5 & 6	Cv (Kv)
10	10 Cv (8,6 Kv)
19	19 Cv (16,3 Kv)
28	28 Cv (24,1 Kv)
48	48 Cv (41,3 Kv)

Size	
200	2"

7 & 8	Range
A7	0.5-4.5" W.C.
A8	4-18" W.C.
ZZ	Non-Standard

Body Material	
SB	Stainless Steel (CF3M)
ZZ	Non-Standard

1 & 2	End Connections
PT	NPT
F3	300# Flanged
F5	150# Flanged
ZZ	Non-Standard

9 & 10	Actuator
S1	Standard
ZZ	Non-Standard

3 & 4	Trim Material
BN	Buna-N / 316
VI	Viton / 316
EP	EPDM / 316

11 & 12	Accessory
G1	Inlet Gauge 0 - 100
G2	Inlet Gauge 0 - 200
D1	Diagnostic GA. 0 - 100
D2	Diagnostic GA. 0 - 200
11	Inlet / Diag. Pair 0 -100
22	Inlet / Diag. Pair 0 - 200
IL	In-line Body Option
P1	Purge System
ZZ	Non-Standard

CAUTION: The following information is subject to change. Product Numbers and Description should be checked with the Factory for accuracy before Order Entry.



Jordan Valve a division of Richards Industries
 3170 Wasson Road • Cincinnati, OH 45209
 513.533.5600 • 800.543.7311 • 513.871.0105 (f)
 info@richardsind.com • www.jordanvalve.com