

Mark 5108 Series

Back Pressure Regulating Valves

In many liquid piping systems, it is vital that line pressure is maintained within relatively narrow limits. The Mark 5108 is designed to do just that. The Mark 5108 can act as a back pressure/sustaining valve, bypass pressure control valve, or a surge/relief valve.



OPERATION

BACK PRESSURE/SUSTAINING

Open under normal conditions and closes as upstream pressure falls below set point. Valve allows flow when inlet pressure is above the set-point thus preventing inlet pressure from falling too low. Prevents demand from “robbing” the source, or keeps pump “on its curve.”

BYPASS PRESSURE CONTROL

Opens and modulates to maintain the required pressure. Valve keeps pumping system at a constant pressure by providing back to source. Provides accurate pressure control when system demand varies widely.

SURGE RELIEF

Closed under normal operating pressures. Valve will close when system pressure drops below set point. Protects system from overpressure by exhausting excess pressure. The valve may only have to operate intermittently to prevent pressure surges that might occur on pump start, pump stop or sudden downstream valve closure.

VALVE FEATURES

- Operates automatically off line pressure.
- Inlet pressure is accurate over wide range of flow.
- Inlet Pressure is adjustable with a complete range of control springs.
- Heavy-duty, nylon-reinforced diaphragm.
- Rectangular-shaped, soft seat seal provides drip tight Class VI closure.
- Diaphragm assembly Guided top and bottom.
- Throttling seat retainer for flow and pressure stability.
- Easily maintained without removal from the line.
- Replaceable seat ring.
- Alignment pins assure proper reassembly after maintenance.
- Valves are factory tested.
- Valves are serial numbered and registered to facilitate replacement parts and factory support.



Jordan Valve, a division of Richards Industries
3170 Wasson Road • Cincinnati, OH 45209
513.533.5600 • 800.543.7311 • 513.871.0105 (f)
info@richardsind.com • www.jordanvalve.com

SPECIFICATIONS

Sizes:

Globe Flanged: 1.25" - 24" (32 mm - 600 mm)
 Angle Flanged: 1.25" - 16" (32 mm - 400 mm)
 Glove/ Angle Threaded: 1.25" - 3" (32 mm - 80 mm)
 Globe Angle Grooved: 1.5" - 4" (32 mm - 100 mm)

End Connections:

- Flanged
- Threaded
- Grooved

Temperature Range:

(Valve Elastomers)
 Buna-N: -20°F to 180°F (-29°C to 82°C)
 Viton: 20°F to 230°F (7°C to 110°C)
 Fluorisilicon: -40°F to 150°F (-40°C to 66°C)
 EPDM: 0°F to 230°F (-18°C to 110°C)

Spring Ranges: (inlet setting)

5-30 psi (0,34 - 2,07 bar)
 20-80 psi (1,38 - 5,52 bar)
 65-180 psi (4,48 - 12,41 bar)
 100-300 psi (6,89 - 20,68 bar)

Materials:

Body/Bonnet: Ductile Iron (epoxy coated), Carbon steel (epoxy coated), Stainless Steel, B61 bronze, Ni-Al-Bronze, Duplex Stainless Steel, Monel

Seat Ring: Bronze B61, Stainless Steel, Optional: Ni-Al-Bronze, Duplex Stainless Steel, Monel

Stem: Stainless Steel, Monel, Optional: Duplex Stainless Steel

Spring: Stainless Steel, Optional: Inconel

Diaphragm: Buna-N Nylon Reinforced, Viton, EPDM

Seat Disc: Buna-N, Viton, EPDM

Pilot: Bronze, Stainless Steel (Other pilot system components: Bronze/Brass, All Stainless Steel) Optional: Ni-Al-Bronze, Duplex Stainless Steel, Monel

Tubing & Fittings: Copper/brass, Stainless Steel, Optional: Monel

Flow Chart for full port valve

Cv (Kv)

Valve Size Inches (mm)	1.25 (32)	1.5 (40)	2 (50)	2.5 (65)	3 (75)	4 (100)	6 (150)	8 (200)	10 (250)	12 (300)	14 (350)	16 (400)	24 (600)
Globe Cv (Kv)	23 (19,8)	27 (23,2)	47 (40,4)	68 (53,5)	120 (103,2)	200 (172)	450 (387)	760 (653,6)	1,250 (1075)	1,940 (1668,4)	2,200 (1892)	2,850 (2451)	6,900 (5934)
Angle Cv (Kv)	30 (25,8)	35 (30,1)	65 (55,9)	87 (74,8)	160 (137,6)	270 (232,2)	550 (473)	1,000 (1376)	1,600 (1376)	2,400 (2064)	-	4,000 (3400)	-
Flow (GPM) @ 25 ft/sec	115	160	260	375	575	1,000	2,250	3,900	6,125	8,750	10,600	13,750	31,250
Flow (GPM) @ 45 ft/sec	210	280	460	650	1,000	1,800	4,000	7,000	11,000	16,000	19,000	25,000	56,000

MARK 5108 SERIES BACK PRESSURE REGULATING VALVES

DIMENSIONS

U.S. DIMENSIONS- INCHES

Dim.	End Conn.	1 1/4 - 1 1/2	2	2 1/2	3	4	6	8	10	12	14	16	24
A	Threaded	8 3/4	9 7/8	10 1/2	13	-	-	-	-	-	-	-	-
	Grooved	8 3/4	9 7/8	10 1/2	13	15 1/4	20	-	-	-	-	-	-
	150# Flg	8 1/2	9 3/8	10 1/2	12	15	17 3/4	25 3/8	29 3/4	34	39	40 3/8	62
	300# Flg	8 3/4	9 7/8	11 1/8	12 3/4	15 5/8	18 5/8	26 3/8	31 1/8	36 1/2	40 1/2	42	63 3/4
B	Threaded	1 7/16	1 11/16	1 7/8	2 1/4	-	-	-	-	-	-	-	-
	Grooved	1*	1 3/16	1 7/16	1 3/4	2 1/4	3 5/16	-	-	-	-	-	-
	150# Flg	2 5/16 - 2 1/2	3	3 1/2	3 3/4	4 1/2	5 1/2	6 3/4	8	9 1/2	10 5/8	11 3/4	16
	300# Flg	2 5/8 - 3 1/16	3 1/4	3 3/4	4 1/8	5	6 1/4	7 1/2	8 3/4	10 1/4	11 1/2	12 3/4	18
C Angle	Threaded	4 3/8	4 3/4	6	6 1/2	-	-	-	-	-	-	-	-
	Grooved	4 3/8*	4 3/4	6	6 1/2	7 5/8	-	-	-	-	-	-	-
	150# Flg	4 1/4	4 3/4	6	6	7 1/2	10	12 11/16	14 7/8	17	-	20 13/16	-
	300# Flg	4 3/8	5	6 3/8	6 3/8	7 13/16	10 1/2	13 3/16	15 9/16	17 3/4	-	21 5/8	-
D Angle	Threaded	3 1/8	3 7/8	4	4 1/2	-	-	-	-	-	-	-	-
	Grooved	3 1/8*	3 7/8	4	4 1/2	5 5/8	-	-	-	-	-	-	-
	150# Flg	3	3 7/8	4	4	5 1/2	6	8	11 3/8	11	-	15 11/16	-
	300# Flg	3 1/6	4 1/8	4 3/8	4 3/8	5 13/16	6 1/2	8 1/2	12 1/16	11 3/4	-	16 1/2	-
E	ALL	6	7	7	6 1/2	8	10	11 7/8	15 3/8	17	18	19	27
F	ALL	3 7/8	3 7/8	3 7/8	3 7/8	3 7/8	3 7/8	6 3/8	6 3/8	6 3/8	6 3/8	6 3/8	8
G	ALL	6	7 11/16	8 3/4	8 3/4	11 3/4	14	21	24 1/2	28	31 1/4	34 1/2	52
H	ALL	10	11	11	11	12	13	14	17	18	20	20	28 1/2

*Grooved end not available in 1 1/4"

METRIC DIMENSIONS- M.M

Dim.	End Conn.	DN32- DN40	DN50	DN65	DN80	DN100	DN150	DN200	DN250	DN300	DN350	DN400	DN600
A	Threaded	222	251	267	330	-	-	-	-	-	-	-	-
	Grooved	222	251	267	330	387	508	-	-	-	-	-	-
	150# Flg	216	238	267	305	381	451	645	756	864	991	1026	1575
	300# Flg	222	251	283	324	397	473	670	791	902	1029	1067	1619
B	Threaded	37	43	48	57	-	-	-	-	-	-	-	-
	Grooved	25*	30	37	44	57	84	-	-	-	-	-	-
	150# Flg	59 - 64	76	89	95	114	140	171	203	241	270	298	406
	300# Flg	67 - 78	83	95	105	127	159	191	222	260	292	324	457
C Angle	Threaded	111	121	152	165	-	-	-	-	-	-	-	-
	Grooved	111*	121	152	165	194	-	-	-	-	-	-	-
	150# Flg	108	121	152	152	191	254	322	378	432	-	529	-
	300# Flg	67 - 78	83	95	105	127	159	191	222	260	292	324	457
D Angle	Threaded	79	98	102	114	-	-	-	-	-	-	-	-
	Grooved	79*	98	102	114	143	-	-	-	-	-	-	-
	150# Flg	76	98	102	102	140	152	203	289	279	-	398	-
	300# Flg	79	105	111	111	148	165	216	306	298	-	419	-
E	ALL	152	152	178	165	203	254	302	391	432	457	483	686
F	ALL	98	98	98	98	98	98	162	162	162	162	162	203
G	ALL	152	171	195	222	298	356	533	622	711	794	876	1321
H	ALL	254	279	279	279	305	330	356	432	457	508	508	724

*Grooved end not available DN32

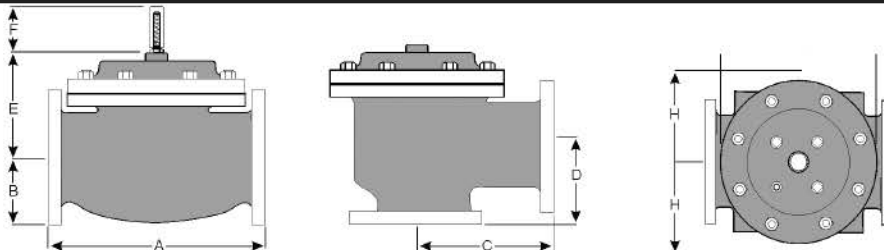

SCHEMATICS

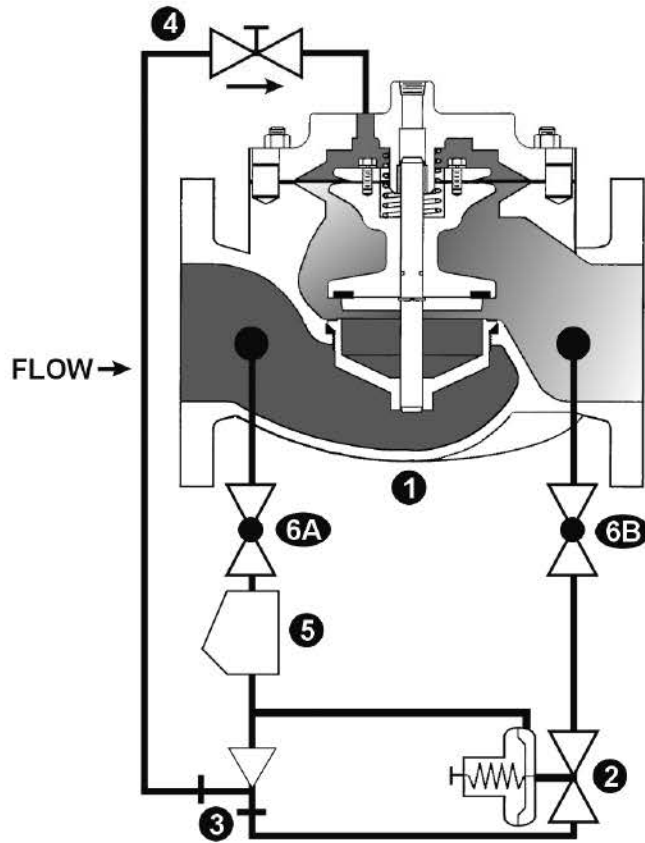

The Mark 5108 consists of the following components, arranged as shown on the schematic diagram:

1. **Main Valve:** A hydraulically-operated, diaphragm-actuated, globe or angle valve which closes with an elastomer-on-metal-seal.
2. **Pressure Relief Pilot:** A two-way, normally-closed pilot valve which senses upstream pressure under its diaphragm and balances it against an adjustable spring load. An increase in upstream pressure tends to make the pilot open.
3. **Ejector:** A simple “tee” fitting with a fixed orifice in its inlet port. It provides the proper pressure to the diaphragm chamber of the main valve depending on the position of the pressure reducing pilot.
4. **Flow Control Valve:** A needle-type valve which provides adjustable, restricted flow in one direction and free flow in the opposite direction. On the Mark 5108, the flow control valve is connected as a closing speed control.
5. **Y-Strainer** (standard on water service valves): The strainer protects the pilot system from solid contaminants in the line fluid.
- 6A/B. **Two Ball Valves** (standard on water service valves, optional on fuel service valves): Useful for isolating the pilot system for maintenance or trouble shooting.

PILOT

- Accurate sensing of outlet pressure
- Simple, single adjustment
- All parts replaceable while mounted on valve
- Rubber-to-metal seat for positive shut-off

- Large area diaphragm for quick, precise throttling
- Visual indication of diaphragm condition
- Bronze and stainless steel construction

1330

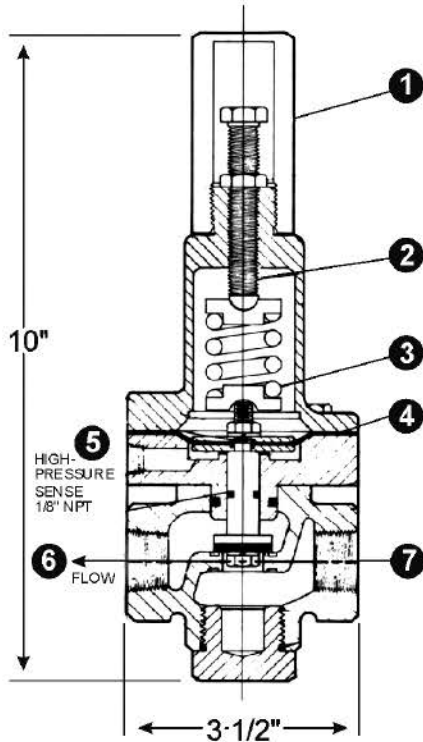

Pilot Materials

Bronze B-61
Stainless Steel ASTM A743/CF8M

Spring Ranges

5-30, 20-80, 65-180, 100-300 psi

**Model 1330/ 2400
Pressure Reducing Pilot**

1. Adjusting Screw Cover
2. Adjusting Screw
3. Spring
4. Diaphragm
5. Pressure Sense
6. Pilot Outlet
7. Pilot Inlet

2400

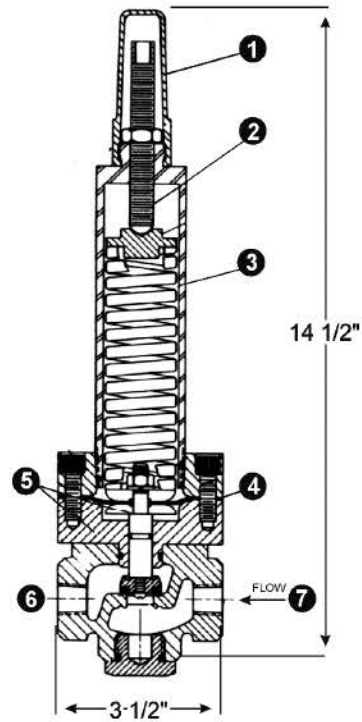

Pilot Materials

Stainless Steel ASTM A743/CF8M

Spring Ranges

200-750 psi

The Model 1330/2400 Pressure Sustaining Pilots control the amount of pressure in the upper chamber of the Main valve(s). (Hence, the degree of opening or closing of the Main valve). The upstream pressure increases, the pilot begins to open, decreasing the amount of pressure in the upper chamber of the main valve allowing it to open a proportionate amount, in order to maintain a constant inlet pressure. As the upstream pressure decreases, the pilot begins to close, allowing the pressure in the upper chamber of the main valve to increase causing it to close. This is a constant modulating action compensating for any change in upstream pressure.

SIZING CONSIDERATIONS

Surge Relief:

Size is determined by the amount of flow required to lower the inlet pressure. This relief flow can be difficult to determine, so a general guideline is to use 60% of the rated pump flow. The 108 Series valve is capable of intermittent flows up to 45 ft. per second. Relief valve sizes are typically 50-60% of the mainline size.

Pressure Sustaining:

Sustaining valves are typically main line size. However, maximum velocity through the valve should not exceed 25 ft/sec.

Bypass Pressure Control:

Bypass pressure control valves are sized based on maximum flow and pressure drop across the valve. The maximum flow through the valve is the pump flow at the desired set point (from the pump curve) minus the minimum system flow. The pressure drop across the valve is the set point minus the pressure at the valve discharge (typically pump suction or storage tank head). Determine the valve's operating Cv using the maximum flow and pressure drop from the formula:

Where:

- Qmax = maximum flow rate, gallons per minute
- DP = pressure drop, psi
- sg = liquid specific gravity (water = 1.00)

$$C_v = \frac{Q_{\max}}{\sqrt{\frac{DP}{sg}}}$$

From the Cv chart on Page 2, pick the smallest valve that has at least the Cv determined above, and where the velocity does not exceed 25 ft/sec.

How to Order Your Valve

When ordering, please provide:

- Series Number
- Valve Size
- Globe/Angle
- Pressure Class
- Threaded/ Flanged/ Grooved
- Trim Material
- Adjustment Range
- Pilot Options
- Special Needs/ Installation Requirements

