

JRHF Series

Pressure Regulating Valves

PRESSURE REGULATING VALVE

The JRHF Series is a diaphragm operated, balanced trim pressure regulator. The choice between 1.5 and 1.9 Cv offers increased flows across the JRHF's 230 psi inlet range, while the PTFE soft seat provides ANSI Class VI shutoff. Four set spring ranges and three soft seal options offer the customer flexibility in a number of applications and environments. These valves are designed to regulate a variety of gases and liquids in applications where high flows and low control pressures are required.

Features:

- Top entry design facilitates in-line cleaning and maintenance
- Barstock construction guarantees material integrity and surface finish
- Balanced trim offers high flows with minimal lockup
- Optimized internal volume
- Proprietary Jorlon diaphragm provides exceptionally long life
- PTFE or PEEK soft seat for ANSI Class VI shutoff



JRHF SERIES FLOW CONFIGURATIONS

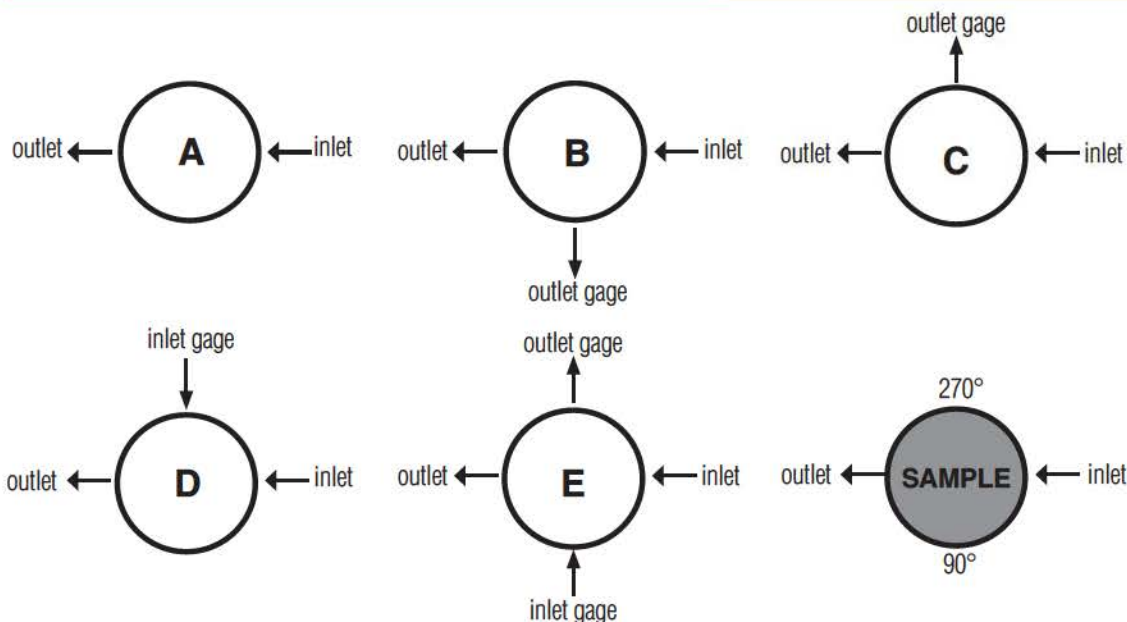

Top View

Gage ports are 1/4" FNPT; Consult factory for other porting options

JRHF SERIES SPECIFICATIONS

Line Size: 1/2", 3/4", 1" (DN15, DN20, DN25)

End Connections

- Threaded
- Socket Weld
- Flanged

Materials

- PTFE soft seat to +150°F (+66°C)
- PEEK soft seat to +250°F (+177°C)
- 316L SST- Standard
- Contact factory for other body/trim/seat materials

Diaphragm Material: Jorlon

Maximum Inlet Pressure: 230 psig (16 bar)

Pressure at Maximum Temperature: 150 psi @ 275°F

Spring Ranges

- 0-20 psi (0 - 1,4 bar)
- 0-50 psi (0 - 3,4 bar)
- 0-100 psi (0 - 6,9 bar)
- 0-150 psi (0 - 10,3 bar)

Flow Characteristics

- Cv 1.5 for 1/2", Cv 1.9 for 3/4" and 1"

Options

- Panel Mounting
- Captured Vent
- Locking Wire
- Tamper Proof
- Lockout Device

OPTIONS & DEFINITIONS

Panel Mount The panel mount feature utilizes a threaded spring housing and a panel mount ring to secure the regulator to an instrument panel. This option requires a 1-1/2" panel cut out.

Captured Vent The captured vent design provides maximum safety for the user when handling toxic or hazardous media. It features a 1/8" FNPT port located on the spring housing. The user can easily tube this vent to a safe location. This option can be incorporated into a self-relieving regulator that provides an additional port to permit the safe expulsion of hazardous media.

Locking Wire The locking wire option utilizes a lead sealed metal wire to physically hold the adjusting screw in place to prevent any unwanted set point changes.

Tamper Proof The tamper proof option replaces the standard adjusting knob with a stainless steel acorn nut.

Lockout Device The lockout device is a 2 piece polypropylene enclosure which encapsulates the adjustment knob and prevents unwanted set point changes. The part number required for this valve is 26971. (Lock not included)

JRHF SIZING

1. Use the "LVCV Sizing Software" link found on the www.lowflowvalve.com home page and navigate to LowFlow valve sizing.
2. Use the software to size for flow using the listed CV of the valve and the customer's application conditions.
3. The JRHF is rated to 60% of the flow value found using LVCV. There is no low-end cutoff limit.

Example:

Air, ambient temperature, P1 = 200 psi, P2 = 80 psi, 1" schedule 40 pipe, flow rate 7,800 SCFH

Using LVCV to size for flow we find that these conditions and a 1.9 CV will result in a maximum flow of 13,212 scfh. Multiply this value by 0.60 to find the maximum rated flow for the JRHF-100-6L. Your result will be 7,927 scfh (13,212 x 0.6 = 7,927). Any flow below this result is acceptable for the valve.

JRHF SERIES FEATURES AND BENEFITS

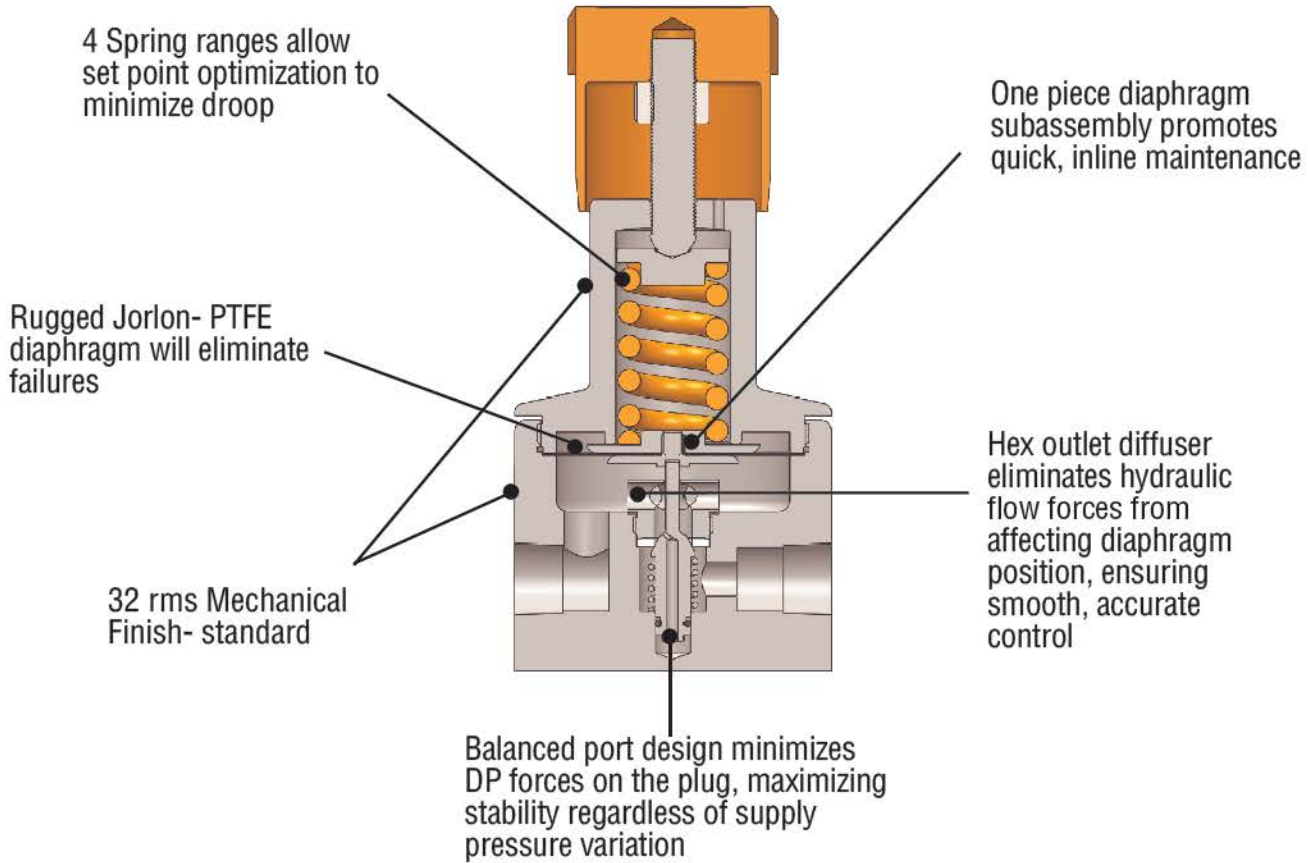

JRHF DIMENSIONS

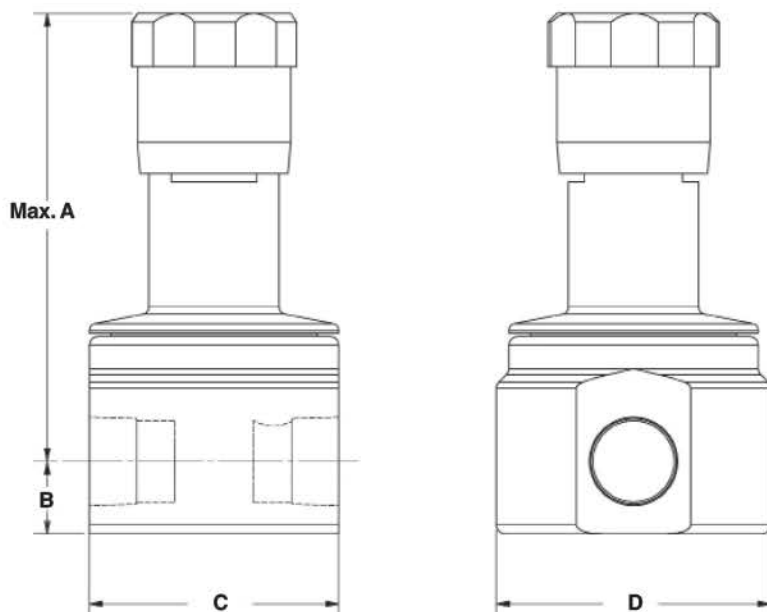

| VALVE SIZE | DIMENSIONS, INCHES | | | | WEIGHT, LBS |
|----------------|--------------------|------|------|------|-------------|
| | A | B | C | D | |
| 1/2", 3/4", 1" | 6.29 | 1.02 | 3.50 | 3.85 | 9 |

| VALVE SIZE | DIMENSIONS, MM | | | | WEIGHT, KGS |
|------------------|----------------|----|----|----|-------------|
| | A | B | C | D | |
| DN15, DN20, DN25 | 160 | 26 | 89 | 98 | 4,1 |

JRHF SERIES ORDERING SCHEMATIC

| Model | Size | Material | 1 & 2 | 3 & 4 | 5 & 6 | 7 & 8 | 9 & 10 | 11 & 12 | 13 & 14 | 15 | 16 | 17 |
|-------|------|----------|-------|-------|-------|-------|--------|---------|---------|----|----|----|
| — | — | — | — | — | — | — | — | — | — | — | — | — |

| Model | |
|-------|-------------------------|
| JRHF | Pressure Reducing Valve |

| Size | |
|------|------|
| 050 | 1/2" |
| 075 | 3/4" |
| 100 | 1 |

| Material | |
|----------|----------------------|
| 6L | Stainless Steel 316L |

| 1 & 2 | Body Feature | |
|----------------|--------------------|------------|
| End Connection | Port Configuration | |
| C | FNPT | A Port "A" |
| | | B Port "B" |
| | | C Port "C" |
| | | D Port "D" |
| | | E Port "E" |
| ZZ | Non-Standard | |

| 3 & 4 | Trim |
|-------|--------------|
| 1E | EPDM & 6L |
| 1V | VIT & 6L |
| 1K | Buna-N & 6L |
| ZZ | Non-Standard |

| 5 & 6 | Seat Material |
|-------|---------------------------|
| TF | PTFE (1/2" 1.5 Cv) 1.9 Cv |
| PK | PEEK (1/2" 1.5 Cv) 1.9 Cv |
| ZZ | Non-Standard |

| 7 & 8 | Range Spring/Outlet Pressure |
|-------|------------------------------|
| 02 | 0-20 PSI |
| 05 | 0-50 PSI |
| 10 | 0-100 PSI |
| 15 | 0-150 PSI |
| ZZ | Non-Standard |

| 9 & 10 | Diaphragm Material |
|--------|--------------------|
| JL | Jorlon |
| ZZ | Non-Standard |

| 11 & 12 | Actuator |
|---------|--------------|
| SK | Standard |
| PM | Panel Mount |
| ZZ | Non-Standard |

| 13 & 14 | Inlet Gauge |
|---------|-----------------------|
| AA | 0-30 PSIG/BAR (Dual) |
| BB | 0-60 PSIG/BAR (Dual) |
| CC | 0-100 PSIG/BAR (Dual) |
| DD | 0-160 PSIG/BAR (Dual) |
| EE | 0-200 PSIG/BAR (Dual) |
| FF | 0-300 PSIG/BAR (Dual) |
| ON | None |
| ZZ | Non-Standard |

| 15 | Outlet Gauge |
|----|-----------------------|
| 0A | 0-30 PSIG/BAR (Dual) |
| 0B | 0-60 PSIG/BAR (Dual) |
| 0C | 0-100 PSIG/BAR (Dual) |
| 0D | 0-160 PSIG/BAR (Dual) |
| 0E | 0-200 PSIG/BAR (Dual) |
| ON | None |
| Z | Non-Standard |

| 16 | SEP Compliance |
|----|----------------|
| G | SEP Compliant |
| Z | Non-Standard |

| 17 | Accessories |
|----|---------------------|
| S | Clean for Oil Free* |
| X | Clean for Oxygen* |
| Z | Non-Standard |

*Consult factory for compatible gauge options