

Mark ED & ET Series

8" Globe Style Control Valves

The Mark E Series is a single port, globe-style body with composition or metal seats and a balanced push-down-to-close valve action plug.

There are two styles of valve available, providing excellent pressure and flow control on steam gasses and various liquid applications:

The **Mark ED Series** is intended for general control applications over a wide variety of temperatures and pressure drops. This design has an upper piston ring seal and metal-to-metal seating.

The **Mark ET Series** is intended for applications requiring low leakage rates with composition seating (TFE) for tight shutoff requirements or metal-to-metal seating for higher temperature capabilities. The valve plug has a two-piece upper seal.

FEATURES

- Top entry cage design allows easy, in-line maintenance
- Balanced Plug allows the use of smaller actuators
- Characterized flow options including equal percentage, linear, and quick opening
- Available in a variety of body and trim materials make the Mark E Series suitable for a variety of applications including liquids, gasses or steam
- Cage guiding allows the Mark E to handle high pressure drops while providing greater plug stability
- Sour Service Capability: Optional NACE MRO175/ISO15156-2009
- Tight shutoff



Mark ED/ET Series 8" Control Valve

MARK ED AND ET SERIES 8" GLOBE STYLE CONTROL VALVE

SPECIFICATIONS

Sizes: 8"

End Connections:

- ANSI Flanges- Class 150, 300 and 600
- Raised Face, or Ring Type Joint flanges as per ASME B16.34-latest edition.

Body Materials:

- LCC
- WCB
- WCC
- WC9
- C5
- Monel
- CF8M SST
- Additional materials may be available upon request

Trim Materials:

- 316SST
- 416SST
- 17-4PH
- Alloy6-Co.Cr-A
- Cobalt
- 316SST/Tungsten Carbide

Seats:

- Metal
- PTFE

Shutoff:

- Mark ET: ANSI Class IV & V
- Mark ED: ANSI Class II & III

Maximum Inlet Pressures and Temperatures: The Maximum Inlet Pressure and Temperature is consistent with ASME Class per ASME 16.34

Maximum Pressure Drops: All Valves are capable of Full Rated Pressure Drops

Flow Characteristics:

- Quick opening
- Linear
- Equal percent

Trim Options:

- Noise abatement
- Anti-cavitation

Flow Direction:

- **Normally Down**, Linear, Quick Opening, Equal Percent
- **Always Up**, Noise Abatement
- **Always Down**, Anti-Cav

Valve Travel Indication: Valves are supplied with Visual Travel Indicator

DIMENSIONAL DATA

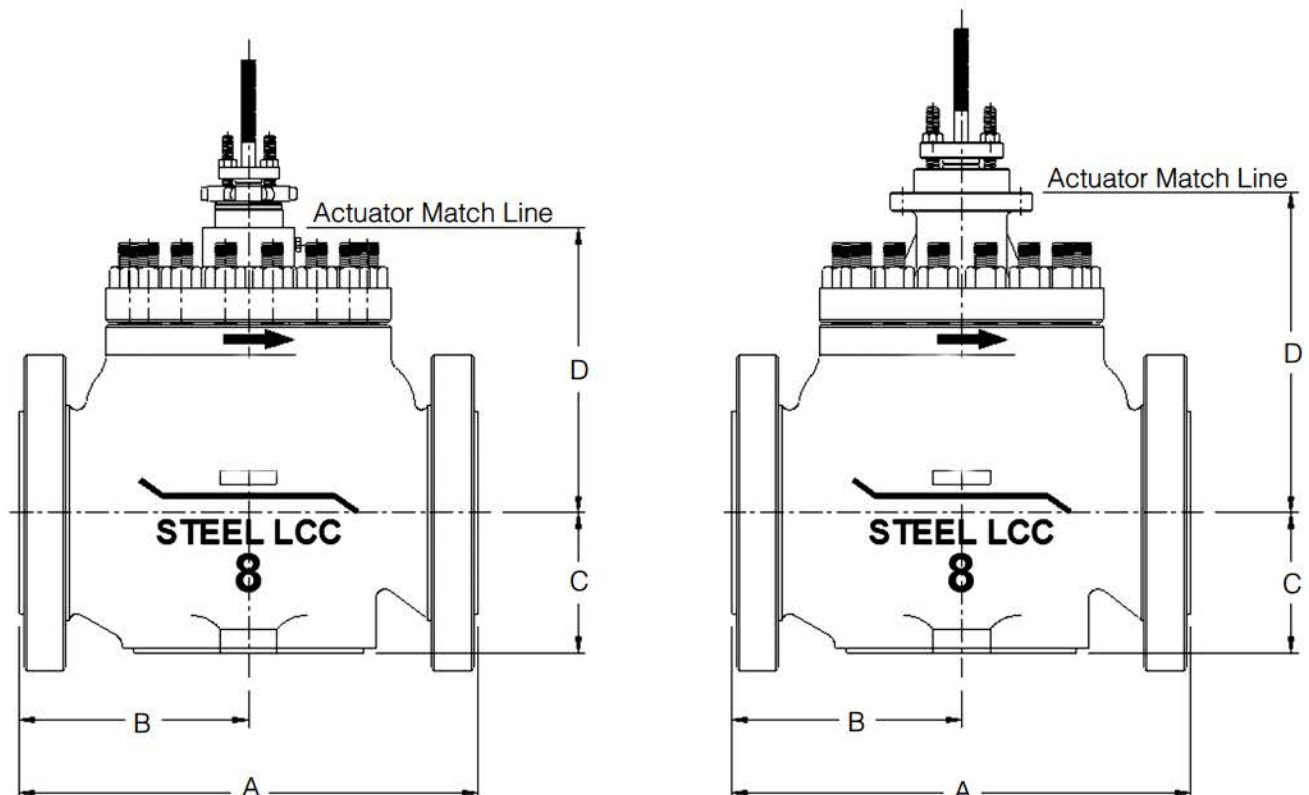

MARK ED AND ET SERIES 8" GLOBE STYLE CONTROL VALVE

End Connection Style

Valve Size		Dimension "A**"											
		150 RF		150 RTJ		300 RF		300 RTJ		600 RF		600 RTJ	
in	mm	in	mm	in	mm	in	mm	in	mm	in	mm	in	mm
8	203	21.38	543	21.88	556	22.38	568	23.00	584	24.00	610	24.12	613

* – Dimension B=DimA/2

Valve Size		Dimension "D" Standard Bonnet		Dimension "D" Extension Bonnet		Dimension "C" Max	
		Stem Diameter		Stem Diameter			
in	mm	3/4	19.1	3/4	19.1	in	mm
		in	mm	in	mm		
8	203	14.75	375	16.56	421	7.50	191

Approximate shipping weight: 408kg (900lbs)

Flow Coefficients

Quick Opening- Mark ED																	
Valve Size, NPS	Port Diameter		Maximum Travel		Flow Coefficient	Cv for 0.25" (6mm) Travel	Valve Opening- Percent of Total Travel										FL ⁽¹⁾
	in.	mm	in.	mm			10	20	30	40	50	60	70	80	90	100	
8	8	203,2	2	51	Cv	108	80.3	188	290	389	480	554	615	658	705	744	0.87
					Kv	93.4	69.5	163	251	336	415	479	532	569	610	644	---
					Xt	0.653	0.670	0.628	0.679	0.731	0.766	0.806	0.829	0.859	0.863	0.866	---
8	8	203,2	3	76	Cv	108	135	291	434	551	639	706	759	807	841	863	0.85
					Kv	93.4	117	252	375	477	533	611	657	698	727	746	---
					Xt	0.653	0.643	0.699	0.757	0.807	0.838	0.861	0.857	0.841	0.838	0.827	---
					Fd	---	0.19	0.24	0.26	0.27	0.28	0.28	0.28	0.28	0.28	0.27	---

1. At 100% Travel

Linear- Mark ED																
Valve Size, NPS	Port Diameter		Maximum Travel		Flow Coefficient	Valve Opening- Percent of Total Travel										FL ⁽¹⁾
	in.	mm	in.	mm		10	20	30	40	50	60	70	80	90	100	
8	8	203,2	2	51	Cv	60.2	129	206	285	363	444	526	581	640	688	0.87
					Kv	52.1	112	178	247	314	384	455	503	554	595	---
					Xt	0.740	0.721	0.657	0.651	0.683	0.713	0.740	0.801	0.821	0.839	---
8	8	203,2	3	76	Cv	91.4	207	325	440	550	639	711	760	795	846	0.87
					Kv	79.1	179	281	381	476	533	615	657	688	732	---
					Xt	0.651	0.624	0.677	0.746	0.786	0.803	0.823	0.836	0.843	0.807	---
					Fd	0.23	0.28	0.30	0.31	0.31	0.31	0.31	0.31	0.31	0.31	0.31

1. At 100% Travel

MARK ED AND ET SERIES 8" GLOBE STYLE CONTROL VALVE

Flow Coefficients

Equal Percent – Mark ED, Flow Down																
Valve Size, NPS	Port Diameter		Maximum Travel		Flow Coefficient	Valve Opening- Percent of Total Travel										FL ⁽¹⁾
	in.	mm	in.	mm		10	20	30	40	50	60	70	80	90	100	
8	8	203,2	2	51	Cv	18.5	38.0	58.4	86.7	130	189	268	371	476	567	0.85
					Kv	16.0	32.9	50.5	75.0	112	163	232	321	412	490	---
					Xt	0.727	0.623	0.600	0.588	0.580	0.587	0.599	0.611	0.67	0.725	---
8	8	203,2	3	76	Cv	27.0	58.1	105	188	307	478	605	695	761	818	0.86
					Kv	23.4	50.3	90.8	163	266	413	523	601	658	708	---
					Xt	0.644	0.654	0.636	0.611	0.643	0.15	0.725	0.809	0.80	0.807	---
					Fd	0.28	0.26	0.23	0.20	0.17	0.22	0.24	0.25	0.25	0.26	---

1. At 100% Travel

Noise Abatement 1- Flow Up, Mark ED															
Valve Size, NPS	Port Diameter		Maximum Travel		Flow Coefficient	Valve Opening- Percent of Total Travel									
	in.	mm	in.	mm		10	20	30	40	50	60	70	80	90	100
8	8	203,2	3 ⁽¹⁾	76 ⁽¹⁾	Cv	100	226	337	436	502	581	641	655	659	681
					Kv	86.5	195	292	377	434	503	554	567	570	589
					Xt	0.456	0.490	0.470	0.427	0.452	0.468	0.521	0.624	0.703	0.701
8	8	203,2	4	102	Cv	142	303	428	542	611	652	669	689	700	726
					Kv	123	262	370	469	529	564	579	596	606	628
					Xt	123	262	370	469	529	564	579	596	606	628
					Fd	0.549	0.450	0.436	0.441	0.513	0.624	0.707	0.709	0.729	0.718

1. Travel is limited to 2.75" with a Class IV ED valve plug

MARK ED AND ET SERIES 8" GLOBE STYLE CONTROL VALVE

Flow Coefficients

Quick Opening - Mark ET																	
Valve Size, NPS	Port Diameter		Maximum Travel		Flow Coefficient	Cv for 0.25" (6mm) Travel	Valve Opening- Percent of Total Travel										FL ⁽¹⁾
	in.	mm	in.	mm			10	20	30	40	50	60	70	80	90	100	
8	8	203,2	2	51	Cv	108	80.3	188	290	389	480	554	615	658	705	744	0.87
					Kv	93.4	69.5	163	251	336	415	479	532	469	610	644	---
					Xt	0.653	0.67	0.628	0.679	0.731	0.766	0.806	0.829	0.86	0.863	0.866	---
8	8	203,2	3	76	Cv	108	135	291	434	551	639	706	759	807	841	863	0.85
					Kv	93.4	117	252	375	477	553	611	657	698	727	746	---
					Xt	0.653	0.64	0.699	0.757	0.807	0.838	0.861	0.857	0.84	0.838	0.827	---
					Fd	---	0.19	0.24	0.26	0.27	0.28	0.28	0.28	0.28	0.28	0.28	0.27

1. At 100% Travel

Linear- Design ET																
Valve Size, NPS	Port Diameter		Maximum Travel		Flow Coefficient	Valve Opening- Percent of Total Travel										FL ⁽¹⁾
	in.	mm	in.	mm		10	20	30	40	50	60	70	80	90	100	
8	8	203,2	2	51	Cv	60.2	129	206	285	363	444	526	581	640	688	0.87
					Kv	52.1	112	178	247	314	384	455	503	554	595	---
					Xt	0.704	0.721	0.657	0.651	0.683	0.713	0.740	0.801	0.821	0.839	---
8	8	203,2	3	76	Cv	91.4	207	325	440	550	639	711	760	795	846	0.87
					Kv	79.1	179	281	381	476	553	615	657	688	732	---
					Xt	0.651	0.624	0.677	0.746	0.786	0.803	0.823	0.836	0.843	0.807	---
					Fd	0.23	0.28	0.30	0.31	0.31	0.31	0.31	0.31	0.31	0.31	0.31

1. At 100% Travel

MARK ED AND ET SERIES 8" GLOBE STYLE CONTROL VALVE

Flow Coefficients

Equal Percent – Mark ET																
Valve Size, NPS	Port Diameter		Maximum Travel		Flow Coefficient	Valve Opening- Percent of Total Travel										FL ⁽¹⁾
	in.	mm	in.	mm		10	20	30	40	50	60	70	80	90	100	
8	8	203,2	2	51	Cv	18.5	38.0	58.4	86.7	130	189	268	371	476	567	0.85
					Kv	16.0	32.9	50.5	75.0	112	163	232	321	412	490	---
					Xt	0.727	0.623	0.600	0.588	0.580	0.587	0.599	0.611	0.671	0.724	---
8	8	203,2	3	76	Cv	27.0	58.1	105	188	307	478	605	695	761	818	0.86
					Kv	23.4	50.3	90.8	163	266	413	523	601	658	708	---
					Xt	0.644	0.654	0.636	0.611	0.643	0.15	0.725	0.809	0.804	0.807	---
					Fd	0.28	0.26	0.23	0.20	0.17	0.22	0.24	0.25	0.25	0.26	---

1. At 100% Travel

Shutoff Classifications

Valve Design	Mark ET Series		Mark ED Series	
	Seating	Shutoff Class	Standard	Optional
All valve designs with the exception of Anti-Cav III cages	PTFE (standard)	IV Standard	Class II	Class III, Valves with Graphite
		V (optional)		
	Metal	IV		
V (optional)				
ET with Anti-Cav III Single Stage cage	Metal	IV Standard		
		V (optional)		
ET with Anti-Cav III two stage cage	Metal	V		

