

FIRE PROTECTION PRODUCTS

Mueller® Indicator Post are used in fire protection systems and perform several functions. The Indicator Post provides a means to operate a buried or otherwise inaccessible valve. Also, the Indicator Post readily and clearly indicates whether the valve is open or shut. All Mueller Indicator Posts are **UL** listed and 4-14" Indicator Posts are FM Approved. Mueller Indicator Posts are designed to withstand up to 900 ft. - lbs. of operating torque.

Mueller Indicator Posts are designed to operate 4" through 24" post indicator valves requiring 14 to 75 turns to open, and can be ordered to open left or open right. They are available in adjustable, non-adjustable or wall mount styles. All have a cast boss on the upper barrel that is tapped with 1/2" NPT to allow a supervisory switch to be installed.

The Mueller Adjustable Indicator Post has a 24.25" adjustment range* and can be easily adjusted in the field without disassembly. The unique telescoping stem shaft design speeds field adjustment and eliminates the need to disassemble and saw off sections of stem. The base bell is attached to the lower barrel with large diameter set screws to speed installation. The upper barrel is made of tough carbon steel, and the telescoping lower barrel is made of schedule 40 PVC material (ductile iron is optional). The Mueller design uses the operating wrench to make the post tamper proof. The operating wrench can be stored on the Indicator Post (as shown in the illustration to the right) so that one end of wrench fits over the post operating nut to secure it in position. A slot in the wrench handle fits over a post on the barrel. A customer supplied padlock can be used to lock the operating wrench to the barrel to resist unauthorized operation.

The Mueller Wall Mount Indicator Post is used to operate a valve installed behind a wall and indicates if that valve is open or shut. The Post has a 12" diameter base with 3/4" bolt holes which can be mounted to a wall.

**Applies to "ORDER LENGTH" codes B through F; code A has 22" adjustment.
All 4"-14" Posts are preset for a Mueller 6" PIV Open Left
All 16"-24" Posts are preset for a Mueller 24" PIV Open Left*

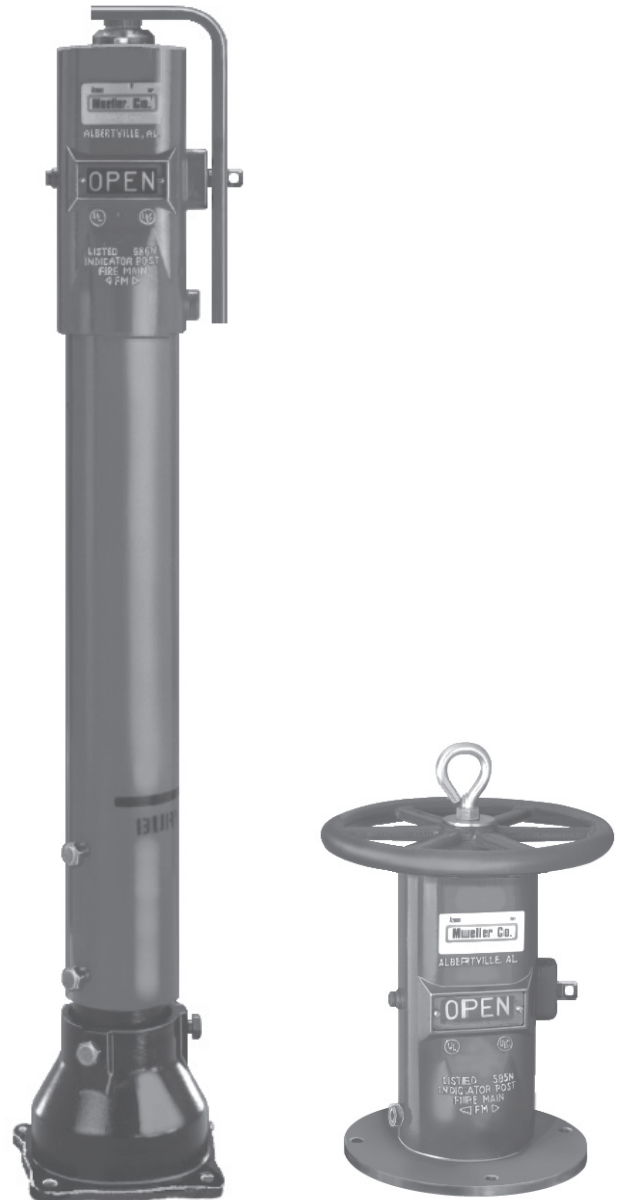

SECTION
E-1

Rev. 03-18

Shaded area indicates change

**ADJUSTABLE
INDICATOR POST
FOR 4"-14" VALVES**



UL / FM

FIRE PROTECTION PRODUCTS



A-20806

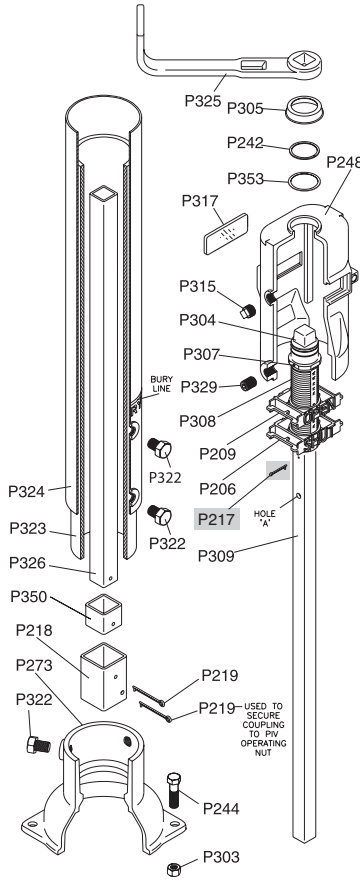

A-20806: Adjustable Type Indicator Post

□ UL Listed □ FM Approved

PARTS LIST

Catalog Part No.	Description	Material	Material Standard
P206	SHUT Target	Plastic	Nylon
P209	OPEN Target	Plastic	Nylon
P217	Cotter Pin (short)	Brass	ASTM B21
P218	Coupling	Steel	ASTM A500 GR.B
P219	Cotter Pin (long)	Brass	ASTM B21
P242	Retaining ring	Stainless Steel	AISI 302
P244	Hex Bolt	Steel/zinc plated	ASTM A307 GR.A
P248	Post Head	Cast Iron**	ASTM A126 CL.B
P273	Bell	Cast Iron	ASTM A126 CL.B
P303	Hex Nut	Steel/zinc plated	ASTM A563 GR.B
P304	Operating Nut	Ductile Iron	ASTM A536
P305	Cap	Plastic	Polypropylene
P307	Spring pin	Stainless Steel	AISI 420
P308	Threaded sleeve	Plastic	Nylon
P309	Upper stem	Steel	ASTM A513
P315	Pipe plug - hex socket	Steel	-
P317	Window	Polycarbonate	-
P322	Hex head screw	Steel/zinc plated	SAE J429
P323	Lower Barrel	PVC***	DR14 UL Listed
P324	Upper Barrel	Steel	ASTM A53 GR.B
P325	Wrench	Ductile Iron	ASTM A536
P326	Lower Stem	Steel	ASTM A500 GR.B
P329	Socket head set screw	Steel	ANSI B18.3
P350	Coupling Insert	Steel	ASTM A500 GR.B
P353	Washer*	Stainless Steel	AISI 304

* Washer use discontinued in 2011. Not required when P305 cap is used.

** Manufacturers option to change material to Ductile iron ASTM A536

*** Optional ductile iron lower barrel available.

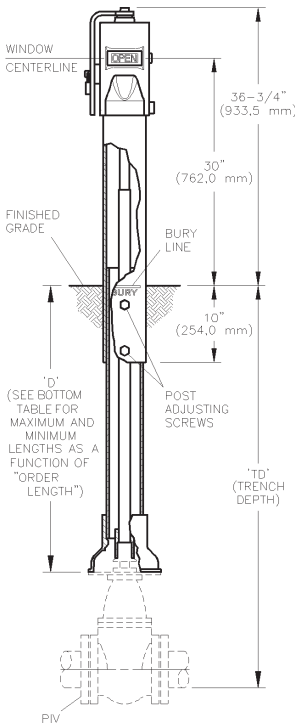

**NOMINAL TRENCH DEPTHS
FOR MUELLER RESILIENT WEDGE POST INDICATOR VALVES**

Valve Size	"ORDER LENGTH" A		"ORDER LENGTH" B		"ORDER LENGTH" C		"ORDER LENGTH" D		"ORDER LENGTH" E		"ORDER LENGTH" F	
	Min.	Max.	Min.	Max.	Min.	Max.	Min.	Max.	Min.	Max.	Min.	Max.
4"	2' - 7"	4' - 5"	4' - 1"	6' - 2"	5' - 10"	7' - 11"	7' - 6"	9' - 8"	9' - 4"	11' - 5"	11' - 1"	13' - 2"
6"	3' - 0"	4' - 10"	4' - 6"	6' - 7"	6' - 3"	8' - 4"	8' - 0"	10' - 1"	9' - 9"	11' - 10"	11' - 6"	13' - 7"
8"	3' - 4"	5' - 2"	4' - 11"	6' - 11"	6' - 8"	8' - 8"	8' - 5"	10' - 5"	10' - 2"	12' - 2"	11' - 11"	13' - 11"
10"	3' - 8"	5' - 6"	5' - 3"	7' - 3"	6' - 10"	9' - 0"	8' - 9"	10' - 9"	10' - 6"	12' - 6"	12' - 3"	14' - 3"
12"	4' - 0"	5' - 10"	5' - 7"	7' - 7"	7' - 4"	9' - 4"	9' - 1"	11' - 1"	10' - 10"	12' - 10"	12' - 7"	14' - 7"
14"	4' - 6"	6' - 4"	6' - 1"	8' - 1"	7' - 10"	9' - 10"	9' - 7"	11' - 7"	11' - 4"	13' - 4"	13' - 1"	15' - 1"

D DIMENSION ADJUSTMENT RANGE

	"ORDER LENGTH" A	"ORDER LENGTH" B	"ORDER LENGTH" C	"ORDER LENGTH" D	"ORDER LENGTH" E	"ORDER LENGTH" F
Min.	17.25"	36.00"	57.00"	78.00"	99.00"	120.00"
Max.	39.25"	60.25"	81.25"	102.25"	123.25"	144.25"

FIRE PROTECTION PRODUCTS

ADJUSTABLE INDICATOR POST FOR 16"-24" VALVES

A-20807: Adjustable Type Indicator Post

□ UL Listed



A-20807

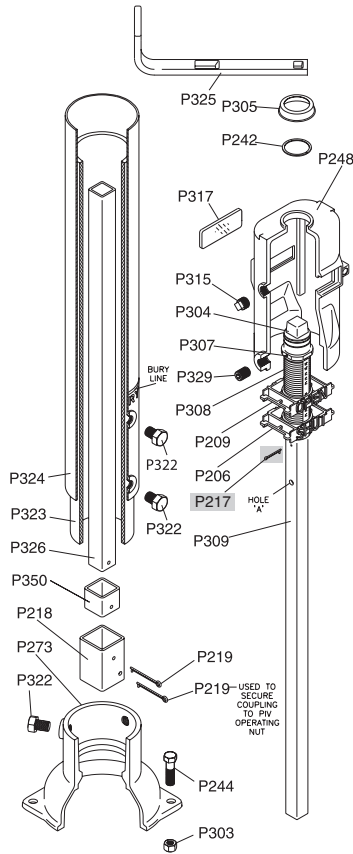

PARTS LIST

Catalog Part No.	Description	Material	Material Standard
P206	SHUT Target	Plastic	Nylon
P209	OPEN Target	Plastic	Nylon
P217	Cotter Pin (short)	Brass	ASTM B21
P218	Coupling	Steel	ASTM A500 GR.B
P219	Cotter Pin (long)	Brass	ASTM B21
P242	Retaining ring	Stainless Steel	AISI 302
P244	Hex Bolt	Steel/zinc plated	ASTM A307 GR.A
P248	Post Head	Cast Iron*	ASTM A126 CL.B
P273	Bell	Cast Iron	ASTM A126 CL.B
P303	Hex Nut	Steel/zinc plated	ASTM A563 GR. B
P304	Operating Nut	Ductile Iron	ASTM A536
P305	Cap	Plastic	Polypropylene
P307	Spring pin	Stainless Steel	AISI 420
P308	Threaded sleeve	Plastic	Nylon
P309	Upper stem	Steel	ASTM A513
P315	Pipe plug - hex socket	Steel	-
P317	Window	Polycarbonate	-
P322	Hex head screw	Steel/zinc plated	SAE J429
P323	Lower Barrel	PVC**	DR14 UL Listed
P324	Upper Barrel	Steel	ASTM A53 GR.B
P325	Wrench	Steel	ASTM A35 HRS
P326	Lower Stem	Steel	ASTM A500 GR.B
P329	Socket head set screw	Steel	ANSI B18.3
P350	Coupling Insert	Steel	ASTM A500 GR.B

* Manufacturers option to change material to Ductile iron ASTM A536

** Optional ductile iron lower barrel available.

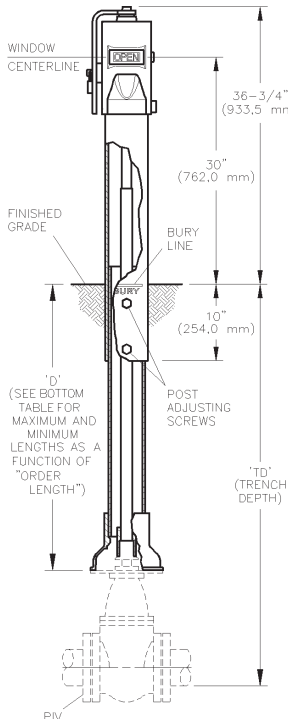

NOMINAL TRENCH DEPTHS FOR MUELLER RESILIENT WEDGE POST INDICATOR VALVES

Valve Size	"ORDER LENGTH" A		"ORDER LENGTH" B		"ORDER LENGTH" C		"ORDER LENGTH" D		"ORDER LENGTH" E		"ORDER LENGTH" F	
	Min.	Max.	Min.	Max.	Min.	Max.	Min.	Max.	Min.	Max.	Min.	Max.
16"	4' - 10"	6' - 8"	6' - 5"	8' - 5"	8' - 2"	10' - 2"	9' - 11"	11' - 11"	11' - 8"	13' - 8"	13' - 5"	15' - 5"
18"	5' - 5"	7' - 3"	7' - 0"	9' - 0"	8' - 9"	10' - 9"	10' - 6"	12' - 6"	12' - 3"	14' - 3"	14' - 0"	16' - 0"
20"	5' - 10"	7' - 8"	7' - 4"	9' - 5"	9' - 1"	11' - 2"	10' - 10"	12' - 11"	12' - 7"	14' - 8"	14' - 4"	16' - 5"
24"	6' - 6"	8' - 4"	8' - 1"	10' - 1"	9' - 10"	11' - 10"	11' - 7"	13' - 7"	13' - 4"	15' - 4"	15' - 1"	17' - 1"

D DIMENSION ADJUSTMENT RANGE

	"ORDER LENGTH" A	"ORDER LENGTH" B	"ORDER LENGTH" C	"ORDER LENGTH" D	"ORDER LENGTH" E	"ORDER LENGTH" F
Min.	17.25"	36.00"	57.00"	78.00"	99.00"	120.00"
Max.	39.25"	60.25"	81.25"	102.25"	123.25"	144.25"

**NON-ADJUSTABLE TYPE
INDICATOR POST
FOR 4"-14" VALVES**



A-20808: Non-Adjustable Indicator Post

UL Listed FM Approved

PARTS LIST

Catalog Part No.	Description	Material	Material Standard
P206	SHUT Target	Plastic	Nylon
P209	OPEN Target	Plastic	Nylon
P217	Cotter Pin (short)	Brass	ASTM B21
P218	Coupling	Steel	ASTM A500 GR.B
P219	Cotter Pin (long)	Brass	ASTM B21
P238	Barrel	Steel	ASTM A500 GR.B
P242	Retaining Ring	Stainless Steel	AISI 302
P244	Hex Bolt	Steel/zinc plated	ASTM A307 GR.A
P248	Post Head	Cast Iron**	ASTM A126 CL.B
P273	Bell	Ductile Iron	ASTM A536
P303	Hex Nut	Steel/zinc plated	ASTM A563 GR.B
P304	Operating Nut	Ductile Iron	ASTM A536
P305	Cap	Polypropylene	-
P307	Spring pin	Stainless Steel	AISI 420
P308	Threaded sleeve	Plastic	Nylon
P309	Upper stem	Steel	ASTM A513
P315	Pipe plug - hex socket	Steel	-
P317	Window	Polycarbonate	-
P322	Hex HD Screw	Steel/Zinc Plated	SAE J429
P325	Wrench	Ductile Iron	ASTM A536
P326	Lower Stem	Steel	ASTM A500 GR.B
P329	Socket head set screw	Steel	ANSI B18.3
P350	Coupling insert	Steel	ASTM A500 GR.B
P353	Washer*	Stainless Steel	AISI 304

* Washer use discontinued in 2011. Not required when P305 cap is used.

** Manufacturers option to change material to Ductile iron ASTM A536

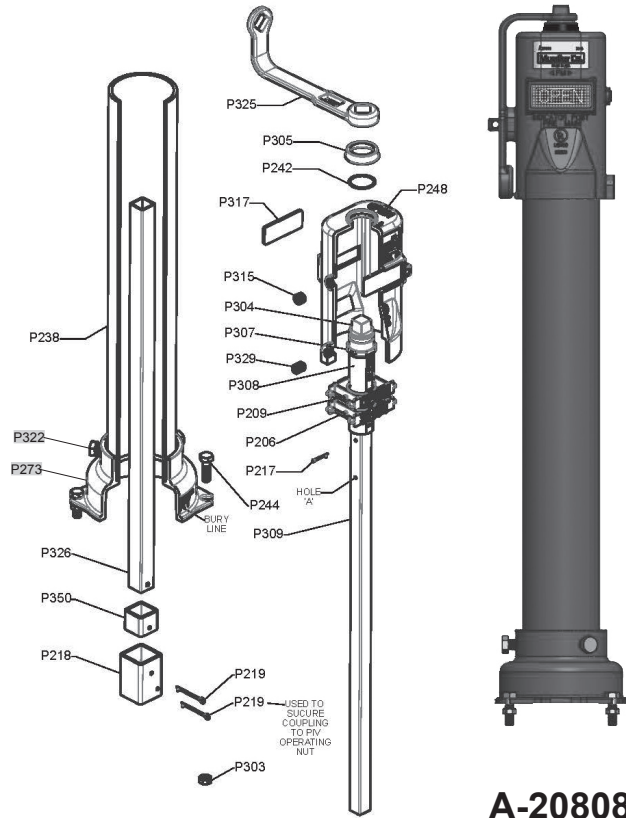

A-20808

MAXIMUM BURY (TRENCH)

Size No.	Valve Size					
	4"	6"	8"	10"	12"	14"
0	1' - 3"	1' - 8"	2' - 1"	2' - 5"	2' - 9"	3' - 3"
1	1' - 9"	2' - 2"	2' - 7"	3' - 11"	3' - 3"	3' - 9"
2	2' - 3"	2' - 8"	3' - 1"	4' - 5"	3' - 9"	4' - 3"

BARREL DIMENSIONS

Size No.	A Dim	B Dim	C Dim
0	26.62	23.62	2"
1	32.62	29.62	7.94"
2	38.62	35.62	13.94"

A-20815: Extension Section and Stem.
Lengths: 1' - 0", 1' - 6", 2' - 0", 2' - 6",
3' - 0", 3' - 6", 4' - 0", 4' - 6", 5' - 0"

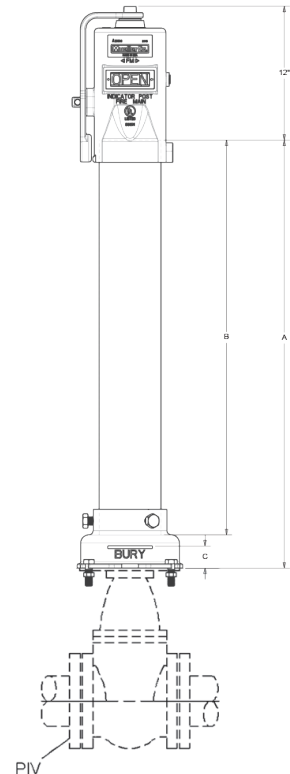
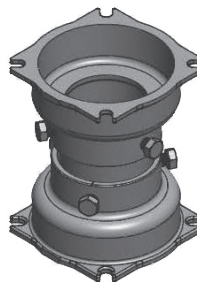

FIRE PROTECTION PRODUCTS

A-20809: Non-Adjustable Indicator Post

UL Listed

PARTS LIST

Catalog Part No.	Description	Material	Material Standard
P206	SHUT Target	Plastic	Nylon
P209	OPEN Target	Plastic	Nylon
P217	Cotter Pin (short)	Brass	ASTM B21
P218	Coupling	Steel	ASTM A500 GR.B
P219	Cotter Pin (long)	Brass	ASTM B21
P238	Barrel	Steel	ASTM A500 GR.B
P242	Retaining Ring	Stainless Steel	AISI 302
P244	Hex Bolt	Steel/zinc plated	ASTM A307 GR.A
P248	Post Head	Cast Iron*	ASTM A126 CL.B
P273	Bell	Ductile Iron	ASTM A536
P303	Hex Nut	Steel/zinc plated	ASTM A563 GR.B
P304	Operating Nut	Ductile Iron	ASTM A536
P305	Cap	Plastic	Polypropylene
P307	Spring pin	Stainless Steel	AISI 420
P308	Threaded sleeve	Plastic	Nylon
P309	Upper stem	Steel	ASTM A513
P315	Pipe plug - hex socket	Steel	-
P317	Window	Polycarbonate	-
P322	Hex HD Screw	Steel/Zinc Plated	SAE J429
P325	Wrench	Steel	ASTM A36 HRS
P326	Lower Stem	Steel	ASTM A500 GR.B
P329	Socket head set screw	Steel	ANSI B18.3
P350	Coupling insert	Steel	ASTM A500 GR.B

* Manufacturers option to change material to Ductile iron ASTM A536

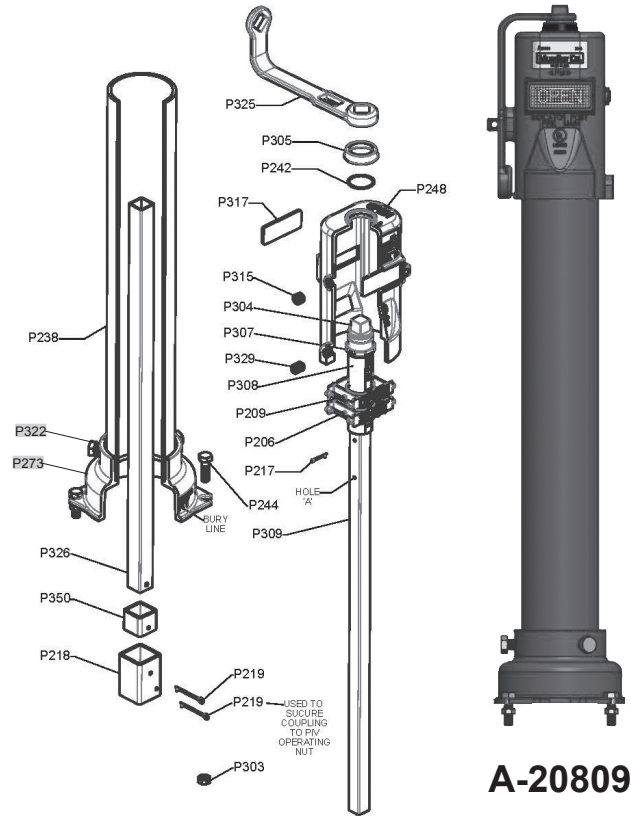

A-20809

MAXIMUM BURY (TRENCH)

Size No.	Valve Size			
	16"	18"	20"	24"
0	3' - 7"	4' - 2"	4' - 6"	5' - 3"
1	4' - 1"	4' - 8"	5' - 0"	5' - 9"
2	4' - 7"	5' - 2"	5' - 6"	6' - 3"

BARREL DIMENSIONS

Size No.	A Dim	B Dim	C Dim
0	26.62	23.62	2"
1	32.62	29.62	7.94"
2	38.62	35.62	13.94"

A-20815: Extension Section and Stem.
Lengths: 1' - 0", 1' - 6", 2' - 0", 2' - 6",
3' - 0", 3' - 6", 4' - 0", 4' - 6", 5' - 0"

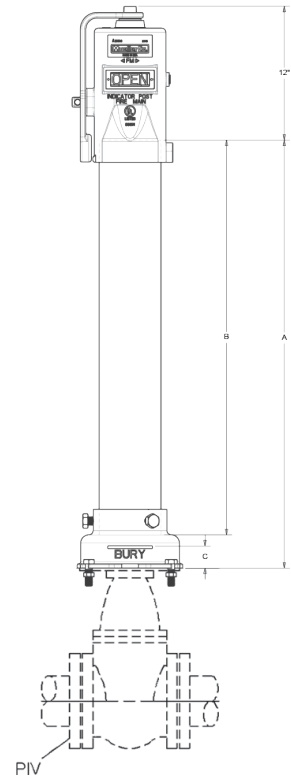
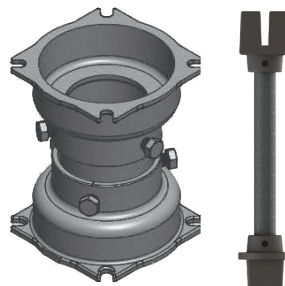

SECTION
E-1

Rev. 10-17

Shaded area indicates change

**SHALLOW BURY
ADJUSTABLE INDICATOR
POST FOR 4" THRU 24" VALVES**



UL / FM

FIRE PROTECTION PRODUCTS

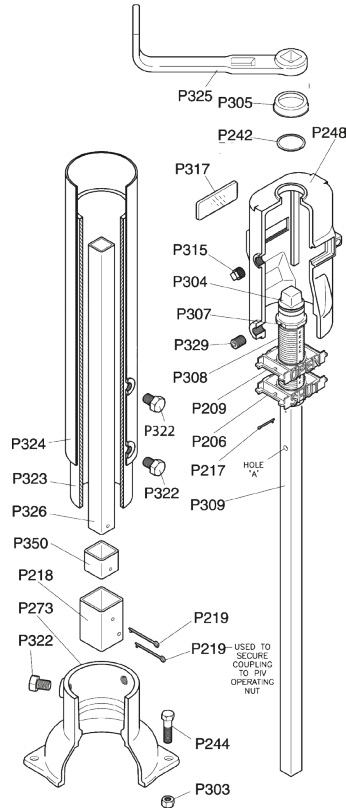

A-20806 & A-20807

A-20806: Adjustable Type Indicator Post

- UL Listed
- FM Approved

A-20807: Adjustable Type Indicator Post

- UL Listed

Parts List

Catalog Part Number	Description	Material	Material Standard
P206	SHUT Target	Plastic	Nylon
P209	OPEN Target	Plastic	Nylon
P217	Cotter Pin (short)	Brass	ASTM B21
P218	Coupling	Steel	ASTM A500 GR.B
P219	Cotter Pin (long)	Brass	ASTM B21
P242	Retaining ring	Stainless Steel	AISI 302
P244	Hex Bolt	Steel/zinc plated	ASTM A307 GR.A
P248	Post Head	Cast Iron**	ASTM A126 CL.B
P273	Bell	Cast Iron	ASTM A126 CL.B
P303	Hex Nut	Steel/zinc plated	ASTM A563 GR.B
P304	Operating Nut	Ductile Iron	ASTM A536 ▼
P305	Cap	Plastic	Polypropylene
P307	Spring pin	Stainless Steel	AISI 420
P308	Threaded sleeve	Plastic	Nylon
P309	Upper stem	Steel	ASTM A513
P315	Pipe plug - hex socket	Steel	-
P317	Window	Polycarbonate	-
P322	Hex head screw	Steel/zinc plated	SAE J429
P323	Lower Barrel	PVC*	DR14 UL Listed
P324	Upper Barrel	Steel	ASTM A53 GR.B
P325 (20806)	Wrench	Ductile Iron	ASTM A536 ▼
P325 (20807)	Wrench	Steel	ASTM A35 HRS
P326	Lower Stem	Steel	ASTM A500 GR.B
P329	Socket head set screw	Steel	ANSI B18.3
P350	Coupling Insert	Steel	ASTM A500 GR.B
P353	Washer	Stainless Steel	AISI 304

* Optional ductile iron lower barrel available

** Manufacturers option to change material to Ductile iron ASTM A536

▼ Material strength ASTM A536 65-45-12 minimum

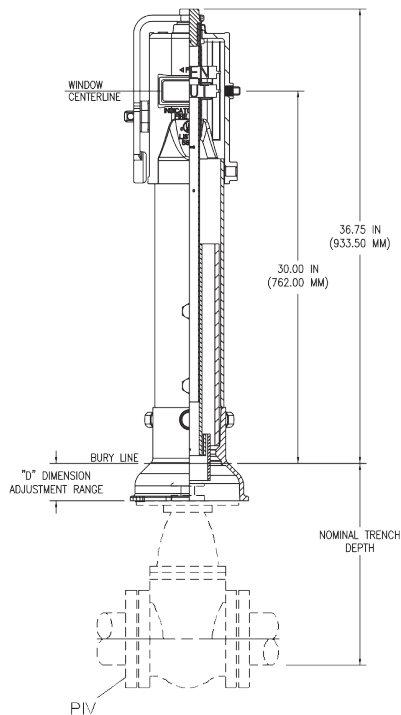

Nominal trench depths for Mueller Resilient Wedge Post Indicator Valves

Part Number	Valve size	Order Length S	
		Minimum	Maximum
A-20806	4"	1' - 4"	2' - 3"
	6"	1' - 9"	2' - 8"
	8"	2' - 1"	3" - 0"
	10"	2' - 6"	3" - 5"
	12"	2' - 10"	3" - 9"
A-20807	14"	3" - 4"	4' - 3"
	16"	3' - 8"	4' - 7"
	18"	4' - 3"	5' - 2"
	20"	4' - 7"	5' - 6"
	24"	5' - 4"	6' - 3"

D Dimension adjustment range

Minimum	Maximum
3"	14"

WALL TYPE INDICATOR POST FOR 4"-16" VALVES



A-20814

A-20814: Wall Type Indicator Post

UL Listed FM Approved

PARTS LIST

Catalog Part No.	Description	Material	Material Standard
P206	Target Shut	Plastic	Nylon
P209	Target Open	Plastic	Nylon
P217	Cotter Pin (short)	Brass	ASTM B21
P218	Coupling	Steel	ASTM A500 GR.B
P219	Cotter Pin (long)	Brass	ASTM B21
P242	Retaining ring	Stainless Steel	AISI 302
P272	Washer	Steel/zinc plated	
P300	Eye Bolt	Steel/zinc plated	
P301	Hex Nut	Steel/zinc plated	ASTM A563 GR.B
P302	Handwheel	Ductile Iron	ASTM A536
P304	Operating Nut	Ductile Iron	ASTM A536
P305	Cap	Plastic	Polypropylene
P307	Spring pin	Stainless Steel	AISI 420
P308	Threaded sleeve	Plastic	Nylon
P309	Upper stem	Steel	ASTM A513
P315	Pipe plug - hex socket	Steel	
P316	Post head	Cast Iron**	ASTM A126 CL.B
P317	Window	Polycarbonate	
P326	Lower Stem	Steel	ASTM A500 GR.B
P329	Socket head set screw	Steel	ANSI B18.3
P350	Coupling insert	Steel	ASTM A500 GR.B
P353	Washer*	Stainless Steel	AISI 304
P354	Indicator Post Cover	Cast Iron	ASTM A126 CL.B
P355	Hex Nut 1/2"	Steel/zinc plated	ASTM A563 GR.B
P356	Hex Bolt 1/2"x1-3/4"	Steel/zinc plated	ANSI B18.2.1

* Washer use discontinued in 2011. Not required when P305 cap is used.

** Manufacturers option to change material to Ductile iron ASTM A536

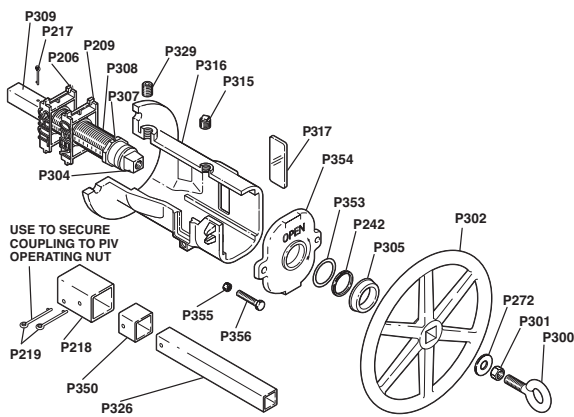

USE TO SECURE COUPLING TO PIV OPERATING NUT

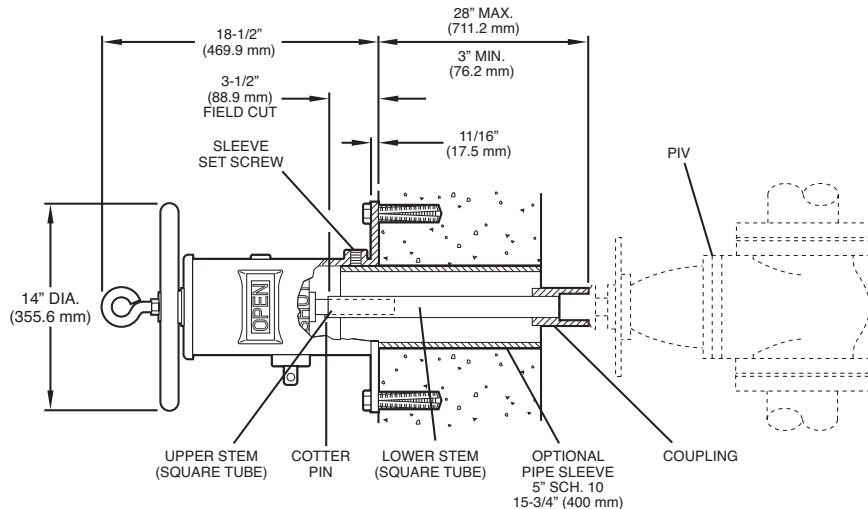
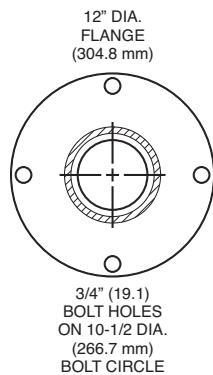

**ADJUSTABLE
INDICATOR POST
REPLACEMENT PARTS**

Replacement parts for A-20801: UL/FM Indicators Posts manufactured from 1991 - 1999.

PARTS LIST

Catalog Part No.	Description	Material	Material Standard
P6	Target Sign Plate (SHUT)	Nylon	-
P9	Target Sign Plate (OPEN)	Nylon	-
P17	Cotter Pin (short)	Brass	ASTM B21
P18	Coupling	Steel	ASTM A500 GR.B
P19	Cotter Pin (long)	Brass	ASTM B21
P42	Retaining Ring	Stainless Steel	AISI 302
P44	Hex Bolt (not shown)	Steel/Zinc Plated	ASTM A307 GR.A
P45	Hex Bolt for Cap	Steel/Galvanized	ANSI B18.2.1
P49	Washer	Steel/Zinc Plated	-
P103	Hex Nut for Cap Bolts	Steel/Galvanized	ANSI B18.2.1
P104	Opening Nut	Ductile Iron	ASTM A536
P105	Cap	Cast Iron	Class B
P107	Groove Pin	Silicon Bronze	ASTM B124
P108	Threaded Sleeve	Nylon	-
P109	Upper Stem	Steel	ASTM A108 C101B
P110	Target Half	Nylon	-
P111	Target Screw	Steel/Zinc Plated	-
P112	Target Bushing	Nylon	-
P113	Stove Bolt (short)	Steel/Galvanized	ASTM A164 Type RS
P114	Nut for "open" and "shut" Sign	Steel	-
P115	Pipe Plug (hex socket)	Steel	-
P116	Post Head	Cast Iron	Class B
P117	Window	Plexiglass	-
P121	Stove Bolt (long)	Steel/Galvanized	ASTM A164 Type RS
P122	Hex Head Screw	Steel	ANSI B18.2.1
P123	Lower Barrel	Ductile Iron	Class 5.1
P124	Upper Barrel	Carbon Steel	Grade A or B
P125	Wrench	Ductile Iron	ASTM A536
P126	Adjustable Stem	Steel Tubing	ASTM A500 GR.B
P127	Name Plate	Polyester Fill	-
P129	Spline Head Set Screw	Steel	ANSI B18.3

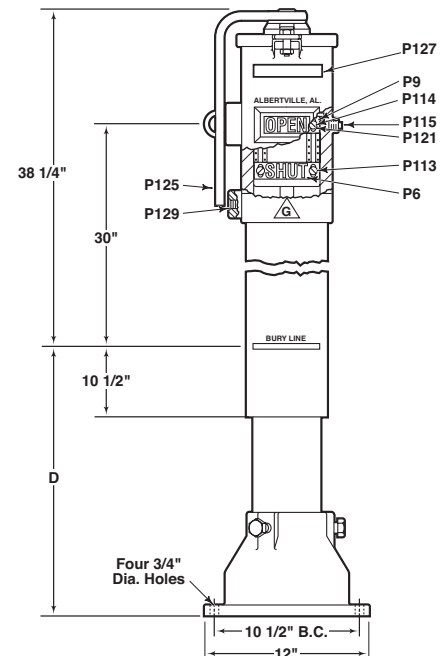
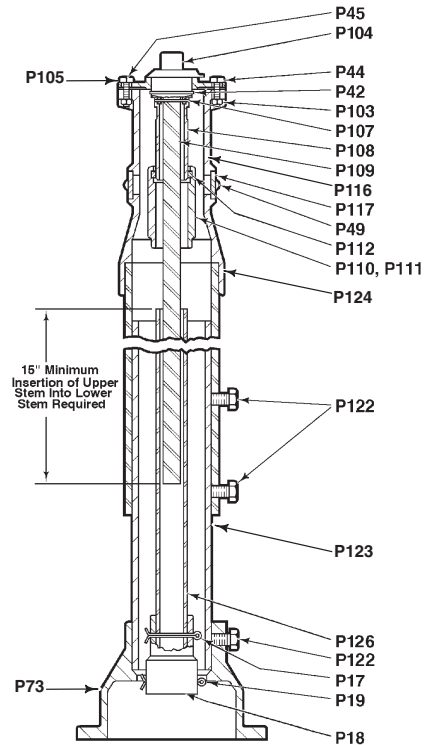

Replacement parts for A-20800 UL/FM Indicators Posts manufactured from 1983 - 1985.

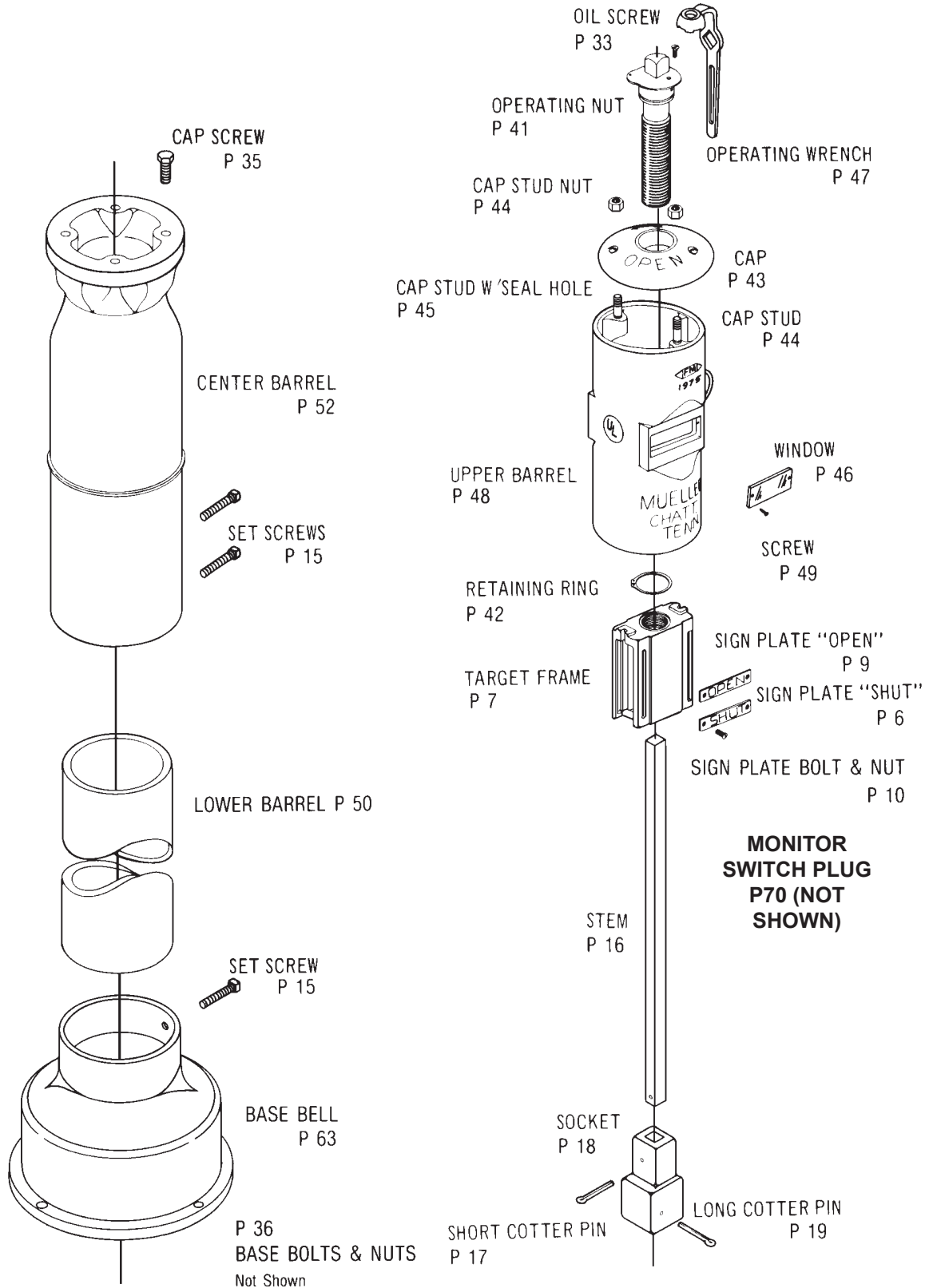

**ADJUSTABLE
INDICATOR POST
REPLACEMENT PARTS**



UL / FM

FIRE PROTECTION PRODUCTS

Replacement parts for A-20800: UL/FM Indicators Posts manufactured from 1972 - 1982.

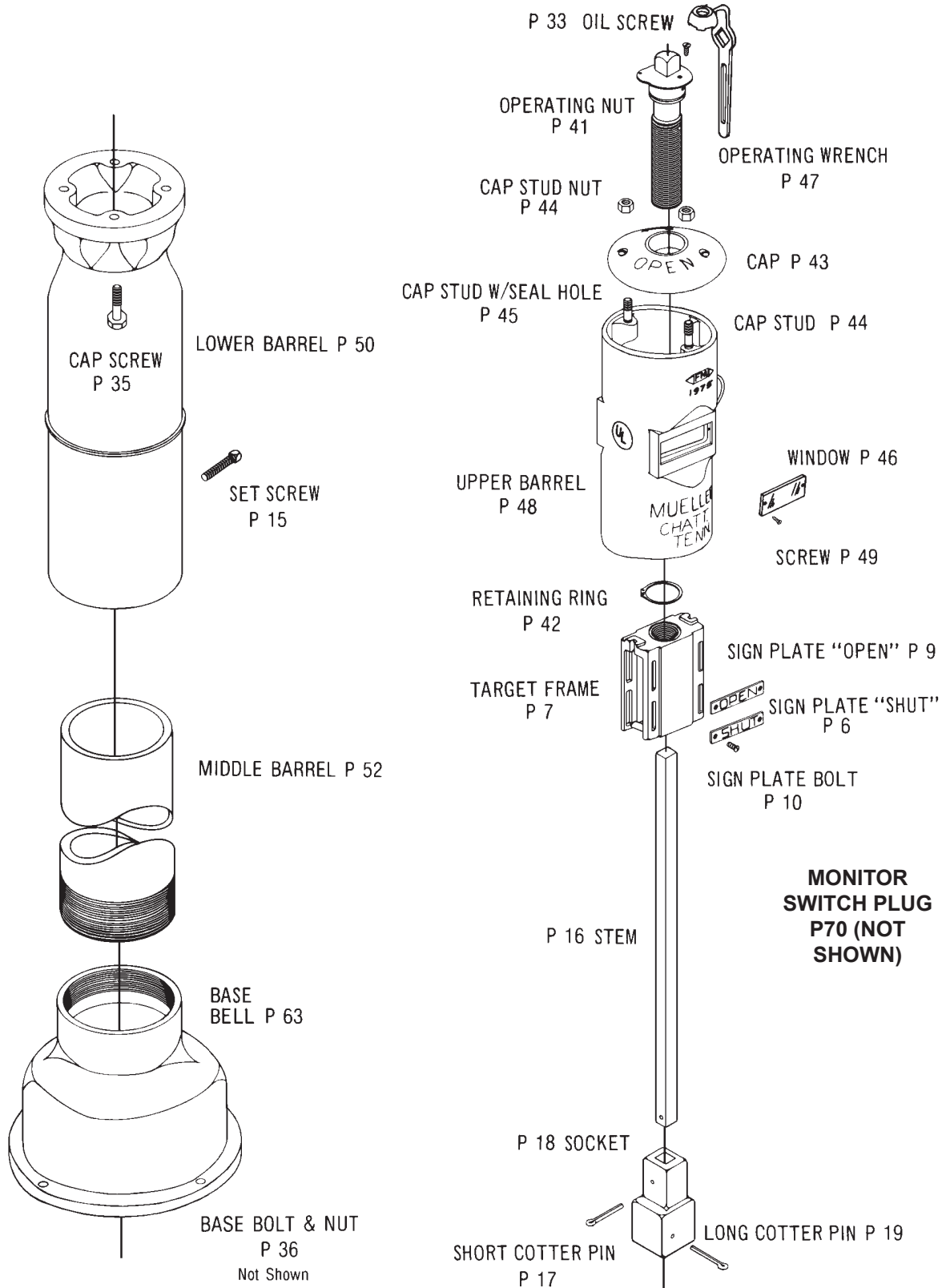

Replacement parts for A-20805: UL/FM Indicators Posts manufactured from 1986 - 1999.

Catalog Part No.	Description	Material	Material Standard
P6	Target Sign Plate (SHUT)	Nylon	-
P7	Target Fram with Bushing and Screws	-	-
P9	Target Sign Plate (OPEN)	Plastic	-
P10	Sign Plate Bolt and Nut	Steel	ASTM A307 CL.B
P17	Cotter Pin (short)	Brass	ASTM B21
P18	Socket	Cast Iron	ASTM A126 CL.B
P19	Cotter Pin (long)	Brass	ASTM B21
P33	Oil Screw	Bronze	-
P35	Cap Screw	Steel	ASTM A307 CL.B
P36	Base Bolt and Nut	Steel	ASTM A307 CL.B
P38	Lower Barrel	Cast Iron	ASTM A126 CL.B
P41	Wrench Nut	Bronze	ASTM B62
P42	Retaining Ring	Stainless Steel	SAE 1065-1090
P43	Cap	Cast Iron	ASTM A126 CL.B
P44	Hex Bolt	Steel / Galvanized	ASTM A164 Type RS
P45	Hex Bolt with Hold in Head	Steel / Galvanized	ASTM A164 Type RS
P46	Window	Plexiglass	-
P47	Wrench	Ductile Iron	ASTM A536
P49	Screw for Window	Bronze	ASTM B21 Alloy 464
P62	Stem	Steel	ASTM A36
P70	1" Monitor Switch Plug	Malleable Iron	-

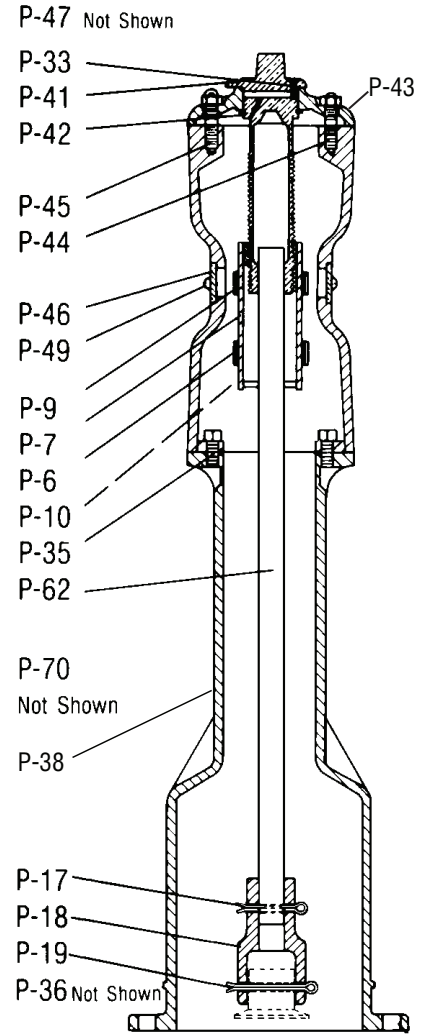

**NON-ADJUSTABLE
INDICATOR POST
REPLACEMENT PARTS**



Replacement parts for A-20805: UL/FM Indicators Posts manufactured from 1983 - 1985.

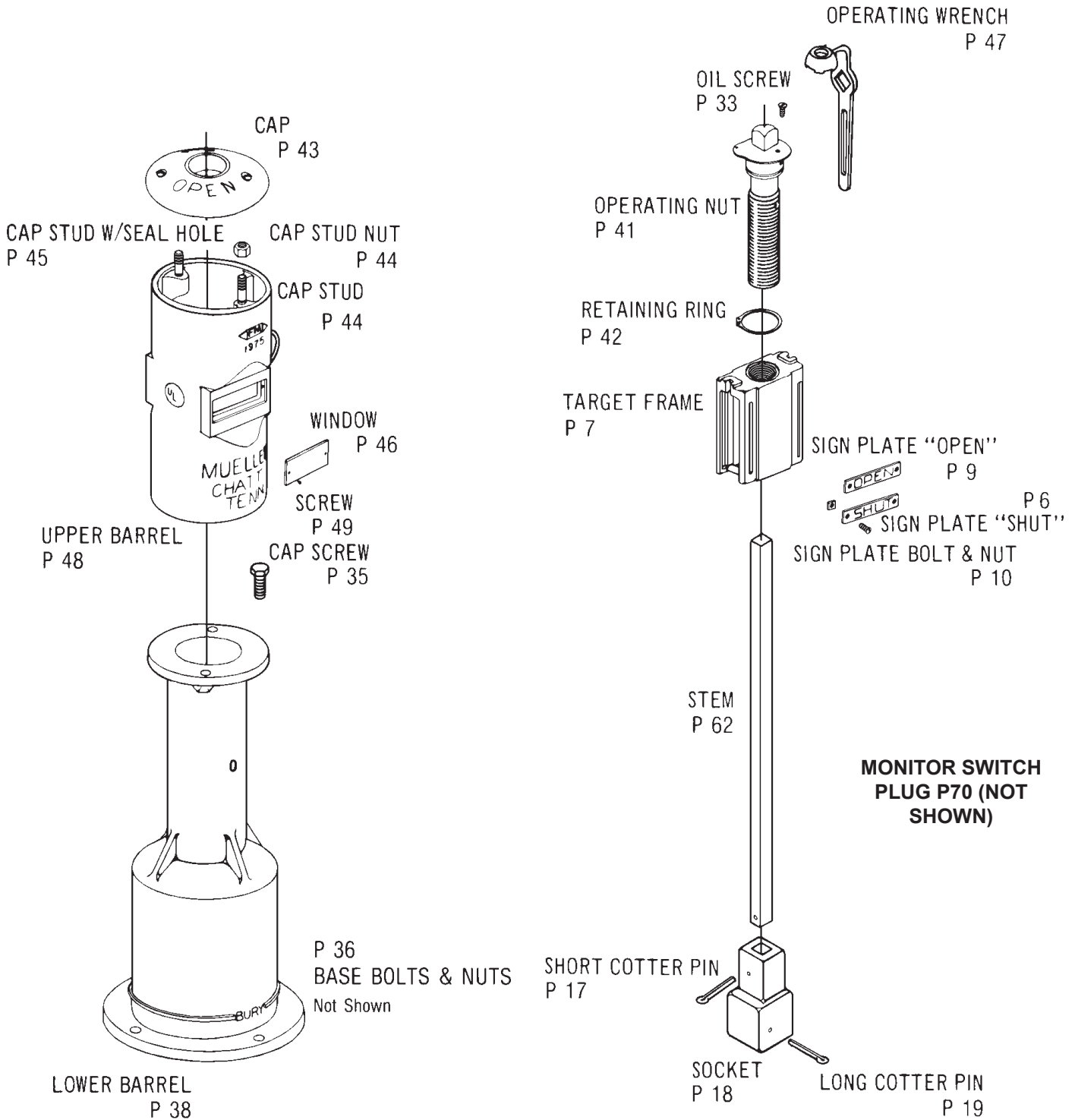

Replacement parts for A-20805 UL/FM Indicators Posts manufactured from 1972 - 1982.

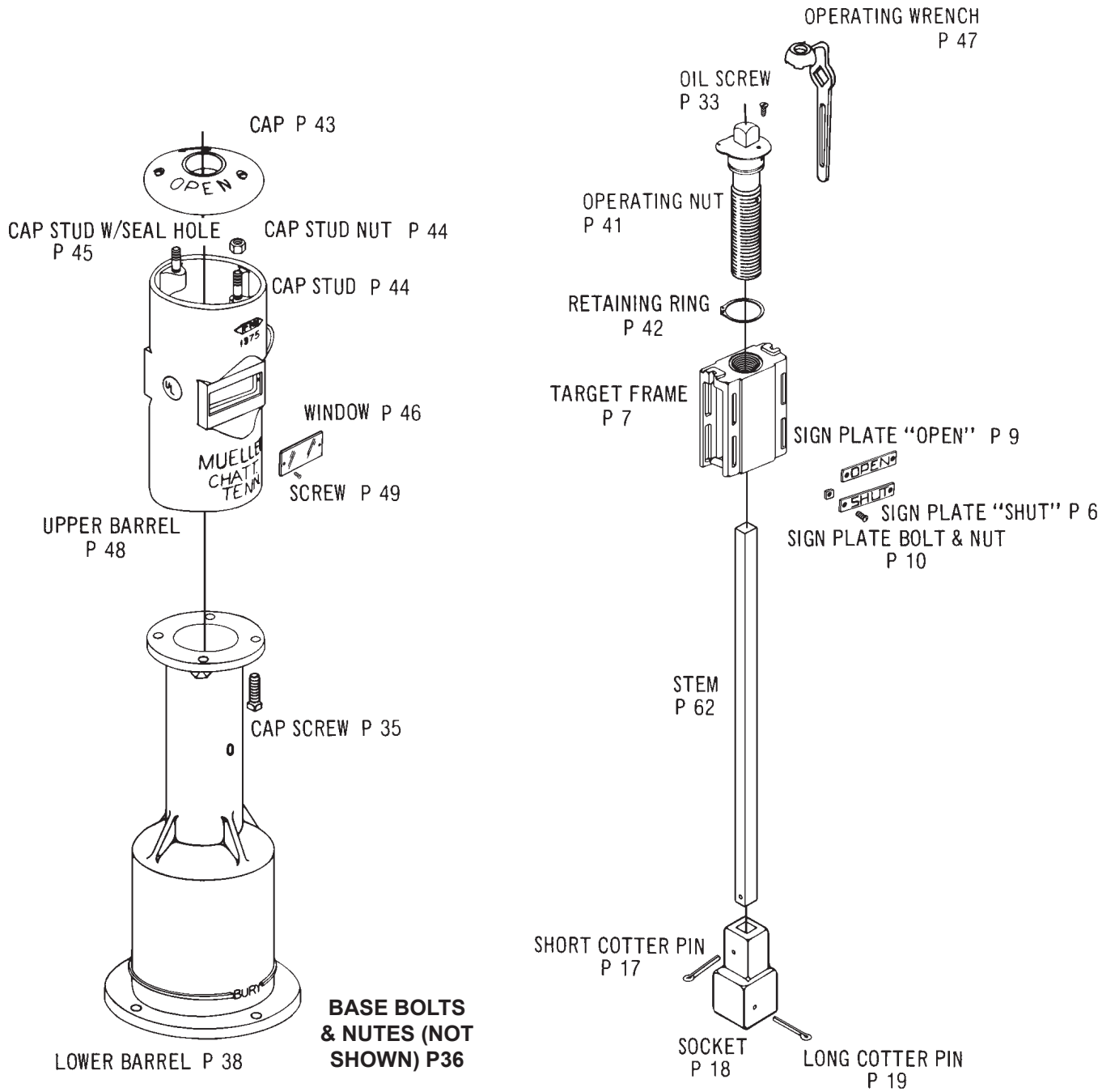

**WALL TYPE
INDICATOR POST
REPLACEMENT PARTS**

Replacement parts for A-20811: UL/FM Indicators Posts manufactured from 1991 - 1999.

Catalog Part No.	Description	Material	Material Standard
P6	Target Sign Plate (SHUT)	Nylon	-
P9	Target Sign Plate (OPEN)	Plastic	-
P17	Cotter Pin (short)	Brass	ASTM B21
P18	Socket	Cast Iron	ASTM A126 CL.B
P19	Cotter Pin (long)	Brass	ASTM B21
P42	Retaining Ring	Stainless Steel	SAE 1065 - 1090
P44	Hex Bolt	Steel/Galvanized	ASTM A164 Type RS
P45	Hex Bolt with Hole in Head	Steel/Galvanized	ASTM A164 Type RS
P49	Screw	Brass	ASTM B21
P72	Washer	Steel/Zinc Plated	-
P100	Eyebolt	Steel/Zinc Plated	-
P101	Hex Nut	Steel/Zinc Plated	ANSI B18.2.2
P102	Handwheel	Cast Iron	ASTM A126 CL.B
P103	Hex Nut	Steel/Galvanized	ASTM A164 Type RS
P104	Operating Ring	Ductile Iron	ASTM A536
P105	Cap	Cast Iron	ASTM A126 CL.B
P107	Groove Pin	Silicon Bronze	ASTM B124
P108	Thread Sleeve	Nylon	-
P109	Upper Stem	Steel	ASTM A108 C101B
P110	Target Half	Nylon	-
P111	Target Screw (not shown)	Steel/Zinc Plated	-
P112	Target Bushing	Nylon	-
P113	Stove Bolt (short)	Steel/Galvanized	ASTM A164 Type RS
P114	Nut for "open" and "shut"	Steel	ANSI B.18.2.2
P115	Pipe Plug - hex stock	Steel	-
P117	Window	Plexiglass	-
P118	Lower Stem	Steel Tubing	ASTM A500 GR.B
P119	Name Plate	Polyester fill	-
P121	Stove Bolt (long)	Steel/Galvanized	ASTM A164 Type RS
P128	Post Head	Cast Iron	ASTM A126 CL.B

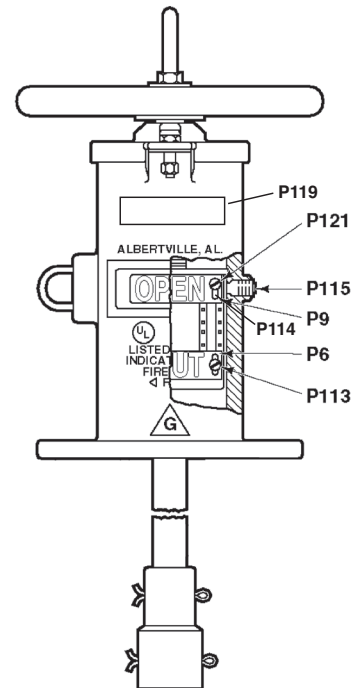
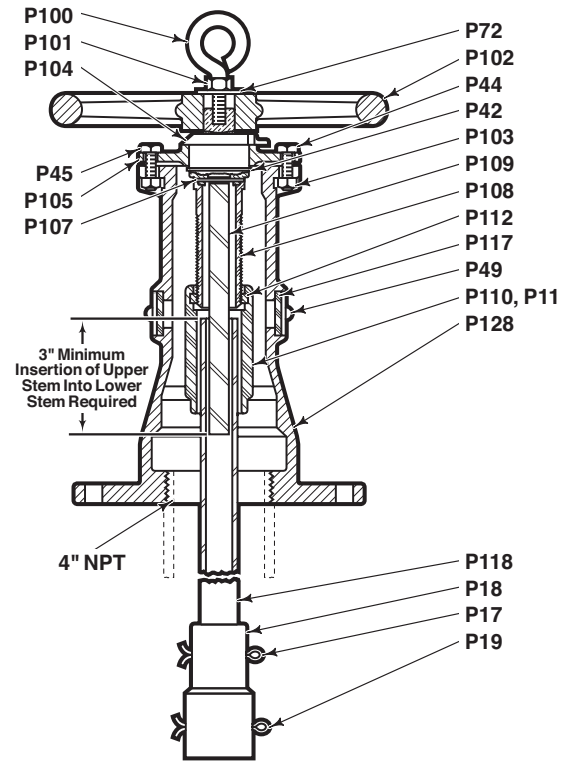

Replacement parts for A-20810 UL/FM Indicators Posts manufactured from 1983 - 1990.

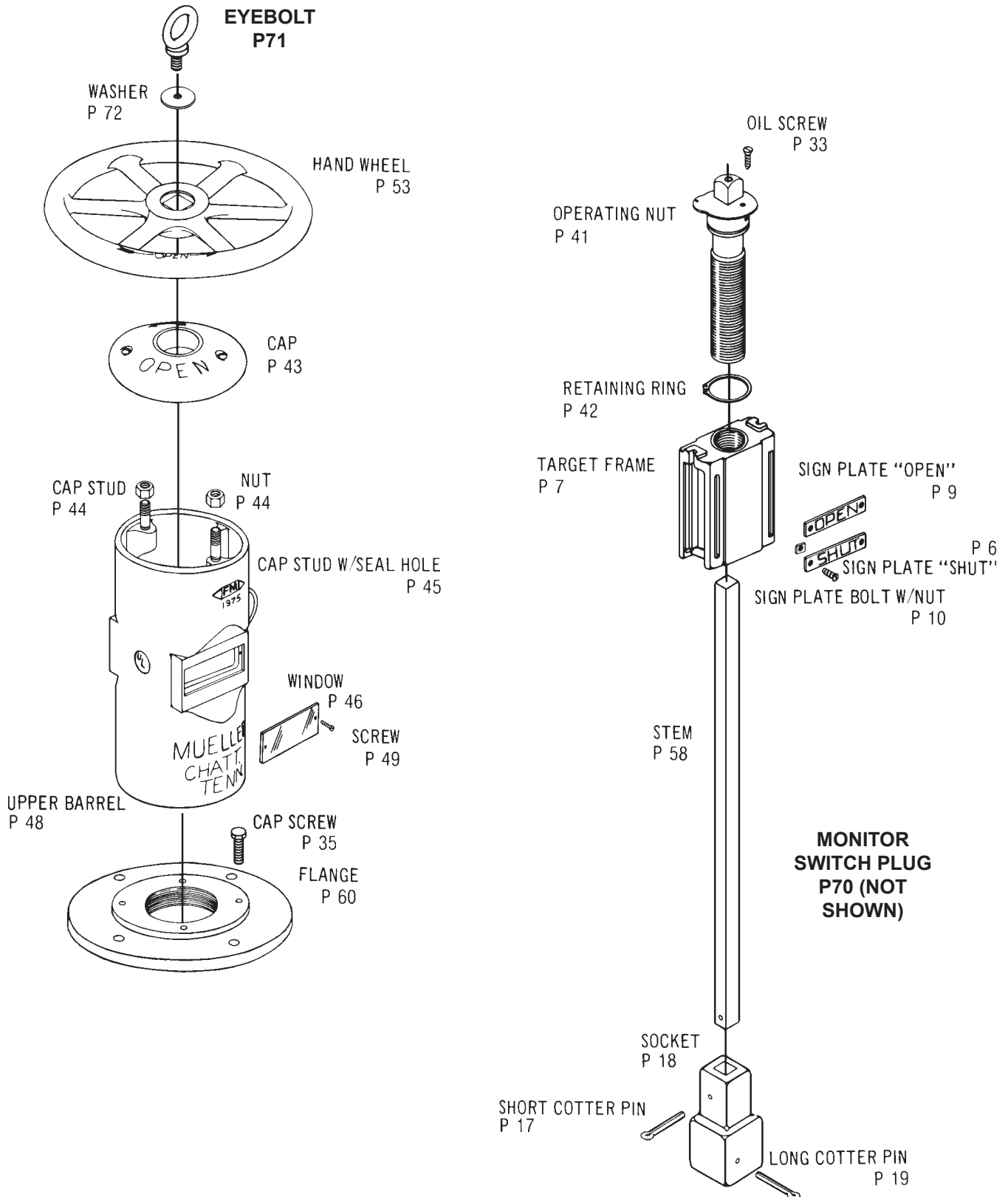

**WALL TYPE
INDICATOR POST
REPLACEMENT PARTS**

Replacement parts for A-20810: UL/FM Indicators Posts manufactured from 1972 - 1982.

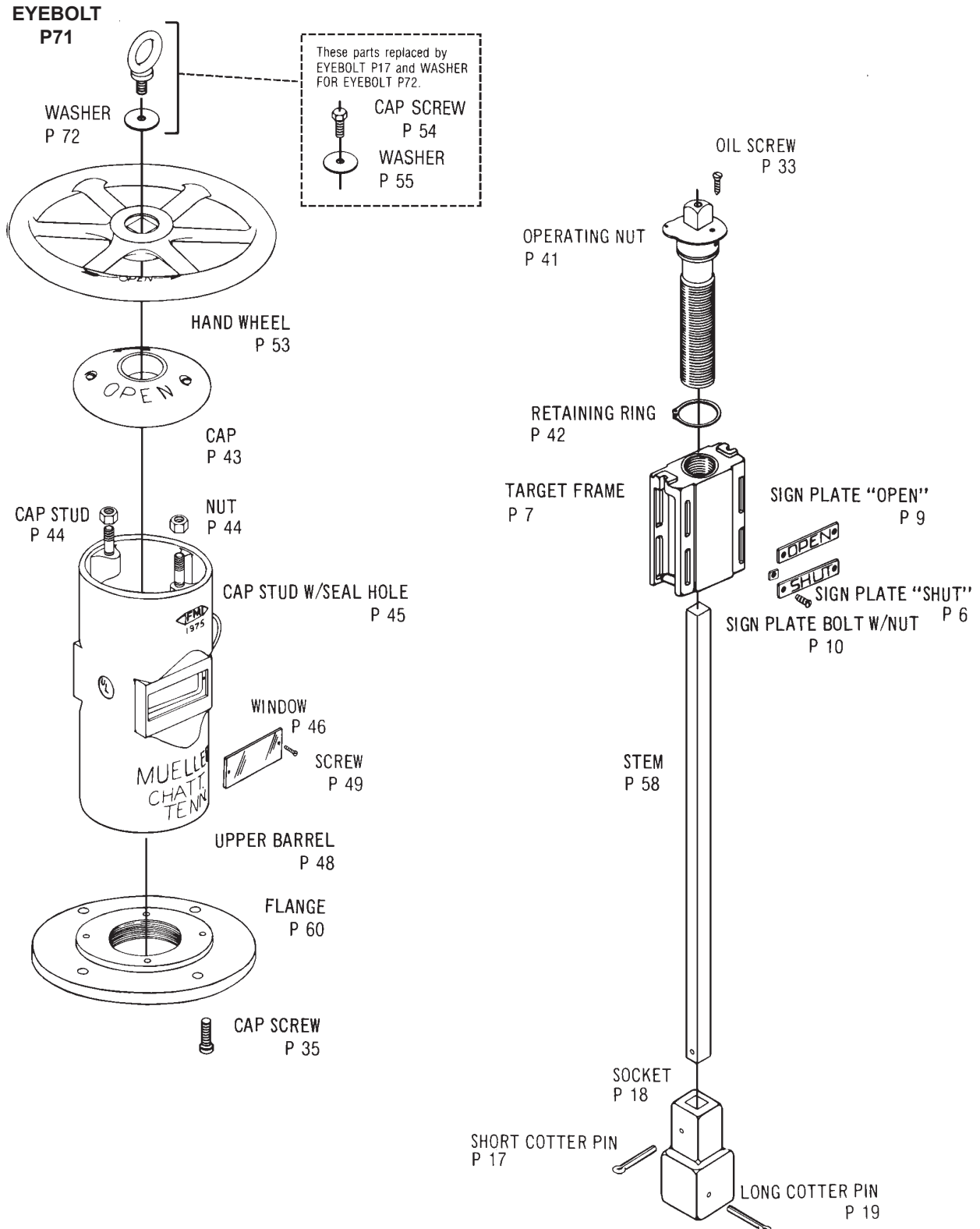

A-20806/A-20807 Adjustable Indicator Post

To order specify:

Quantity, catalog number including lower barrel designation (A, B, C, D, or E), valve size, direction of opening, and size and shape of operating nut (1-1/4" square is standard and will be furnished unless otherwise specified).

A-20808/A-20809 Non-Adjustable Indicator Post

To order specify:

Quantity, catalog number including lower barrel designation (0, 1 or 2), valve size, direction of opening, and size and shape of operating nut (1-1/4" square is standard and will be furnished unless otherwise specified).

A-20814 Wall Type Indicator Post

To order specify:

Quantity, catalog number, valve size, and direction of opening. Handwheel is standard on Wall Type Indicator Posts.

Replacement Parts

To order specify:

Quantity, catalog number, part number, part name, catalog number of post, year date on post and size or lower barrel designation of post.

SECTION
E-1

Rev. 9-17

Shaded area indicates change

**ADJUSTABLE
INDICATOR POST
FOR 4" THRU 14" VALVES**
ULC LISTED, FM APPROVED



UL / FM

FIRE PROTECTION PRODUCTS

C-20806

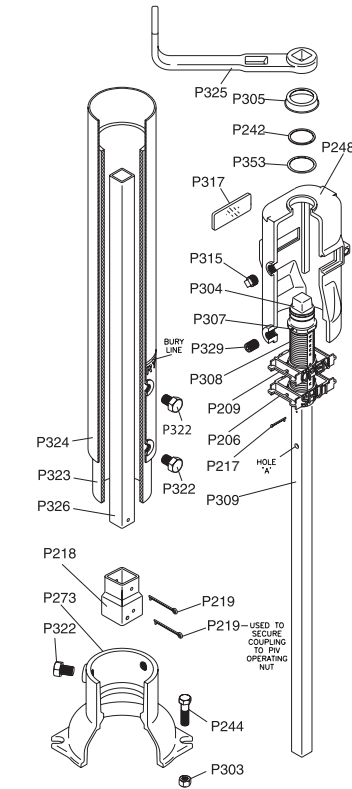

Catalog Part No.	Description	Material	Material Standard
P206	SHUT Target	Plastic	Nylon
P209	OPEN Target	Plastic	Nylon
P217	Cotter Pin (short)	Brass	ASTM B21
P218	Coupling	Cast Iron	ASTM A126 Class B
P219	Cotter Pin (long)	Brass	ASTM B21
P242	Retaining ring	Stainless Steel	AISI 302
P244	Hex Bolt	Stainless Steel	AISI 304
P248	Post Head	Cast Iron*	ASTM A536 GR.65-45-12
P273	Bell	Cast Iron	ASTM A126 CL.B
P303	Hex Nut	Stainless Steel	AISI 304
P304	Operating Nut	Ductile Iron	ASTM A536 GR.65-45-12
P305	Cap	Plastic	Polypropylene
P307	Spring pin	Stainless Steel	AISI 420
P308	Threaded sleeve	Plastic	Nylon
P309	Upper stem	Steel	ASTM A513
P315	Pipe plug - hex socket	Steel	
P317	Window	Polycarbonate	
P322	Hex head screw	Stainless Steel	AISI 304
P323	Lower Barrel	Ductile Iron	ASTM A746 Class 51
P324	Upper Barrel	Steel	ASTM A53 GR.B
P325	Wrench	Ductile Iron	ASTM A536 GR.5-45-12
P326	Lower Stem	Steel	ASTM A500 GR.B
P329	Socket head set screw	Steel	ANSI B18.3
P353	Washer**	Stainless Steel	AISI 304

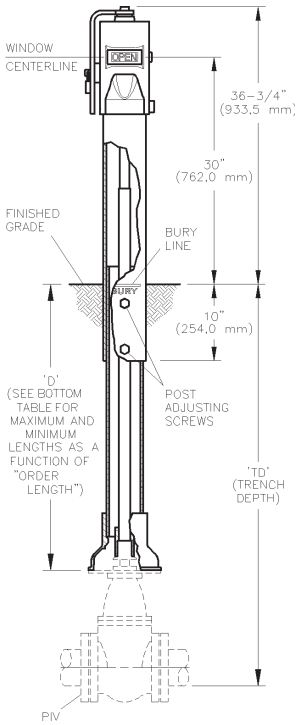

Nominal trench depths

* Manufacturers option to change material to Ductile iron ASTM A536
** Washer use discontinued in 2011. Not required when P305 cap is used.

Valve Size	"ORDER LENGTH" A		"ORDER LENGTH" B		"ORDER LENGTH" C		"ORDER LENGTH" D		"ORDER LENGTH" E	
	Min.	Max.	Min.	Max.	Min.	Max.	Min.	Max.	Min.	Max.
4"	3' - 0"	4' - 10"	4' - 6"	6' - 7"	6' - 3"	8' - 4"	8' - 0"	10' - 1"	9' - 9"	11' - 7"
6"	3' - 5"	5' - 3"	4' - 11"	7' - 0"	6' - 8"	8' - 9"	8' - 5"	10' - 6"	10' - 2"	12' - 0"
8"	3' - 9"	5' - 7"	5' - 4"	7' - 4"	7' - 1"	9' - 1"	8' - 10"	10' - 10"	10' - 7"	12' - 4"
10"	4' - 1"	5' - 11"	5' - 8"	7' - 8"	7' - 5"	9' - 5"	9' - 2"	11' - 2"	10' - 11"	12' - 8"
12"	4' - 5"	6' - 3"	6' - 0"	8' - 0"	7' - 9"	9' - 9"	9' - 6"	11' - 6"	11' - 3"	13' - 0"
14"	4' - 11"	6' - 9"	6' - 6"	8' - 6"	8' - 3"	10' - 3"	10' - 0"	12' - 0"	11' - 9"	13' - 6"

Valve Size	"ORDER LENGTH" F		"ORDER LENGTH" G		"ORDER LENGTH" H		"ORDER LENGTH" I	
	Min.	Max.	Min.	Max.	Min.	Max.	Min.	Max.
4"	11' - 6"	13' - 7"	13' - 8"	15' - 9"	15' - 4"	17' - 5"	17' - 0"	19' - 1"
6"	11' - 11"	14' - 0"	14' - 1"	16' - 2"	15' - 9"	17' - 10"	17' - 5"	19' - 6"
8"	12' - 4"	14' - 4"	14' - 6"	16' - 6"	16' - 4"	18' - 2"	17' - 10"	19' - 10"
10"	12' - 8"	14' - 8"	14' - 10"	16' - 10"	16' - 8"	18' - 6"	18' - 2"	20' - 2"
12"	13' - 0"	15' - 0"	15' - 2"	17' - 2"	17' - 0"	18' - 10"	18' - 6"	20' - 6"
14"	13' - 6"	15' - 6"	15' - 8"	17' - 8"	17' - 4"	19' - 4"	19' - 0"	21' - 0"

"D" Dimension adjustment range

	"ORDER LENGTH"								
	A	B	C	D	E	F	G	H	I
MIN	22.25"	41.00"	62.00"	83.00"	104.00"	125.00"	151.00"	171.00"	191.00"
MAX	44.25"	65.25"	86.25"	107.25"	125.25"	149.25"	175.25"	195.25"	215.25"

FIRE PROTECTION PRODUCTS

ADJUSTABLE INDICATOR POST FOR 16" THRU 24" VALVES

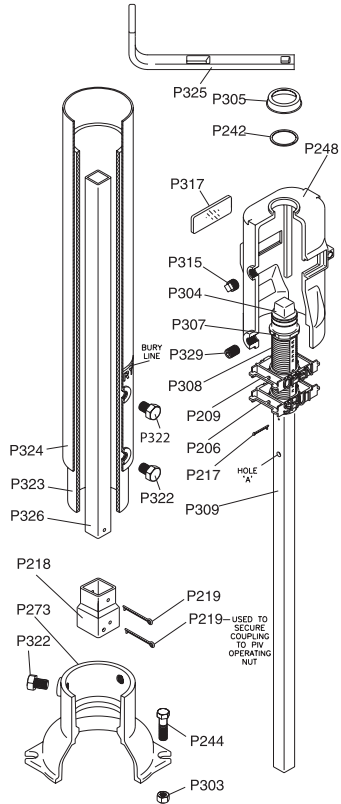
C-20807

Catalog Part No.	Description	Material	Material Standard
P206	SHUT Target	Plastic	Nylon
P209	OPEN Target	Plastic	Nylon
P217	Cotter Pin (short)	Brass	ASTM B21
P218	Coupling	Cast Iron	ASTM A126 Class B
P219	Cotter Pin (long)	Brass	ASTM B21
P242	Retaining ring	Stainless Steel	AISI 302
P244	Hex Bolt	Stainless Steel	AISI 304
P248	Post Head	Cast Iron*	ASTM A536 GR.65-45-12
P273	Bell	Cast Iron	ASTM A126 CL.B
P303	Hex Nut	Stainless Steel	AISI 304
P304	Operating Nut	Ductile Iron	ASTM A536 GR.65-45-12
P305	Cap	Plastic	Polypropylene
P307	Spring pin	Stainless Steel	AISI 420
P308	Threaded sleeve	Plastic	Nylon
P309	Upper stem	Steel	ASTM A513
P315	Pipe plug - hex socket	Steel	-
P317	Window	Polycarbonate	-
P322	Hex head screw	Stainless Steel	AISI 304
P323	Lower Barrel	Ductile Iron	ASTM A746 Class 51
P324	Upper Barrel	Steel	ASTM A53 GR.B
P325	Wrench	Steel	ASTM A35 HRS
P326	Lower Stem	Steel	ASTM A500 GR.B
P329	Socket head set screw	Steel	ANSI B18.3

* Manufacturers option to change material to Ductile iron ASTM A536

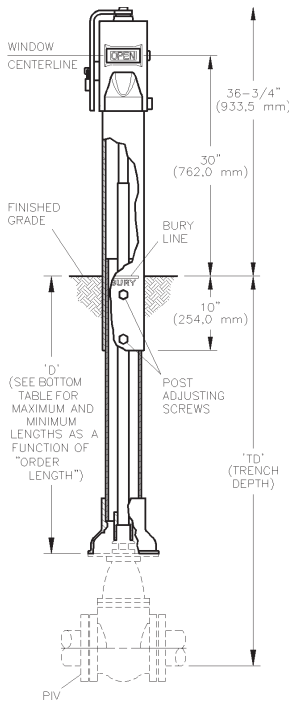

Nominal trench depths

Valve Size	"ORDER LENGTH" A		"ORDER LENGTH" B		"ORDER LENGTH" C		"ORDER LENGTH" D		"ORDER LENGTH" E	
	Min.	Max.	Min.	Max.	Min.	Max.	Min.	Max.	Min.	Max.
16"	5' - 3"	7' - 1"	6' - 10"	8' - 10"	8' - 7"	10' - 7"	10' - 2"	15' - 9"	12' - 1"	13' - 10"
18"	5' - 10"	7' - 8"	7' - 5"	9' - 5"	9' - 2"	11' - 2"	10' - 11"	16' - 11"	12' - 8"	14' - 5"
20"	6' - 3"	8' - 1"	7' - 9"	9' - 10"	9' - 6"	11' - 7"	11' - 3"	17' - 8"	13' - 0"	14' - 10"
24"	6' - 11"	8' - 9"	8' - 6"	10' - 6"	10' - 3"	12' - 3"	12' - 0"	19' - 2"	13' - 9"	15' - 6"

Valve Size	"ORDER LENGTH" F		"ORDER LENGTH" G		"ORDER LENGTH" H		"ORDER LENGTH" I	
	Min.	Max.	Min.	Max.	Min.	Max.	Min.	Max.
16"	13' - 10"	15' - 10"	16' - 0"	18' - 0"	17' - 8"	19' - 8"	19' - 4"	21' - 4"
18"	14' - 5"	16' - 5"	16' - 7"	18' - 7"	18' - 3"	20' - 3"	19' - 11"	21' - 11"
20"	14' - 9"	16' - 10"	16' - 11"	19' - 0"	18' - 7"	20' - 8"	20' - 3"	22' - 4"
24"	15' - 6"	17' - 6"	17' - 8"	19' - 8"	19' - 4"	21' - 4"	21' - 0"	23' - 0"

"D" Dimension adjustment range

	"ORDER LENGTH"								
	A	B	C	D	E	F	G	H	I
MIN	22.25"	41.00"	62.00"	83.00"	104.00"	125.00"	151.00"	171.00"	191.00"
MAX	44.25"	65.25"	86.25"	107.25"	125.25"	149.25"	175.25"	195.25"	215.25"

**ORDERING
INSTRUCTIONS****A-20806/A-20807 Adjustable Indicator Post***To order specify:*

Quantity, catalog number including lower barrel designation (A, B, C, D, or E), valve size, direction of opening, and size and shape of operating nut (1-1/4" square is standard and will be furnished unless otherwise specified).

A-20808/A-20809 Non-Adjustable Indicator Post*To order specify:*

Quantity, catalog number including lower barrel designation (0, 1 or 2), valve size, direction of opening, and size and shape of operating nut (1-1/4" square is standard and will be furnished unless otherwise specified).

A-20814 Wall Type Indicator Post*To order specify:*

Quantity, catalog number, valve size, and direction of opening. Handwheel is standard on Wall Type Indicator Posts.

Replacement Parts*To order specify:*

Quantity, catalog number, part number, part name, catalog number of post, year date on post and size or lower barrel designation of post.

C-20806 and C-20807 Adjustable Indicator Post*To order specify:*

Quantity, catalog number including lower barrel designation (A, B, C, D, E, F, G, H, or I), valve size, direction of opening, and size and shape of operating nut (1-1/4" square is standard and will be furnished unless otherwise specified).

C-20806-WT and C-20807-WT Water Tight Adjustable Indicator Post*To order specify:*

Quantity, catalog number including lower barrel designation (A, B, C, D, E, F, G, H, or I), valve size, direction of opening, and size and shape of operating nut (1-1/4" square is standard and will be furnished unless otherwise specified).

A-20815: Extension Section and Stem*To order specify:*

Quantity and length.