

# Minebea Intec Contego-Hygienic Weigh Module Kits

Lateral Cable Outlet

The protective cover made of FDA-compliant silicone ensures a reliable encapsulation of the module and prevents the intrusion of dirt and microorganisms. The connecting geometry between protective cover and mounting plates guarantees a safe fitting and, together with the already excellent resistance to aging of the silicone, ensures reliable protection over years.

The Contego® weighing module therefore represents an absolutely hygienic unity of load cell and installation kit. As a result, you can refrain from using other expensive and complicated constructions to protect the weighing technology against dirt.

Besides the hygienic aspect, the Contego weighing module provides all the other important mechatronic functions for a fast operational startup and reliable results. The integrated constraint holds the process vessel in the proper position and, at the same time, allows movement through thermal expansion of the vessel. The integrated lift-off protector is a reliable safety feature to protect the vessel from tilting. At the same time, this feature can be used as a lifting system as well. This way, the vessel leg can be raised a few millimeters without using supplemental tools.

A PR6241 S-type load cell is used with this module. This series is distinguished by its unmatched reliability, robustness and stability, enabling years of undisturbed usage without any readjustment, in addition to the high measuring accuracy and reproducibility.



Junction Box not shown

## Standard Features

- Compact and absolute hygienic weighing solution for a load range up to 2t
- Quick and seamless installation
- Easy cleaning without residue
- High chemical resistance
- Protective cover made of FDA-compliant silicone
- Integrated S-like lift-off protector and jack-up function with constrainer for horizontal forces
- Proven rocker pin principle for accurate repeatability
- 10,000 divisions
- Load cell, 2 mV/V
- 15-year load cell warranty
- 30 kN destructive lateral force and 8 kN permissible lift-off protection

## LOAD CELL CERTIFICATIONS



## Options/Accessories

Part #	Type	Minebea Part #	Description	Price
160438	PR6041/80S	9405 360 41802	Bottom plate, tank leg connection	\$371.00

## Lateral Cable Outlet Options

Total Capacity	Load Cell Capacity	RLWS Part #	Minebea Part #	Price
<b>3-Module Kit</b>				
660 lb	300 kg	220 lb	100 kg	<b>158832</b> CTG-332A-U \$8,601.50
1,300 lb	600 kg	440 lb	200 kg	<b>158834</b> CTG-632A-U \$8,601.50
1,900 lb	900 kg	660 lb	300 kg	<b>158892</b> CTG-932A-U \$8,601.50
3,300 lb	1500 kg	1,100 lb	500 kg	<b>158837</b> CTG-1532A-U \$8,601.50
6,600 lb	3000 kg	2,200 lb	1,000 kg	<b>158839</b> CTG-3032A-U \$8,601.50
13,200 lb	6,000 kg	4,400 lb	2,000 kg	<b>158841</b> CTG-6032A-U \$8,601.50
<b>4-Module Kit</b>				
880 lb	400 kg	220 lb	100 kg	<b>158833</b> CTG-442A-U \$11,274.50
1,700 lb	800 kg	440 lb	200 kg	<b>158835</b> CTG-842A-U \$11,274.50
2,500 lb	1200 kg	660 lb	300 kg	<b>158836</b> CTG-1242A-U \$11,274.50
4,400 lb	2000 kg	1,100 lb	500 kg	<b>158838</b> CTG-2042A-U \$11,274.50
8,800 lb	4000 kg	2,200 lb	1,000 kg	<b>158840</b> CTG-4042A-U \$11,274.50
17,600 lb	8000 kg	4,400 lb	2,000 kg	<b>158842</b> CTG-8042A-U \$11,274.50

Complete Kit Includes:  
Contego load cell, junction box, load cell extension cable

## Dimensions

Rated Capacity	A	B	C	D	E	F	G	H
in/mm								
Lateral cable	8.3 in (210 mm)	3.7 in (94 mm)	1.9 in (47 mm)	3.7 in (94 mm)	0.5 in (12 mm)	1.9 in (47 mm)	1.1 in (29 mm)	2.4 in (60 mm)

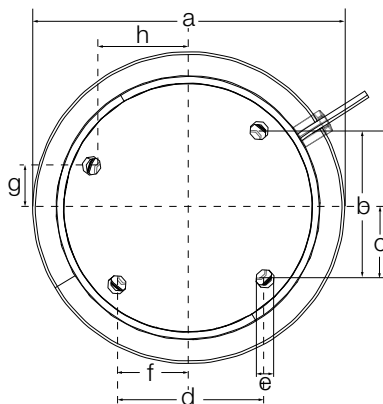

PRECISION INDUSTRIAL WEIGHING

www.ricelake.com | Phone: 800-472-6703

RICE LAKE