

Anti-Cavitation Main Valve

KO Anti-Cavitation Trim

Cla-Val's KO anti-cavitation trim represents a dramatic departure from the standard approaches usually employed to fight cavitation in valves that are required to undergo extreme pressure differentials and high velocity flow conditions.

Constructed of 316 Stainless Steel, the seat and disc guide feature dual interlocked sleeves containing cast radial slots that deflect internal flow to impinge upon itself, harmlessly dissipating potential noise and cavitation damage. The cast radial slots create a larger flow path than is possible with the standard drilled holes typically employed by other anti-cavitation valves currently available in the market place. The uniquely designed radial slots in the seat and disc guides also lessen the possibility of fouling if small particles are present in the water.

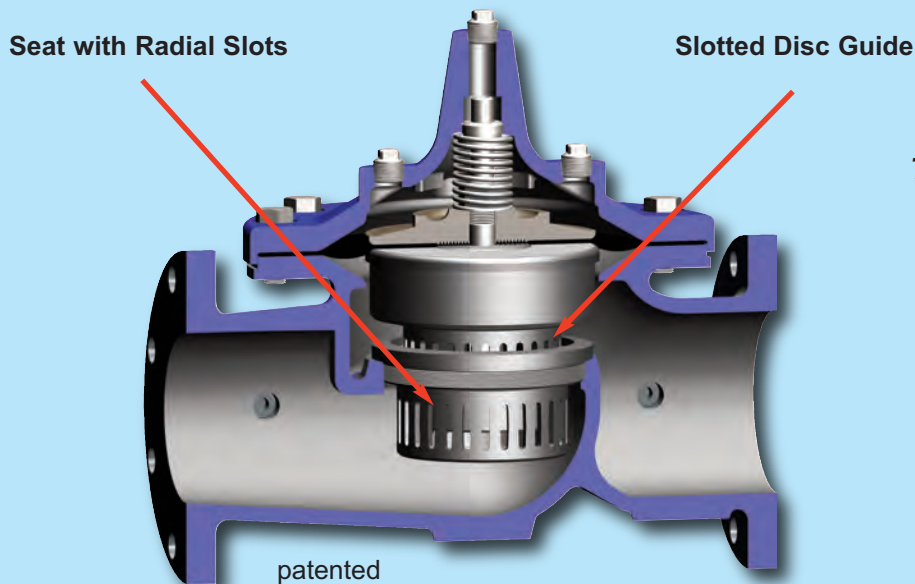

Typical Applications

- Pressure Reducing Valve Stations
- Tank Fill Valve Applications
- Noise Reduction in High-Rise Building Valve Stations
- Reservoir Level Control Valve Applications
- Booster Pump Bypass Stations
- Offshore Fire Pump Relief Valve Protection
- Applications with discharge to atmosphere
- Any application where valves are subjected to extreme pressure differentials or high velocity flow conditions

Cla-Val KO Anti-Cavitation Valve Principals of Operation

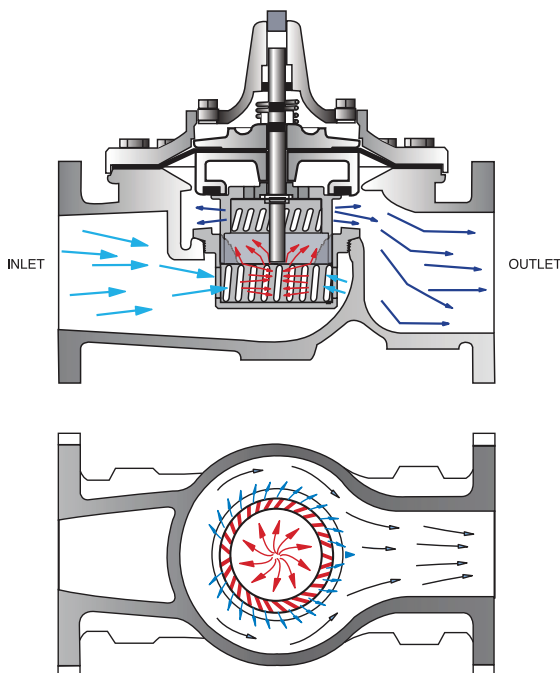

First Stage Pressure Reduction

- Flow enters through seat slots and reduces pressure

Second Stage Pressure Reduction

- Flow impinges upon itself within the seat and disc guide assembly to dissipate cavitation and further reduce pressure

Third Stage Pressure Reduction

- Flow exits through disc guide for final pressure reduction
- Diagonal disc guide slots direct flow away from surfaces



Cavitation Guide

The dark shaded portion of the chart illustrates the region where cavitation damage may occur. The lighter shaded portion is where significant cavitation noise and vibration may occur. Operating conditions inside the dark shaded area is permissible for infrequent periods of short duration. The guide is for modulating service valves. For on/off valves, consult factory.

The chart is based on cavitation index (sigma) values as defined by Utah State University Water Research Laboratory.

$$\sigma = \frac{(P_2 - P_v)}{(P_1 - P_2)} \quad \text{where}$$

σ = cavitation index, P_1 = inlet pressure (psi), P_2 = outlet pressure (psi), P_v = water vapor pressure (psia).

The dark shaded portion is below σ of 0.5 and the lighter shaded area is below σ of 0.8. The chart is to be used for typical valve operating conditions below 40% open at standard water temperature and elevation below 1000 feet.

More accurate cavitation conditions are determined from the **Cla-CAV** analysis program including static and dynamic inlet and outlet pressures, flow range, elevation, water temperature, and service conditions. If operation is inside the shaded areas, the **Cla-CAV** analysis can be used to determine whether added backpressure from an orifice plate, a second valve in series, or adding **KO** Anti-Cavitation trim (see 100-01KO data sheet). is necessary.

Cavitation Zones 100-01/100-20

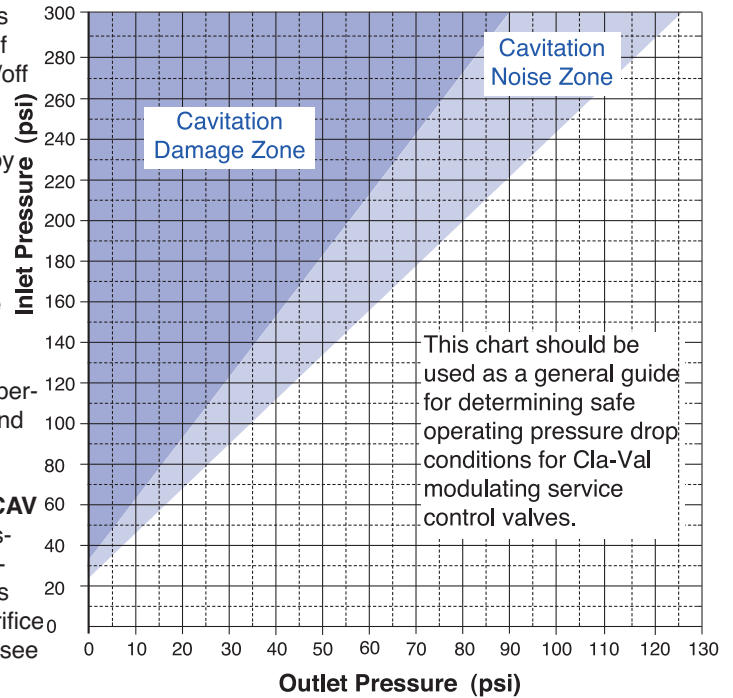

CLA-CAV Detailed Analysis Chart

Valve 1 100-01 100-20

Valve size: 6"

Maximum flow rate: 1000 gpm
 Minimum flow rate: 500 gpm
 Static inlet pressure: 120 psi
 Static outlet pressure: 25 psi
 Elevation above S.L.: 500 ft
 Water temperature: 60 deg F

Dynam. inlet pressure: 120.0 psi
 Dynam. outlet pressure: 25.0 psi

Back pressure orifice: Single
 Orifice backpressure: 61.9 psi
 Orifice discharge to: Downstream piping

Valve operation: Continuous (>50%)
 Avoid operation near (within 10%) cavitation damage level of 1.0.

Convert Units
 Dynamic Pressure
 Change Orifice
 Add Second Valve

For a more detailed cavitation analysis or if operation will be outside of the above chart, request a **Cla-CAV** computer analysis. **Cla-CAV** can evaluate what options best solve any potential cavitation problem. In the example shown, a 6 inch 100-01 modulating service valve requires an orifice plate downstream to prevent damaging cavitation. For wider flow range service, either an extra valve in series or the addition of **KO** Anti-Cavitation trim to the valve may be necessary (see 100-01KO data sheet). Consult factory for a free analysis for wide open or modulating service valves.

No damage
 Caution - near damage
 Damaging cavitation

Valve damage occurs <20 psi.

*Valve entrance velocity

Valve 1	Flow Rate GPM	Inlet (psi)	Outlet (psi)	% Open	Pipe Vel. (ft/s)	Cav Damage
	50	120.0	25.1	9.1	0.6	Yes
	250	120.0	27.3	19.9	2.8	Yes
	500	120.0	34.2	24.9	5.6	No
	750	120.0	45.8	30.7	8.3	No
	1000	120.0	61.9	37.2	11.1	No

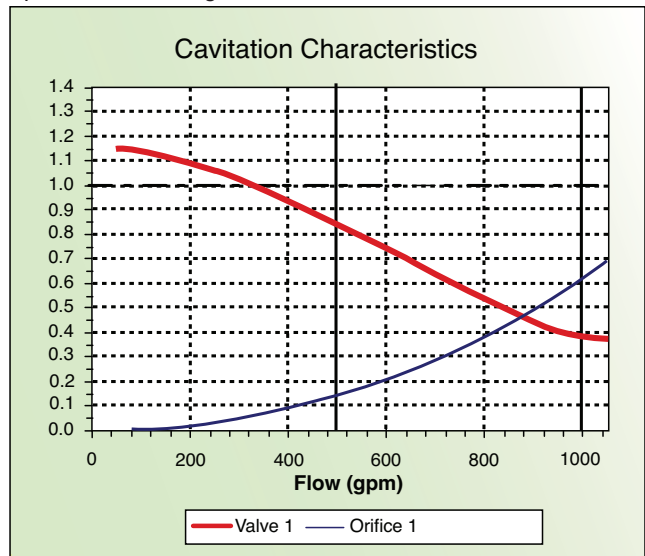

If the lines go above 1.0 there will be cavitation damage.



Anti-Cavitation Hytrol Valve

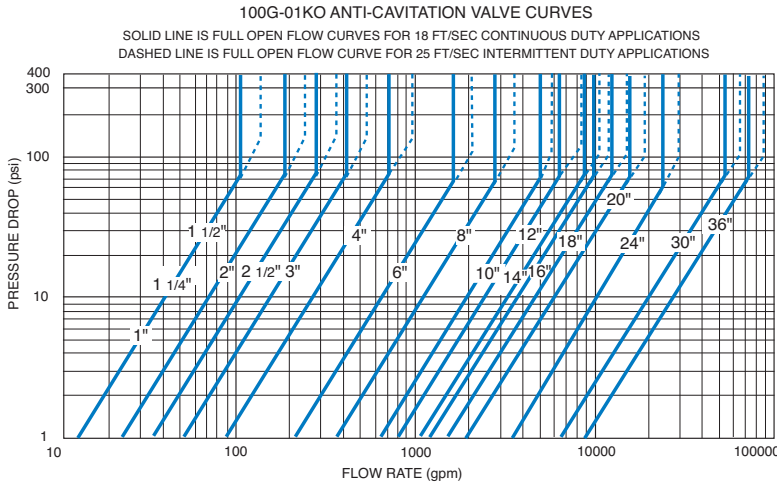

- Virtually Cavitation Free Operation
- Severe Service Design - High Pressure Differentials
- Reduced Noise and Vibration
- 316 Stainless Steel Disc Guide and Seat Standard
- Drip-Tight, Positive Sealing
- Service Without Removal From Line
- Retrofit to Standard Hytrol Valves

The Cla-Val Model 100-01KO Anti-Cavitation Hytrol Valve is designed for applications where there is a high potential for damage from cavitation. Specify this valve series for a wide variety of control valve applications having pressure differentials up to 300 psid or for relief valves having atmospheric discharge up to 150 psid.

Notes: On Operating Differential

1. For atmospheric discharge, the maximum inlet pressure cannot exceed 150 psi.
2. For pressure differentials greater than 300 psi the maximum flow velocity should not exceed 18 ft/sec.
3. Flow velocities greater than 25 ft/sec are not recommended.
4. Recommended minimum flow velocity is 1 ft/sec.
5. Consult factory for conditions exceeding these recommendations.

The 100-01KO Hytrol main valve provides optimum internal pressure control through a unique anti-cavitation trim design. Constructed of 316 Stainless Steel, the seat and disc guide trim components feature dual interlocked sleeves containing radial slots that deflect internal flow to impinge upon itself in the center of the flow path, harmlessly dissipating the potential cavitation damage. This unique design also lessens the possibility of fouling if large particles in the water are present due to the large flow path of the radial slots.

The 100-01KO Hytrol is the basic valve used in Cla-Val Automatic Control Valves for high differential applications requiring remote control, pressure regulation, solenoid operation, rate of flow control, or liquid level control.

The Anti-Cavitation Trim components can be retrofitted to existing valves if the application indicates an appropriate need. Please consult factory for details.

Functional Data

Valve Size		Inches	1 1/4	1 1/2	2	2 1/2	3	4	6	8	10	12	14	16	18	20	24	30	36
		mm.	32	40	50	65	80	100	150	200	250	300	350	400	450	500	600	750	900
C _v Factor	Globe Pattern	Gal./Min. (gpm.)	14	14	25	37	52	90	218	362	602	900	1100	1200	1550	1950	3900	4660	7100
		Litres/Sec. (l/s.)	3.4	3.4	6.0	8.9	12.5	21.6	52	87	144	216	264	288	360	469	938	1120	1706
	Angle Pattern	Gal./Min. (gpm.)	15	15	26	39	55	95	232	388	560	790	1075	1175	—	—	3775	—	—
		Litres/Sec. (l/s.)	3.6	3.6	6.2	9.4	13.2	22.8	56	93	134	190	258	282	—	—	906	—	—
Equivalent Length of Pipe	Globe Pattern	Feet (ft.)	196	196	237	277	416	572	858	1315	1483	2118	1937	3022	3537	4199	4532	6678	6567
		Meters (m.)	60	60	72	84	127	174	262	401	452	646	590	921	1078	1280	1381	2035	2002
	Angle Pattern	Feet (ft.)	171	171	219	250	372	514	757	1145	1714	2226	2021	3152	—	—	2583	—	—
		Meters (m.)	52	52	67	76	113	157	231	349	522	678	616	961	—	—	787	—	—
K Factor	Globe Pattern	30.6	30.6	26.1	24.3	29.3	29.0	25.5	27.7	24.9	27.7	22.8	31.4	30.2	29.5	15.4	30.1	25.1	
	Angle Pattern	26.7	26.7	24.1	21.8	26.2	26.0	22.5	24.1	28.7	29.1	23.8	32.8	—	—	16.4	—	—	
Liquid Displaced from Cover Chamber When Valve Opens	U.S. Gal.	0.2	0.2	.03	.04	.08	.17	.53	1.26	2.5	4.0	6.5	9.6	11	12	29	65	90	
	Litres	0.8	0.8	.12	.16	.30	.64	2.0	4.8	9.5	15.1	25.6	36.2	41.6	45.4	110	246	340	

For assistance in selecting appropriate valve options or valves manufactured with special design requirements, please contact our Regional Sales Office or Factory.

100-20KO — MODEL —

(Reduced Internal Port)



Anti-Cavitation Hytrol Valve

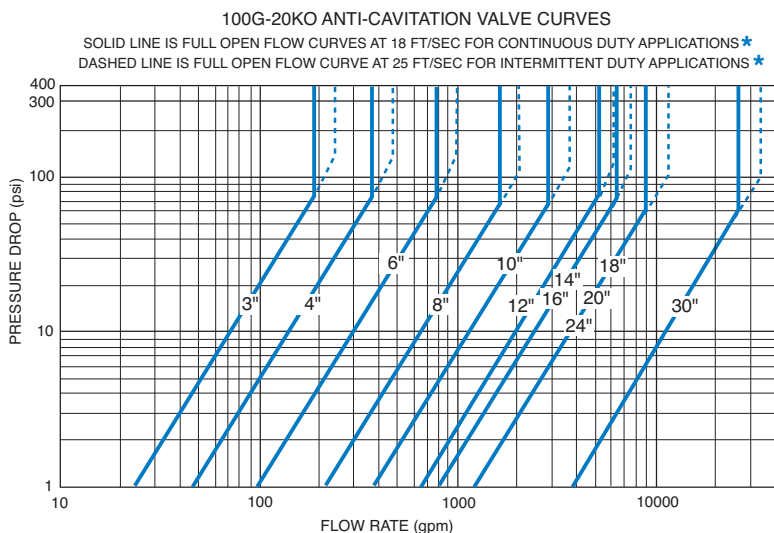

- Virtually Cavitation Free Operation
- Severe Service Design - High Pressure Differentials
- Reduced Noise and Vibration
- 316 Stainless Steel Disc Guide and Seat Standard
- Drip-Tight, Positive Sealing
- Serviced Without Removal From Line
- Retrofit to Standard Hytrol Valves

The Cla-Val Model 100-20KO Anti-Cavitation Hytrol Valve is designed for applications where there is a high potential for damage from cavitation. Specify this valve series for a wide variety of control valve applications having pressure differentials up to 350 psid or for relief valves having atmospheric discharge up to 150 psid.

Notes: On Operating Differential

*The 100-20KO Series is the reduced internal port size version of the 100-01KO Series.

1. For atmospheric discharge, the maximum inlet pressure cannot exceed 150 psi.
2. For pressure differentials greater than 300 psi the maximum flow velocity should not exceed 18 ft/sec.
3. Flow velocities greater than 25 ft/sec are not recommended.
4. Recommended minimum flow velocity is 1 ft/sec.
5. Consult factory for conditions exceeding these recommendations.

The 100-20KO Hytrol main valve provides optimum internal pressure control through a unique anti-cavitation trim design. Constructed of 316 Stainless Steel, the seat and disc guide trim components feature dual interlocked sleeves containing radial slots that deflect internal flow to impinge upon itself in the center of the flow path, harmlessly dissipating the potential cavitation damage. This unique design also lessens the possibility of fouling if large particles in the water are present due to the large flow path of the radial slots.

The 100-20KO Hytrol is the basic valve used in Cla-Val Automatic Control Valves for high differential applications requiring remote control, pressure regulation, solenoid operation, rate of flow control, or liquid level control.

The Anti-Cavitation Trim components can be retrofitted to existing valves if the application indicates an appropriate need. Please consult factory for details.

Functional Data

Model 100-20KO

Valve Size		Inches	3	4	6	8	10	12	14	16	18	20	24	30
		mm.	80	100	150	200	250	300	350	400	450	500	600	760
C _v Factor	Globe Pattern	Gal./Min. (gpm.)	25	46	98	240	409	660	910	925	1175	1225	1271	3900
		Litres/Sec. (l/s.)	6.0	11.0	23.5	57.7	98	159	219	222	342	348	358	708
	Angle Pattern	Gal./Min. (gpm.)	—	49	105	230	—	—	—	—	—	—	—	—
		Litres/Sec. (l/s.)	—	11.8	25.2	55	—	—	—	—	—	—	—	—
Equivalent Length of Pipe	Globe Pattern	Feet (ft.)	1435	2191	4244	3404	3884	8107	3359	6472	4185	6961	16582	14633
		Meters (m.)	437	668	1294	1038	1184	2471	1024	1973	1276	2122	5054	4460
	Angle Pattern	Feet (ft.)	—	1931	3697	3257	—	—	—	—	—	—	—	—
		Meters (m.)	—	589	1127	993	—	—	—	—	—	—	—	—
K Factor	Globe Pattern		101	111	126	72	65	42	40	67	36	53	106	68
	Angle Pattern		—	98	110	69	—	—	—	—	—	—	—	—
Liquid Displaced from Cover Chamber When Valve Opens	U.S. Gal.		.03	.08	.17	.53	1.26	2.5	4.0	4.0	9.6	9.6	9.6	29.0
	Litres		.12	.30	.64	2.0	4.8	9.5	15.1	15.1	36.2	36.2	36.2	110

For assistance in selecting appropriate valve options or valves manufactured with special design requirements, please contact our Regional Sales Office or Factory.