

The Heavy Duty Automatic Flatwork Separating System

CASCADE[®]

CHICAGO[®]



Untangle Your Laundry The Stress-Free Way

Separates wet, partially dry, or fully dry flatwork including sheets, large table linen, blankets, or knitted fitted sheets

Cascade is the next generation all-in-one free-standing labor saving system that can be located at the most convenient point in a finishing production line. Unlike any other linen separating method, Cascade is the comprehensive answer to the difficult task of untangling sheets, table linen, and blankets at a rate which keeps up with high speed automated spreader feeders. Cascade's multi-stage process eliminates the need for additional pre-separating devices such as shakers or cake breakers. Its compact footprint allows it to fit in virtually any laundry. It works ideally in conjunction with Chicago's premiere cornerless spreader/feeder models—Edge Tri-Maxx, Turbo King Edge Series, Ultra Maxx and more—to form the highest output, most efficient and effortless feeding system available. Cascade can also be used to improve the productivity of any other automated or manual feeding method.

Two Heads Are Better Than One

Chicago first introduced linen separation to the U.S. in 1998. Now Chicago introduces the next generation of linen separation systems for laundries that need to produce the highest continuous volume of separated linen to keep up with Chicago's fastest spreader feeders in the smallest footprint possible. Chicago's unique multi-stage process allows separating cycle times of up to 1600 pieces per hour. Chicago's exclusive intermediate holding area also provides the buffer supply of extra linen that a high speed finishing line requires to run without interruption while a fresh cart of tangled linen is moved into place.

Cascade is the premier linen separation system in the industry. This unique and rugged compact unit automatically separates and unloads carts of tangled flatwork and presents easily-handled separated items directly to feeding/ironing/folding operators. Linen can be separated from laundry carts of extracted, tumbled, or caked work or from an overhead or lateral conveyor delivery system.

Cascade should have a place in your laundry:

Saves Time

Eliminates the physically demanding stress, time, and drudgery of separating and shaking out tangled linen by hand.

Reduces Labor Costs

Substantially reduces the FTE hours required for manual preparation and feeding on sheet, table linen, or blanket finishing lines by eliminating costly bottlenecks caused by inefficient manual handling of linen.

Increases Operator Throughput

Improves and paces feeder productivity by supplying the highest possible volume of easy-to-handle prepared linen to feeders to make better use of the full capacity of automated ironing and folding equipment.

Coordinates Especially Well With Other Chicago Equipment

Optional electronic sensor can regulate flow of separated linen through a Cascade/LinenStream linen delivery system so operators are assured of proper supply of separated linen at all times.

Improves Employee Environment

Engineering advances in electronic control, pneumatics, and mechanics are used to address the ergonomic and musculoskeletal concerns relating to the physically demanding separation of masses of heavy wet linen by hand. Repetitive bending and twisting motions that often have a negative impact on back or arm muscles and soft tissue are eliminated because employees no longer have to manually lift, untangle, and pull apart large volumes of heavy wet linen.

Helps Employees to be More Productive

After a loaded cart is wheeled and locked into position, operator can be redirected to perform more productive tasks while automated separation is taking place—instead of remaining occupied untangling and shaking out linen. When the tangled linen cart is empty, an audio visual alert signals that a new cart can be loaded—all without stopping the separating process. Good employees are hard to find and tough to keep. Investing in an automated resource like Cascade to do the hardest work makes any human resource department's job easier.

Sequence of Separating Functions Why Cascade is the “Quicker Picker”

Untangling large batches of wet or tumble dried laundry is a tough job. Only Chicago has devised a way to do it at high speed within the framework of a compact machine. The secret is that Chicago does not try to do it in one step and does not require more than one piece of equipment to do it. Only Chicago separates linen in several sequential and coordinated steps. (Patent pending)

"Muscle Up Front...Finesse In the Back"

After a loaded laundry cart is locked into place, Cascade's powerful bulk separating clamp lowers into the cart, then grasps a manageable quantity of tangled linen and raises it to the level of a pivoting Cascade conveyor. As linen is draped across it, this conveyor begins to move and gradually drips partially separated linen into a separate holding area. Strategic linen deflection plates at the bottom of the holding bin direct items towards the final picking stage. Now that linen has been partially separated, independent dual fine picking heads can grasp and raise individual pieces of linen from the buffer supply. Timed air blasts then direct linen through the transfer rolls and onto the exit conveyor; discharged completely separated and easy-to-handle for operators feeding the ironing line. Linen can be discharged to a feeding table, cart, or optional Chicago LinenStream conveyor at either side of the machine – whatever works best to match the laundry's specific work flow and floorspace requirements.

Standard Features

- Compact design allows Cascade to be placed directly in front of feeder/ironer/folder
- Unit can also be located remotely for a tangled cart to “separated and ready” cart transfer
- Multi-stage separating and picking design with storage buffer allows reloading of fresh cart of tangled linen without interrupting separating operation
- Powerful transfer rolls work in conjunction with a high speed exit conveyor to assure optimum linen separation and easy operator handling
- Over 1600 picking cycles per hour (actual separation rate depends on piece size, severity of tangling, fabric content, moisture retention and load size)
- Visual and audible alert tells operator when a fresh cart of linen is needed or if separating process has been interrupted
- Electronic output available to signal auxiliary equipment such as monorail/sling or conveyor system to deliver additional linen when needed
- All components readily accessible to maintenance personnel
- Rugged construction from the oldest name in flatwork finishing
- Discharge side is field reversible at the flick of a switch
- Internal flow sensors keep buffer trough at proper linen supply level
- Designed and fabricated in Chicago with immediate parts availability and service support.

Flexible Floorplan

Linen can be loaded from the front, left, or right of unit. Separated linen can be discharged to the left or right of unit at the touch of a switch.

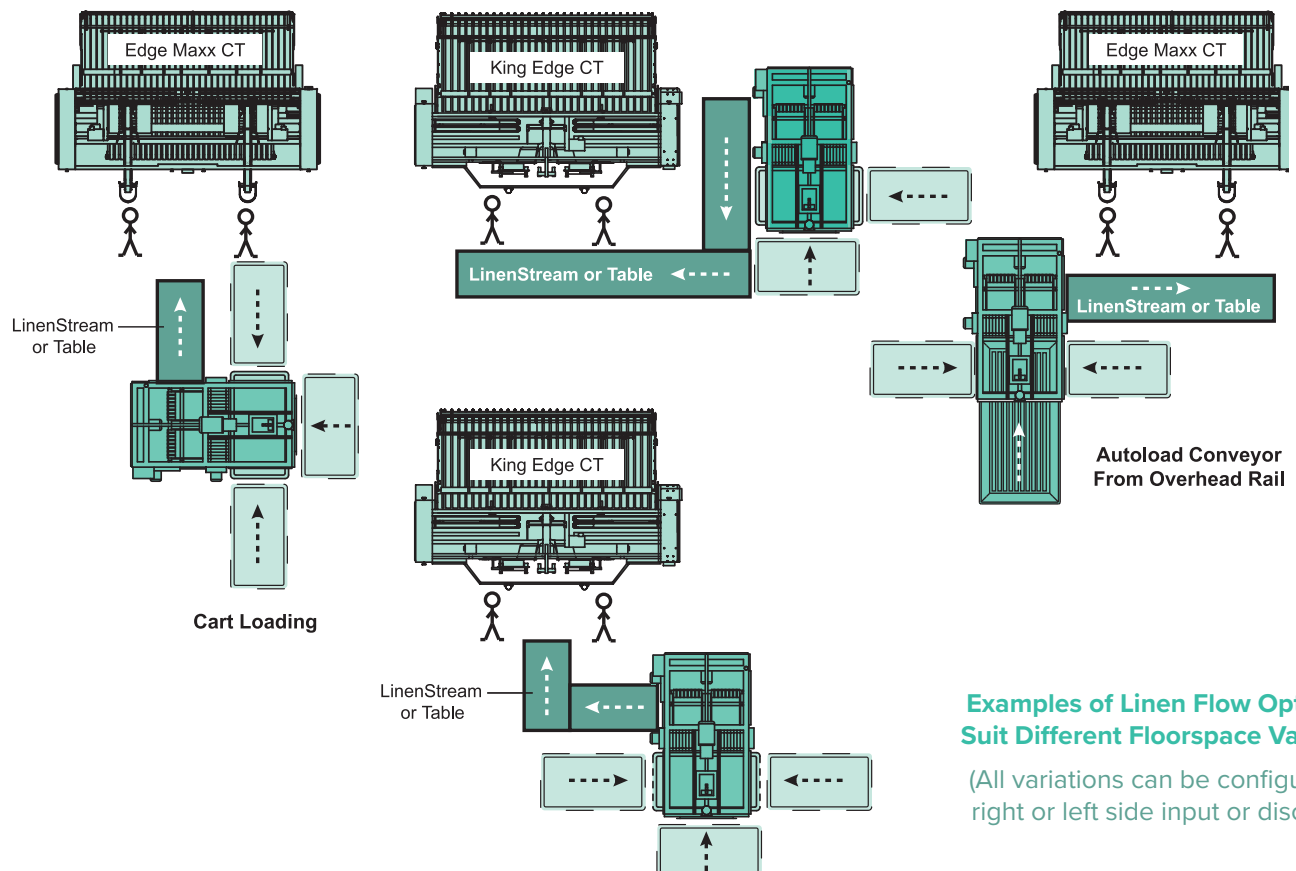

Examples of Linen Flow Options to Suit Different Floorspace Variations

(All variations can be configured for right or left side input or discharge)

Remote Separation

If there is no room directly in front of the finishing line, laundries can use Cascade in a “cart to cart” system where linen is processed from a tangled cart into a separated cart away from the finishing line. Separated carts are then wheeled to the front of the finishing line as needed. In this way, an added buffer supply of separated linen can also be maintained. Cascade’s flexibility is the key to meeting the needs of any existing or new laundry layout.

Modular Design

Separated linen can be discharged from the exit conveyor to a Chicago LinenStream intelligent conveyor system or locally supplied table, cart, or distribution conveyor. Cascade’s flexible and compact separating platform can easily adapt to fit any laundry, regardless of size. Streamlined linen flow, swift investment payback, and the improvement of working conditions through the elimination of one of the toughest jobs in any laundry combine to make Cascade a valuable performer with outstanding ROI in any high production facility.

Optional LinenStream Delivery Conveyor

The optional LinenStream laundry conveyor is Chicago’s intelligent system for the distribution, advancing and flow control of separated linen from the Cascade to the optimal position for efficient operator feeding. It is available in 6’ [1830mm], 8’ [2440mm], 10’ [3050mm] or 12’ [3650mm] lengths, and custom configurations to suit any efficient laundry layout.



Cascade

Dimensions and Utilities

NOTE:

1. Specifications subject to change without notice. Consult factory for certified construction floorplan.
2. Millimeter dimensions are in [].
3. All dimensions are +/- 1/2".
4. Utility connections are located at rear.

CONNECTION(S)	DIA.	HEIGHT
A Air Connection	1/2"	86" [2184]
E Electrical Connection	--	83" [2102]

Top View

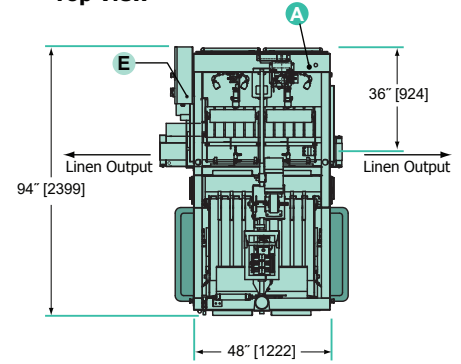

Side View

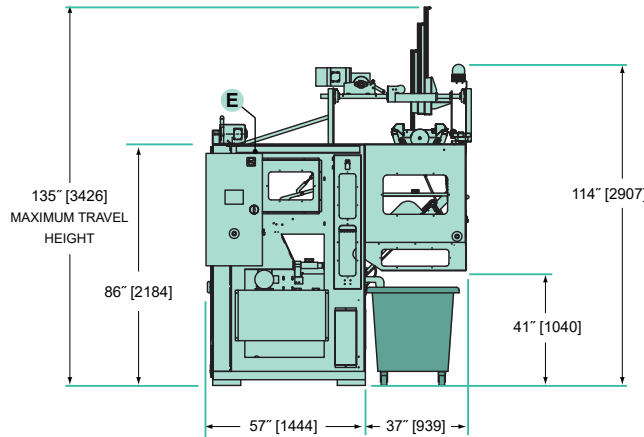

Front View

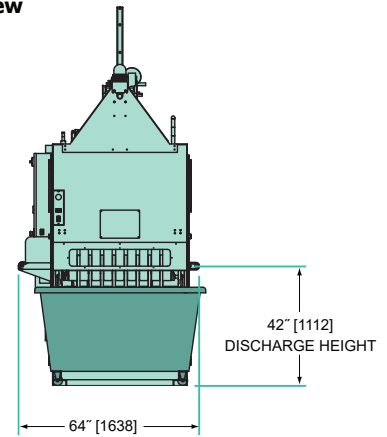

Versatile design allows use with a wide variety of carts or conveyors with a choice of input and output sides

Utility Requirements

Cascade will accommodate most wheeled laundry carts as shown below.

	Minimum	Maximum
Length	47" [1200mm]	60" [1520mm]*
Width	30" [762mm]	40" [1020mm]
Height	27" [686mm]	36" [915mm]

* cart may require manual repositioning to ensure maximum productivity

Consult factory for use with other input cart sizes, conveyor, or monorail sling.

Visit Chicago's website www.chidry.com for easy access to the latest floorplans, technical specifications, etc.

A Complete Range of Separating, Feeding, Ironing, Folding, and Sorting Options

Because Chicago specializes only in flatwork finishing equipment, it can offer the world's widest range of high production separating, feeding, ironing, folding and sorting equipment. Complete flatwork finishing systems range from automated multi-roll systems producing over 2000 pounds per hour, to compact ironers for small on-premise laundries.

Chicago's performance record is unmatched in thousands of installations in commercial, hospitality, health care, textile rental, institutional and on-premise

laundries all over the world. An experienced Chicago professional will be pleased to make an objective equipment recommendation based on your production, space, utility and budget requirements. Contact your local Chicago distributor or the factory sales assistance office for a no-obligation analysis of your needs.

Chicago's Customer Service department offers full technical and service support by telephone and on our website. We also offer overnight service for quick parts availability. Visit our website, www.chidry.com, to learn more about our complete line of flatwork finishing

CHICAGO[®]



CHICAGO DRYER COMPANY
2200 North Pulaski Road
Chicago, Illinois 60639-3737 USA

Phone • 773.235.4430
Fax • 773.235.4439
Web • www.chidry.com
Email • chicago@chidry.com