

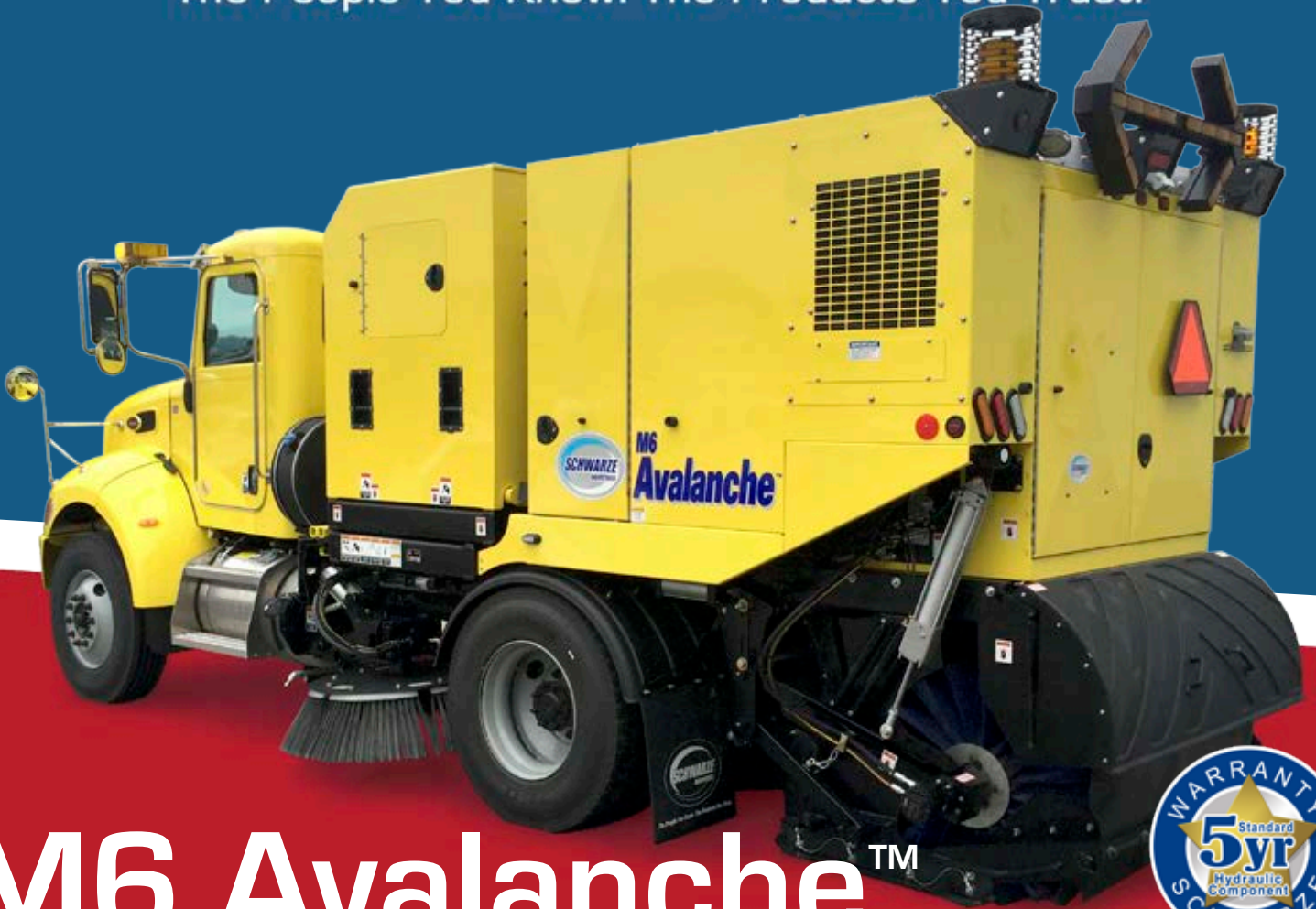

The People You Know. The Products You Trust.



M6 Avalanche™

5 Cubic Yard Mechanical Broom Street Sweeper



*Sweeper shown with optional equipment

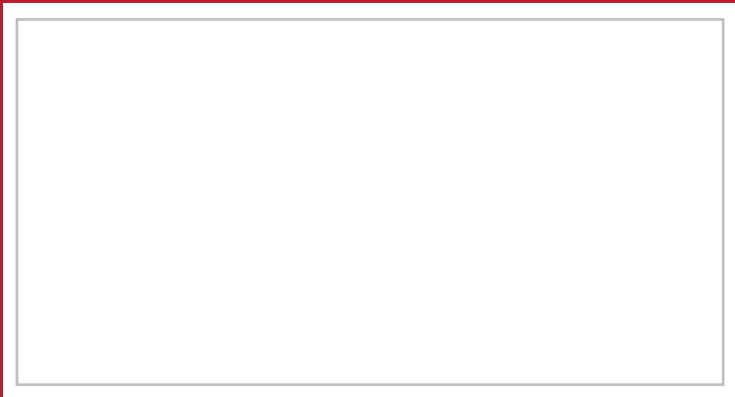

- Easy Change Conveyor System
- Central Located Control Components
- Illuminated Hopper Interior
- 5 Micron Water Filter System

Quality	Performance	Public Safety	Value	Customer Support

800.879.7933

www.schwarze.com

Up to 138" Dump Height

M6 Avalanche™

5 Cubic Yard Mechanical Broom Street Sweeper



Brass & Galvanized Steel Spray Bars

*Optional Equipment Shown, Blue Frame Special Order

Variable high dump with up to 52 degree dump angle.

Easy to use backlit switches with text and icon labels.



MUST HAVE OPTIONS

CONVEYER

Choose between a belt or squeegee conveyer.

GREATER VISION

Add up to two additional cameras (3 total) to the backup camera system.

PRESSURE WASHING

Add a pressure washer with hose reel for easy cleanup and pressure washing.

GET NOTICED

With your choice of arrowboard, extra flood lights and extensice safety lighting.

49" Diameter Side Broom(s) with Gutter Broom Extension Override.

Easy access to sweeping and control components.



Available With
CUMMINS
Tier 4
Sweeper Engine

VALUE

We are dedicated to satisfying our customers by providing the most advanced training for their specific needs. Our training programs are designed to help operators of all skill levels learn the best operating practices for their Schwarze equipment.



PERFORMANCE

There is a lot riding on creating solutions that are suited to the particular needs of different industry applications. Innovation often involves high technology, but doesn't always have to be. Some of our best ideas have been simple, based on a clear and deep understanding of our customers' working lives.



QUALITY

In a Schwarze product, end user concerns like fuel efficiency, serviceability, durability, purchase cost, service cost, etc. are all taken into account. We also consider the needs and strive for ease of use and application optimization. It should be obvious, because when it comes to cost of ownership, quality pays.



PUBLIC SAFETY

No other name speaks safety louder than Schwarze. Protecting operators, those around them, and minimizing our environmental impact are traditional values that continue to shape our product design philosophy.



CUSTOMER SUPPORT

Being a Schwarze customer means having a complete set of services at your fingertips. Schwarze can offer you a long-term relationship, protect your revenue and provide a full range of customer solutions, delivered by passionate people. At Schwarze, we don't see effective service and support just as an added value to your purchase, but as an integral part of it.

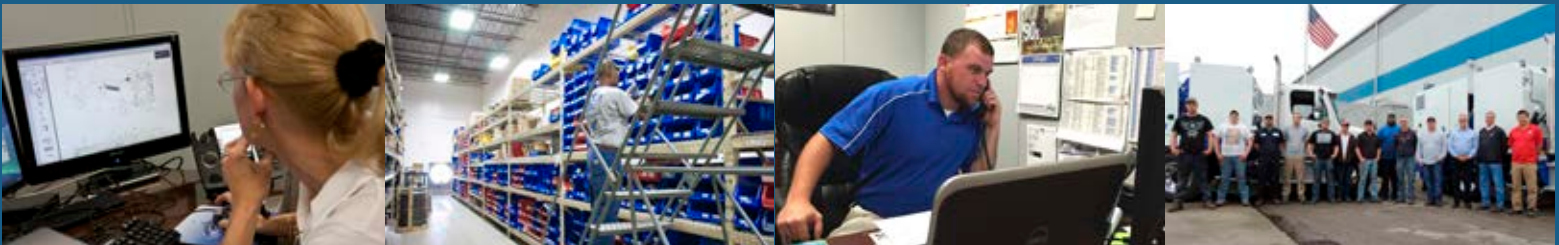

Also Available from Schwarze Industries, Inc:



M6 Avalanche

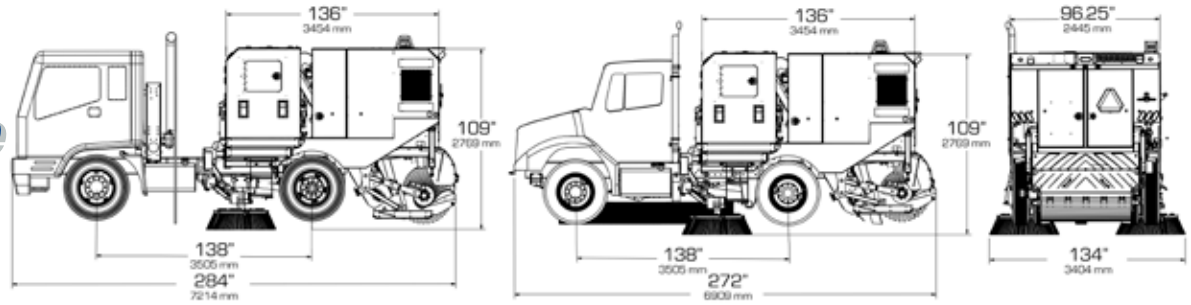

*TYPICAL MEASUREMENTS SHOWN, EXACT DIMENSIONS DEPENDING ON OPTIONS AND TRUCK MANUFACTURER

CONVEYER

Bearings	Self-aligning, triple-sealed and shielded
Conveyer floor	Bolt-on; replaceable
Speed	Forward and reverse, in-cab variable speed standard, independent from engine rpm
Adjustment	Threaded rack
Drive	Direct drive hydraulic; forward and reverse
Hopper connection	Positive seal to eliminate debris spillage
Suspension	Air cylinders with in-cab adjustment for lower conveyer lift
Conveyer jam warning	Console-mounted, light and alarm

CONVEYER / SQUEEGEE

Conveyer	Squeegee with replaceable flights
Conveyer chain	Precision, heavy duty, constant-radius roller chain
Flexibility	Flexes for large object passage
Cleaning	Built-in flushing system with high volume fan jet nozzles

CONVEYER / BELT

Conveyer	Heavy duty multi-ply belt with full width cleats
Cleaning	Built-in flushing system with high volume fan jet nozzles and lower roller flush

WATER SYSTEM

Capacity of tank	<i>SE conventional:</i> 350 gal (1325 L) <i>SE cabover:</i> 350 gal to 700 gal (1325 L to 2650 L) <i>TE conventional:</i> 200 gal (1230 L) <i>TE cabover:</i> 350 gal to 500 gal (1325 L to 2555 L)
Construction	Polyethylene
Filler	4 in (102 mm) air gap fill; tubular protected fill receptacle
Fill	Hose 25 ft with 2.5 in nst hydrant coupling (7620 mm x 63.5 mm)
Mounting	Bolt-on, removable
Pump	Electric diaphragm pump, 5.88 gpm (22.3 Lpm) at 50 psi (3.5 bar)
Spray bars	In-cab, independent control; 7 nozzles located across front bumper, 4 nozzles at each gutter broom and 5 nozzles across the main broom
Spray nozzles	All brass 80 degree fan pattern with 100 mesh tip strainer
Filter	200 mesh screen primary with 5 micron high capacity secondary filter

FUEL SYSTEM

Fuel tank	<i>Diesel,</i> 50 gallons (189.25 L) <i>CNG,</i> 50 DGE (Diesel Gal. Equivalent) at 3600 psi
-----------	---

HYDRAULIC SYSTEM

Pump	Variable displacement load sense piston pump
Reservoir	35 gal (133 L) mounted above pump
Oil cooler	120 000 btu twin electric fans
Valves	Electro-mechanical; 12 V dc with lighted din connectors
Protection	Pressure relief
Controls	In-cab; all electric
Filtration	100-mesh suction, 10-micron return, 5-micron breather

ELECTRICAL SYSTEM

Voltage	12 V
Alternator	160 amp

SWEeper ENGINE (TWIN ENGINE ONLY)

Engine	Yanmar Tier 4 Final or Deutz Tier 4i
Alternator	55 amp
Displacement	202 cu in (3.3 L)
Horsepower	68 hp @ 2500 rpm
Torque	184 ft lb (250 Nm) @ 1600 rpm

GUTTER BROOMS

Location	Behind cab
Diameter	49 in (1245 mm)
Type	5 segment wire filled plastic recyclable head in-cab variable speed standard, independent from engine rpm
Speed	Free-floating with air suspension and air extension
Suspension	Full hydraulic
Drive	Manual tilt; in-cab remote hydraulic tilt (optional)
Adjustments	26 in (660 mm) wire
Bristles	Raises and lowers automatically with main broom
Center deflector	

MAIN BROOM

Diameter	36 in (914 mm)
Length	58 in (1473 mm)
Bristles	Replaceable solid core, poly wafer, poly wafer/ steel combo or strip broom
Lift control	In-cab pneumatic lift with positive lock
Drive	Direct drive hydraulic motor
Mounting	Full floating
Speed	Forward and reverse, in-cab variable speed Standard, Independent from engine rpm
Bearings	Self-aligning
Dirt shoes	Trailing arm design with 2 in (51 mm) wide Tungsten carbide shoe with elastomeric flex link
Suspension	Air suspension with in-cab adjustment and display

DEBRIS HOPPER

Volumetric capacity	5.0 cu yds (3.82 cu m)
Construction	3/16 in floor, 10 gauge sides/ roof, temper pass/pickled in oil carbon steel optional stainless steel
Gross lift capacity	14 000 lbs (6350 kg)
Dumping	Scissor-lift with hopper tilt
Dump height	(Variable) 16 in (406 mm) to 138 in (3505 mm)
Inspection	Side door with ladder access, front view window with double skylight and led illumination

GENERAL

Wheelbase	<i>SE and TE-</i> 139 in (3532 mm) <i>Cabover-</i> 132 in (3353 mm)
Length	<i>SE and TE-</i> 273 in (6934 mm) <i>Cabover-</i> 269 in (6833mm)
Travel width	96 in (2438 mm)
Sweeping width	134 in (3404 mm) (brooms extended)
Overall height	113 in (2870 mm)
GVWR	33 000 lbs (14 969 kgs)

PAINT

One coat of sealer/primer and two coats of DuPont Imron Elite polyurethane white color

Note: Specifications are subject to change without notice.

Affiliates:



© 2018 Schwarze Industries
1055 Jordan Road
Huntsville, AL 35811
800.879.7933
An Alamo-Group Company

