

NEW



BACKHOE LOADER | 3CX COMPACT

Gross power: 74hp (55kW) | Maximum dig depth: 14ft 2" | Weight: 13,382lbs



Introducing the **3CX Compact** the ultimate tool carrier..

JCB pioneered the backhoe loader in 1953 introducing many innovative features to the market. And in a rapidly changing world, JCB continues to evolve to meet customer demands. Our latest innovation, the 3CX compact is the answer to those changing needs. Find out why it is the ultimate tool carrier.





MORE COMPACT.

SPACE IS BECOMING A PREMIUM. THAT'S WHY THE NEW 3CX COMPACT HAS BEEN DESIGNED TO GIVE YOU BIG PERFORMANCE IN A SMALL AREA. THIS MAKES IT PERFECT FOR URBAN WORKING AND RESTRICTED CONSTRUCTION SITES.

1 Ideal for the tightest urban applications with minimal disruption, due to the ability to road between sites. These jobs are often completed by hand.

2 At only 6' 2" wide the 3CX Compact is almost 18 inches narrower than a standard backhoe (attachment dependant). And a 9ft travel height allows the 3CX Compact to access much tighter spaces.

3 The low height unlocks a whole new range of previously inaccessible work sites, such as low level buildings and basements.

4 Its narrow width makes the 3CX Compact ideal for entering cemeteries, parks and small construction sites with restricted access.



**35% smaller than
a standard backhoe.**



MORE MANEUVERABLE.

THE NEW 3CX COMPACT IS THE ULTIMATE IN MANEUVERABILITY. ITS TIGHT TURNING CIRCLE AND SWITCHABLE STEERING MODES ALLOW IT TO WORK IN A TWO LANE HIGHWAY WITH MINIMUM DISRUPTION AND MAXIMUM PRODUCTIVITY.

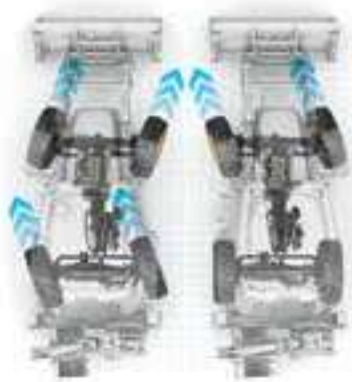

1 Four-wheel steer Two-wheel steer

1 Switchable 2WS/4WS allows the operator to change between roading mode to site with ease.

2 An impressive 19ft turning circle (with applied brakes) allows the machine to turn a full 180 degrees in a two lane highway.

3 A three speed 25 mph hydrostatic transmission makes the 3CX Compact an incredibly independent machine with a large working radius for optimum productivity without the reliance on other equipment to transport.

4 The 3CX Compact is powered by a high torque 74hp JCB by Kohler engine that requires no after treatment keeping servicing costs and downtime to a minimum.



16% tighter turning radius
than a standard backhoe.



MORE VERSATILE.

THE 3CX COMPACT IS NOT ONLY DESIGNED FOR THE VAST RANGE OF TOOL CARRIER ATTACHMENTS. IT ALSO HAS THE ABILITY TO PICK UP A WIDE RANGE OF ATTACHMENTS. HAMMER PIPEWORK AND A HANDHELD TOOL CIRCUIT PROVIDE EVEN GREATER VERSATILITY.



The **versatile** one machine solution.



EASIER TO OPERATE.

A SPACIOUS CAB WITH PILOT CONTROLS PROVIDES OPTIMUM EASE OF USE AND CONTROLLABILITY. THIS ALSO HELPS TO IMPROVE THE OPERATOR'S SEATING POSITION, WHICH IN TURN MAKES IT A LOT MORE COMFORTABLE.

1 Three speed controls allow the correct speed to be selected simply at the touch of a button



2 Excavator style controls are fitted as standard providing ease of use and controllability.

3 A fully adjustable suspension seat provides fatigue free all-day operation.



4 A front dash mounted display provides all the information when roading and loading.

5 A 12V auxiliary circuit for powering of useful accessories, such as cell phones.

6 An SAE/ISO control pattern switch is fitted as standard for ultimate customization.



Excavator style **pilot controls**
come standard.



GREAT RETURN ON INVESTMENT.

JCB'S LEGENDARY BUILD QUALITY AND GLOBAL BRAND HELP KEEP CUSTOMER DEMAND AND MACHINE RESIDUALS HIGH. AND THE BENEFITS OF OWNING A NEW 3CX COMPACT DON'T STOP THERE.



1 We've used only proven reliable components on the 3CX Compact to maximize uptime and ensure that your machine spends as much time as possible earning you money.



A 25 mph road speed eliminates the need to rent or purchase a trailer for transport.

2 A high specification at a competitive price gives you maximum value for money. A full range of attachments increase versatility and allow for greater rental return.



3 LiveLink is standard enabling you to monitor utilization of your investment, fuel consumption and machine location.



4 JCB backhoe loaders have become a global currency, due to their enviable reputation for both quality and high residual values.



Designed for great
versatility and **value.**



PERFECT FOR ROAD RESURFACING.

WHEN IT COMES TO ROAD RESURFACING, VERSATILITY AND SPEED WITH MINIMAL DISRUPTION ARE PARAMOUNT. THE NEW 3CX COMPACT CAN TRAVEL QUICKLY AROUND SITE. IT CAN TURN AND WORK IN A TWO LANE HIGHWAY AND EVEN DRIVE OVER FRESH ASPHALT. IT IS THE PERFECT MACHINE FOR ROAD RESURFACING.

1 The 3CX Compact can drive over fresh asphalt unlike skid steer loaders and excavators, due to its 13,382 lb weight, 4-wheel-steer and rubber tires.

25 mph travel speed and a 19ft turning circle make the machine quick and nimble around busy job sites.

2 At only 13,382 lb and 9ft tall this machine can be easily transported along with all equipment needed to complete the job.

3 Excellent visibility due to a commanding driving position and large glass window area.

4 Designed for the job. The The tool carrier has been the product of choice for this application for the last 20 years. Street pads is just one example of a customer specified feature.





6-in-1 Loader Bucket

Six applications with one attachment (dig, doze, grab, grade, load and backfill). Bolt on hardened toe plate fitted for increased attachment life.

Breaker

Fitted with a dipper mounted HM166Q breaker, ideal for breaking the top layer of asphalt, prior to planing when road resurfacing.

Handheld tool circuit

The 29' 6" hose reel provides power to a wide variety of hydraulic tools in a large working radius, and its auto retract system makes it easy to put away after use.

LED Work lights

2 front and 4 rear high powered LED lights as standard give you daylight working conditions at night. Optional 10 LED pack also available.

Street pads

Stabilizer street pads reduce damage to road surfaces. Shovel street pads are also available for increased protection.

More versatile than ever before

An Mk2 Loader Quick coupler is standard to maximize the machine's versatility.

IDEAL FOR ROAD REPAIRS.

THE 3CX COMPACT IS AVAILABLE WITH THE PERFECT SPECIFICATION TO BE A SINGLE-MACHINE SOLUTION FOR PERMANENT POTHOLE REPAIR PREPARATION, COLLAPSED DRAINS, CURBS AND MORE. WITH A POWERFUL PATCH PLANNER, SWEEPER COLLECTOR AND TOW HOOK TO BRING TO SITE USEFUL HANDHELD TOOLS, IT REALLY IS THE ULTIMATE IN ROAD REPAIRS.

1 A handheld tool circuit allows use of power tools such as disc cutters or breakers. The tools can even be used at the same time as the attachments on the machine.



2 The ability to do perfect preparation for a permanent pothole repair by planing, cutting and sweeping up.



3 A compact size allows it to work in confined areas that are inaccessible for standard size backhoes.



4 19ft turning circle means it can work in a two lane highway allowing a road to be kept open.



5 The versatility to do the work of multiple machines like drainage, forkwork, moving curbstones and carrying material such as hot tar.





Sweeper collector

The sweeper collector ensures thorough surface preparation. Its offset design allows work to be carried out in a two lane highway, eliminating disruption to traffic.

Patch planer

The powerful high speed drum cuts clean vertical sides to any planed area. This allows consistent, clean compaction of new tarmac into the prepared area.

Handheld tool circuit

The 29' 6" hose reel provides power to a wide variety of hydraulic tools in a large working radius, and its auto retract system makes it easy to put away after use.

Handheld breaker

A HM25LV breaker is included. This low vibration model provides an excellent power to weight ratio and comes with an external holster.

Extending dipper

10' extending dipper reduces the need to reposition the machine, saving valuable time.

Additional features and attachments

Switchable SAE/ISO controls; Stabilizer street pads; LED light kit.

FITS THE BILL FOR UTILITIES.

THE 3CX COMPACT IS PERFECTLY TAILORED FOR THE UTILITIES SECTOR. IT CAN TRAVEL QUICKLY TO SITE, MANEUVER IN TIGHT SPACES AND WORK WITH MULTIPLE ATTACHMENTS FOR TRENCHING WORK AND SITE PREPARATION. ALL THIS WITH MINIMUM DISRUPTION AND DAMAGE.

1 25 mph road speed for fast deployment to deal with emergencies such as burst water pipes, gas leaks and telecom repairs.



2 Handheld tool circuit provides additional functionality to use water pumps for flooded trenches, hand breakers and much more.



3 Under 6' 2" width means you only have to close off a two lane highway.



4 Under 19ft turning circle gives it the maneuverability to work in confined spaces.



5 The one machine solution for cutting asphalt, digging ground, lifting pipes, carrying and unloading equipment and materials, backfilling, compacting trenches and sweeping up afterwards.





LED kit with dipper mounted work light

2 front and 4 rear high powered LED lights give you daylight working conditions at night. The dipper mounted work light gives direct light to the working area.

HM 266Q breaker

High blow rate breaker with built in sound suppression. A solid body design provides maximum strength and power for excellent breaking performance.

Handheld tool circuit

The 29' 6" hose reel provides power to a wide variety of hydraulic tools in a large working radius, and its auto retract system makes it easy to put away after use.

Extending dipper

10' extending dipper increases lifting radius, reducing the need to reposition the machine.

Street pads

Street pads on the stabilizers and on the 6 in 1 shovel provide maximum surface protection.

Additional features and attachments

Standard SAE/ISO changeover. Handheld breaker; 12" and 24" buckets with toeplate; Grading bucket; Submersible pump are available as options.

YOUR PAL FOR MUNICIPALITIES.

WITH LOCAL AUTHORITIES AND MUNICIPALITIES HAVING SUCH VARIED RESPONSIBILITIES, ITS VERSATILITY MAKES THE 3CX COMPACT THE PERFECT MACHINE. ITS SIZE LETS IT GET TO JOBS WHERE A BIGGER MACHINE JUST COULDN'T GO. ITS ABILITY TO USE A HUGE RANGE OF ATTACHMENTS INCLUDING HANDHELD TOOLS, MAKES IT A GREAT VALUE, RELIABLE WORK HORSE.

1 One machine solution that offers great versatility and value for money. It can perform multiple tasks and do the work of both a compact wheeled loader and mini excavator. From park maintenance in the summer to loading salt trucks and snow clearing in the winter, the 3CX Compact really is a machine for all seasons.



2 Its ability to quickly travel to and from sites as well as around large areas such as parks means one machine can be very productive.



3 A handheld tool circuit further increases the ability for one machine to tackle any job, such as pumping water and using augers to plant trees.



4 The 3CX Compact is lightweight and narrow with excellent maneuverability. When combined with turf tires and the ability to dig to 12 ft, this machine is ideal for grave digging.



5 Under 6' 2" machine width gives it the ability to work in confined areas which are inaccessible to larger machines (attachment dependent).





6-in-1 Loader Bucket

Six applications with one attachment (dig, doze, grab, grade, load and backfill).

Front and rear quickhitch

Easily switch between attachments for complete versatility on any job. Both hitches allow for effortless attachment changes.

10 foot extending dipper

10' extending dipper for less repositioning of the machine and in turn higher efficiency. An optional 12' dipper is also available.

Handheld tool circuit

The 29' 6" hose reel provides power to a wide variety of hydraulic tools in a large working radius, and its auto retract system makes it easy to put away after use.

Loader Quick Coupler

This versatile tool is available and allows customers to pick up a wide variety of attachments to increase their productivity on the 3CX Compact tool carrier.

Additional features and attachments

Switchable SAE/ISO pattern; LED light kit; 24" bucket; Stabilizer street pads.

THE WORKS FOR SITE DEVELOPMENT.

WHEN IT COMES TO SITE DEVELOPMENT THE 3CX COMPACT WORKS PERFECTLY. DESIGNED TO WORK EFFORTLESSLY AND SAFELY IN TIGHT MODERN HOUSING DEVELOPMENTS WITH THE ABILITY TO UTILIZE A WHOLE HOST OF USEFUL ATTACHMENTS, IT REALLY IS PERFECT FROM THE GROUND UP.

1 Avoids the need for multiple machines on site such as dumpers, compact wheeled loaders, mini excavators, forklifts and motorized sweepers.



2 Capable of multiple jobs such as fork work, moving material, digging footings, lifting mortar tubs, site stripping and sweeping to keep the site clean at the end of the day.



3 Compact size enables the machine to work between houses and access back gardens for landscaping.

Under 19ft turning circle gives it the maneuverability to work in smaller housing developments.

4 A 25mph road speed allows it to travel to and around site quickly increasing productivity.





Dedicated forks

Industrial forks are perfect for loading, stocking and rehandling. Built-in load guard offers greater operator safety.

6-in-1 Loader bucket

Six applications with one attachment (dig, doze, grab, grade, load and backfill). Shovel ram guards provide additional protection from debris.

Handheld tool circuit

The 29' 6" hose reel provides power to a wide variety of hydraulic tools in a large working radius, and its auto retract system makes it easy to put away after use.

LSD axles

The optional limited slip differentials ensure maximum productivity in all ground conditions by providing additional tractive effort.

Submersible pump

The self-priming, high powered 185 gpm submersible pump that can be used in conjunction with the machine operation.

Additional features and attachments

Stabilizer street pads; Lifting kit; 24" bucket; Switchable SAE/ISO pattern; LED light kit.

LIVELINK, WORK SMARTER.

JCB LIVELINK USES THE LATEST SATELLITE TECHNOLOGY TO HELP YOU MONITOR AND MANAGE YOUR MACHINE REMOTELY ANYWHERE IN THE WORLD VIA WEB, EMAIL OR MOBILE. SO WHETHER YOU'RE AN OWNER OPERATOR OR RUN A FLEET, LIVELINK CAN RADICALLY IMPROVE THE EFFICIENCY AND SECURITY OF YOUR MACHINES.

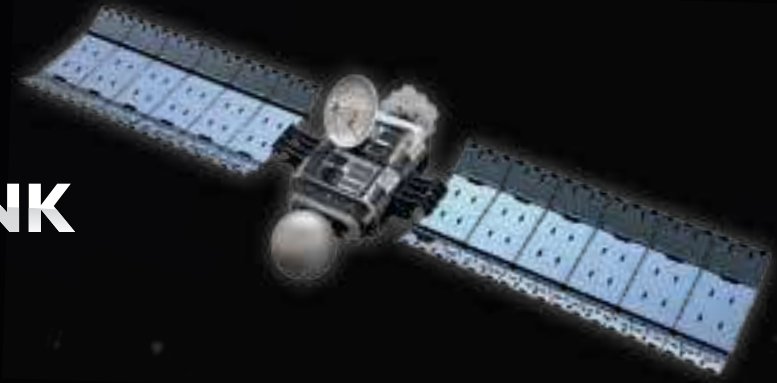

Machine efficiency

1 By providing information like idle time monitoring and fuel consumption, JCB LiveLink saves you money and improves productivity.

Machine reliability

2 Accurate hours monitoring and service alerts improve maintenance planning and help rental companies with accurate charging. Technical alerts and maintenance history records help you manage your machines.

Machine monitoring

3 Keep track of what your machine's been doing throughout the day with regular performance reports accessed via the LiveLink website.

Machine Security

4 LiveLink's real time geo-fencing alerts tell you when machines move out of predetermined zones. Curfew alerts inform you of unauthorized usage. JCB have a history of working with the police to recover stolen machines and tackle fuel theft.



1



2

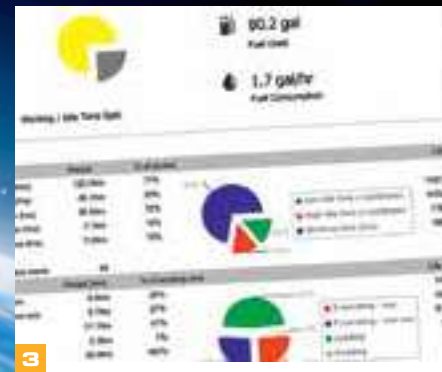

3



4

VALUE ADDED.

JCB'S WORLDWIDE CUSTOMER SUPPORT IS FIRST CLASS. WHATEVER YOU NEED AND WHEREVER YOU ARE, WE'LL BE AVAILABLE QUICKLY AND EFFICIENTLY TO HELP MAKE SURE YOUR MACHINERY IS PERFORMING TO ITS FULL POTENTIAL.



1 Our Technical Support Service provides instant access to factory expertise, day or night, while our Finance and Insurance teams are always on hand to provide fast, flexible, competitive quotes.

2 The global network of JCB Parts Centers is another model of efficiency; with 16 regional bases, we can deliver around 95% of all parts anywhere in the world within 24 hours. Our genuine JCB parts are designed to work in perfect harmony with your machine for optimum performance and productivity.



3 JCB Product Support offers comprehensive extended warranties and service agreements, as well as service-only or repair and maintenance contracts. Irrespective of what you opt for, our maintenance teams around the world charge competitive labor rates, and offer non-obligation quotations as well as fast, efficient insurance repair work.

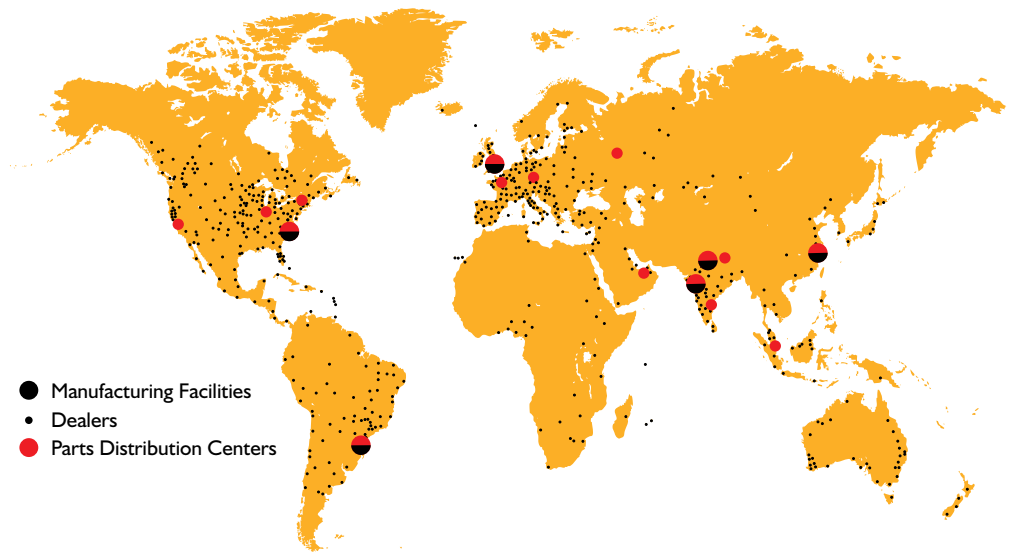

STATIC DIMENSIONS

Max. Engine power: 74hp (55kW) max. tool carrier dig depth: 14' 3" (4.33m)

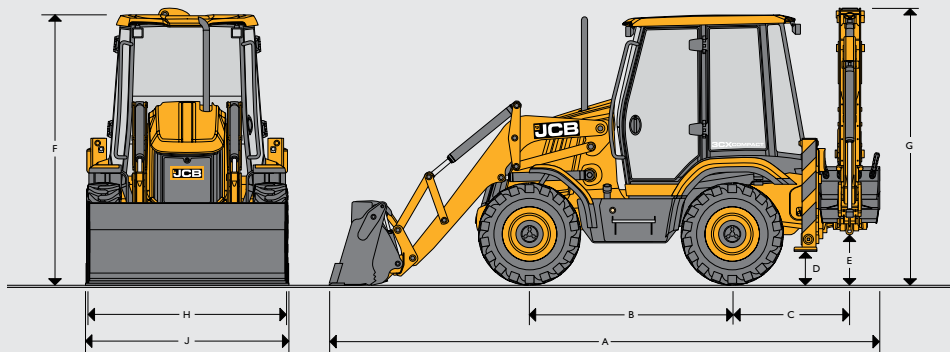

		3CX COMPACT	
A	Total travel length	ft-in (m)	18-2 (5.54)
B	Axle centerline distance	ft-in (m)	6-6 (1.99)
C	Slew center to rear axle center distance	ft-in (m)	3-11 (1.21)
D	Stabilizer feet clearance	ft-in (m)	0-9 (0.24)
E	Kingpost clearance	ft-in (m)	1-6 (0.47)
F	Cab roof height	ft-in (m)	8-6 (2.60)
G	Total travel clearance (10ft)	ft-in (m)	9-0 (2.74)
	Total travel clearance (12ft)	ft-in (m)	10-1 (3.07)
H	Rear frame width	ft-in (m)	6-2 (1.89)
J	Loader bucket width	ft-in (m)	6-6 (2.00)

JCB tool carriers feature heavy-duty one piece mainframe, hydrostatic driveline and fully enclosed engine compartment. All fluid and component compartments are lockable using the ignition key

GROUND LINE ANGLES

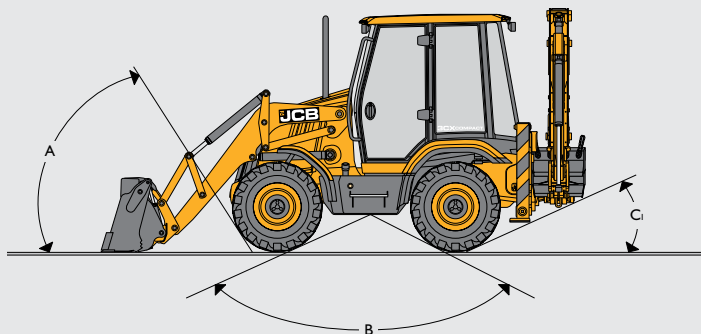

A	Approach angle	degrees	45°
B	Interference angle/ramp to ground plane	degrees	124.5°
C	Departure angle	degrees	19°

ENGINE

Common rail diesel. Belt driven water pump. Cold start aid – territory dependent. Single side servicing.

Engine emissions	T4/Stage IIIB	
Manufacturer	JCB Diesel by Kohler Co.	
Gross power	hp (kW)	74 (55) @ 2200rpm
Peak torque	lbf (Nm)	221 (300)
Aspiration	Turbo charged	
Displacement	Liters (cc)	2.5 (2482)
No. of cylinders	4	
Bore	Inches (mm)	3.46 (88)
Stroke	Inches (mm)	4 (102)
Rated engine	rpm	2350

ENGINE SUPPORT SYSTEM

Engine support system is designed for ease of daily checks, routine maintenance and longer service intervals.

Fuel type	Diesel	
Fuel filter	Replaceable spin-on cartridge plus water/sediment separator.	
Air cleaner	Dual, dry element type, with self cleaning internal air intake precleaner.	
Oil filter and lubrication	Full flow, spin-on filter	
Cooling system	Hot climate specification, pressurised 14.5 psi (1.0 bar) suction fan. Pressurised recovery tank.	

ELECTRICAL AND INSTRUMENTATION

12 volt negative ground, utilizing wiring and connectors meeting IP69 water ingress test standard. Central fuse panel supplemented with main circuit breakers at battery positive terminal.

Gauges	Speedometer, engine speed, engine coolant temp, fuel level, hourmeter clock	
Warning system	Audible and visual system for engine oil, transmission, park brake, battery, air cleaner, alternator	
Battery	900 CCA/110 A/hr.	
Pre-wire	Radio speaker (cab), beacon (all)	
Horn	Controlled from both front and rear	
Alternator	100 amp	
Front working lights	2 Halogen adjustable	
Rear working lights	4 Halogen adjustable	

TRANSMISSION

Bosch Rexroth transmission with anti-stall and high speed roading switch.

Type	Hydrostatic	
Model	Rexroth A6VM – 3 speed	
1st (low range)	mph (km/h)	3.7 (6)
2nd (high range)	mph (km/h)	6.2 (10)
3rd (high speed)	mph (km/h)	24.9 (40)

SERVICE CAPACITIES

Cooling system	Gal (liters)	4.22 (16)
Fuel tank	Gal (liters)	21.1 (80)
Engine oil sump	Gal (liters)	2.95 (11.2)
Hydraulic system (including transmission)	Gal (liters)	27.47 (104)
Rear axle	Gal (liters)	2.37 (9.0)
Front drive axle	Gal (liters)	2.37 (9.0)

AXLES

	Front	Rear
Type	JCB Max-trac steer drive torque proportioning	
Axle ratings	lbs (kg)	
Static load rating	16500 (7484)	
Dynamic load rating	8300 (3765)	
Oscillation angle	9.5°	—
Steering ram	Double acting	Double acting

STEERING

Steering axles	Front and rear
Steering turns – lock to lock	4
Turning diameter:	ft-in (m)
Inner wheels braked	19 (5.8)
Inner wheels not braked	21-11 (6.7)

OPERATING WEIGHTS

10ft Extending Dipper and Cab/AC	lbs (kg)	13382 (6070)
12ft Extending Dipper and Cab/AC	lbs (kg)	13514 (6130)
For Fixed Dipper	lbs (kg)	-496 (225)
For Canopy	lbs (kg)	-165 (75)

Operating weight includes machine with 6-in-1 shovel, 600mm excavator bucket, extended dipper, full fuel tank and operator. Actual weight will vary depending on machine options.

BRAKES

The JCB braking system ensures effective, fade free braking. The self-adjusting, multi-disc arrangement is inboard mounted and is oil immersed for minimum maintenance and a long operating life.

- Split brake pedals provide tighter turning circle and enhanced steering control on slippery ground.
- Automatic compensation ensures 'straight' machine braking.
- Disc diameter: 6.5in (165mm). Friction area: 202 sq.in (130502 sq.mm) per brake.
- The independent parking brake is mounted on the input shaft rear axle and will hold the machine on 1:2 gradients. High-retraction brakes and transmission disconnect reduce power loss and brake pad wear.

HYDRAULIC SYSTEM

Closed center system (piston pump) offering variable flow hydraulics, providing best in class controllability. ISO control system with a new Eco excavating mode for fuel saving.

Pump flow at 2350rpm	gal/min (l/min)	26.4* (100*)
System relief pressure	psi (bar)	3336 (230)

*100% efficiency

TIRES

340/80 x R18 Michelin XMCL (Radial)

340/65 x R18 Michelin XP27 Turf Tire (Radial)

340/80 x 18 Michelin Power CL (Cross-ply)

NOISE AND VIBRATION LEVELS

Internal	dB(A)	71
External	dB(A)	101

CAB

- Excellent visibility (and safety) is provided by the extra large tinted glass areas. Cab frame is ROPS and FOPS approved for maximum operator protection. ISO standard 3471 and 3449 (SAE J11040 and J231).
- A fully adjustable air suspension seat combines with ergonomically positioned controls to minimize operator fatigue.
- A single DIN radio location is provided as standard plus twin speakers for stereo sound.
- Cab provides easy access through a left hand single door. Standard features include: retractable seat belt, 3 speed fresh air / recycle heater, front and rear screen wash / wipers (cab), front and rear horn, exterior mirrors and flat easy-clean floor.
- Dual instrument panels in the front console for roading and the side console for loading and excavating.
- Fixed steer column.
- Large protected opening rear window (cab).
- 12V power supply.

OPTIONS

Extending dipper, Air Conditioning, Keypad Immobilizer, 1T Lifting Shackle, Mechanical Excavator Quick Coupler, Mechanical Excavator Quick Coupler with 1T Lifting Shackle, 6-in-1 Clam Ram Guards, Quick Coupler Mounted Frame and Forks, Hand Held Tool Circuit, 9M Hose Reel with Hand Held Tool Circuit, 6-pack LED lights, 10-pack LED Lights, Rotating Amber Beacon, Rear Fog Light, Engine Block Heater, Front Fenders, Extra Bucket Pin Set

LOADER DIMENSIONS

	G.P. Shovel	6-in-1 shovel	Narrow G.P. shovel
	ft-in (m)	ft-in (m)	ft-in (m)
Overall width with bucket	6-6 (2.00)	6-6 (2.00)	4-6 (1.37)
M Dump height	7-11 (2.41)	7-7 (2.32)	7-8 (2.35)
N Load over height	9-7 (2.93)	9-9 (2.98)	9-8 (2.96)
O Loader hinge pin height	10-5 (3.18)	10-5 (3.18)	10-5 (3.18)
P Pin forward reach	1-4 (0.4)	1-4 (0.4)	1-4 (0.4)
Q Reach at ground (toe plate horizontal)	5 (1.54)	5 (1.54)	5-2 (1.58)
R Max. reach at full height	3-8 (1.11)	3-8 (1.11)	4-0 (1.24)
S Reach at full height fully dumped	2-1 (0.64)	2-6 (0.78)	2-7 (0.79)
T Dig depth	0-5* (0.12*)	0-5* (0.12*)	0-5* (0.12*)
U Roll back at ground	45°	45°	45°
V Dump angle	45°	45°	45°
Jaw opening width	-	2-3 (0.7)	-

*With quickhitch.

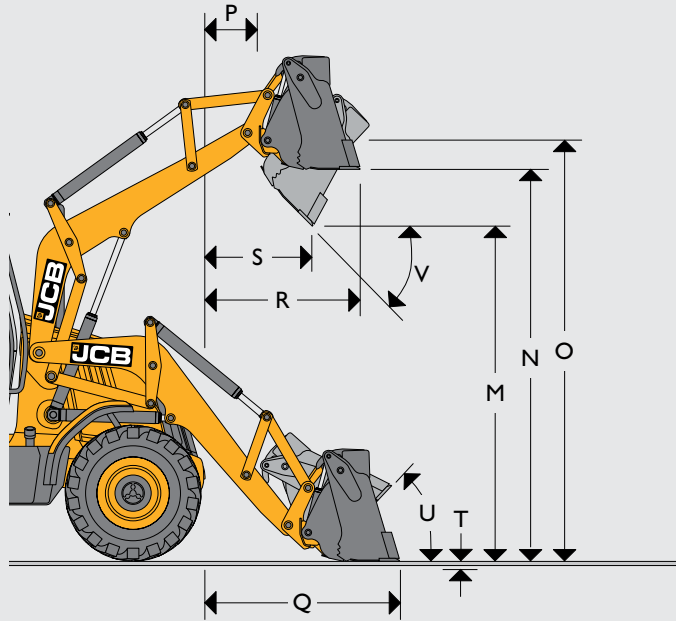

LOADER ATTACHMENTS

	Quickhitch Mounted forks
	ft-in (m)
W Forks – tine length	4-1 (1.24)
X Forks reach at ground level	7-2 (2.19)
Y Forks reach at full height	5-11 (1.79)
Z Forks lift height – max.	10-7 (3.24)
Fork spacing – min.	0-6 (0.15)
Fork spacing – max.	4-2 (1.28)
SWL @ 1' 8" load centers (lbs)	3582 (1670)
Max. rollback at ground (°)	9.8
Forks – tine width	0-4 (0.1)

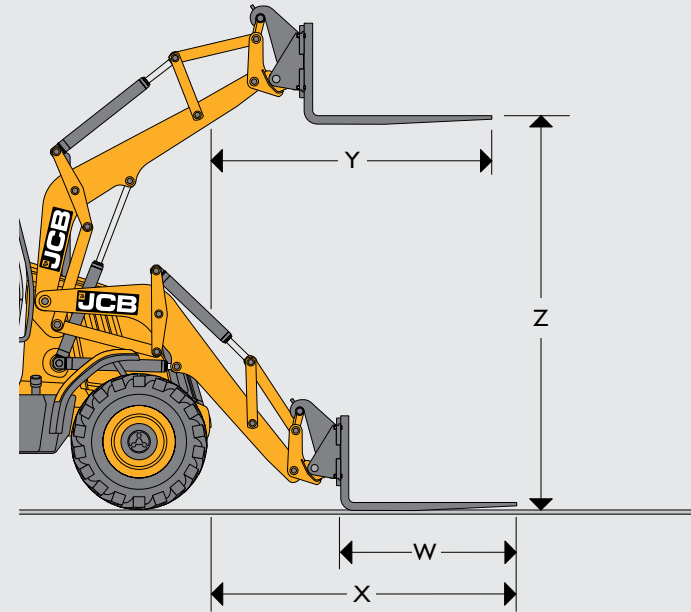

LOADER PERFORMANCE

		GP Shovel	6 in 1 Shovel
Loader breakout – loader bucket	lbf (kgf)	8285 (3758)	7976 (3618)
Loader breakout – arms	lbf (kgf)	5639 (2690)	5622 (2550)
Rated operating capacity*	lb (kg)	3364 (1526)	3056 (1386)

*Rated operating as determined according to ISO 14937:2007.

LOADER ATTACHMENTS – SHOVELS

All loader shovels are drilled to accept optional auxiliary cutting edge or teeth. Flat top box section provides rigidity and assists in bucket levelling.

	Shovel Capacity SAE	
	Rated yd ³ (m ³)	Struck yd ³ (m ³)
G.P. shovel 78in (2000mm)	0.92 (0.7)	0.73 (0.56)
6 in I shovel 78in (2000mm)	0.78 (0.6)	0.64 (0.64)
Narrow G.P. shovel 54in (1370mm)	0.78 (0.6)	0.64 (0.64)

EXCAVATOR ATTACHMENTS – BUCKETS

JCB Backhoe buckets are designed specifically for use on JCB machines with pin positions to maximize tearout, load retention and straight wall digging characteristics.

Width Inches	Capacity SAE	
	Rated yd ³ (m ³)	Struck yd ³ (m ³)
9	0.036 (0.028)	0.029 (0.022)
12	0.039 (0.03)	0.039 (0.03)
14	0.052 (0.04)	0.039 (0.03)
16	0.065 (0.05)	0.052 (0.04)
18	0.078 (0.06)	0.065 (0.05)
24	0.12 (0.09)	0.092 (0.07)
30	0.14 (0.11)	0.12 (0.09)
47	0.21 (0.16)	-

EXCAVATOR ATTACHMENTS – BREAKERS

	Weight lbs (kg)	Impact energy J
HM026T	573 (260)	1052

EXCAVATOR PERFORMANCE

			10ft Fixed	10ft Extending	12ft Fixed	12ft Extending
			lbf (kgf)	lbf (kgf)	lbf (kgf)	lbf (kgf)
Bucket breakout force	Ext		7363 (3340)	7363 (3340)	7363 (3340)	7363 (3340)
	Ret		-	5225 (2370)	-	5357 (2430)
Dipper breakout force	Ext		6102 (2770)	6327 (2870)	6041 (2740)	6327 (2870)
	Ret		-	1257 (570)	-	728 (330)
Lift capacity of bucket pivot at full reach	lb (kg)		2050 (930)	1521 (690)	1609 (730)	1080 (490)

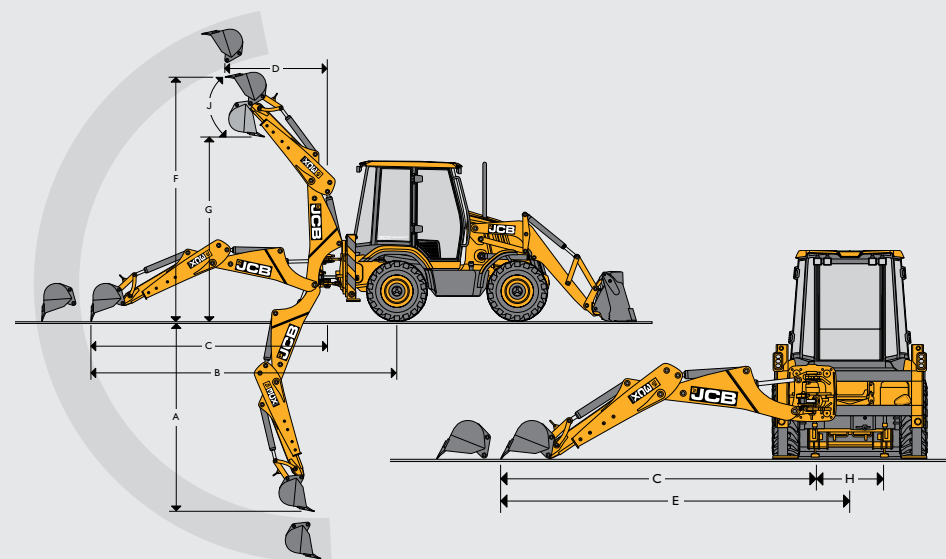
EXCAVATOR DIMENSIONS

			10ft Standard dipper	10ft Extradig	12ft Standard dipper	12ft Extradig
			ft-in (m)	ft-in (m)	ft-in (m)	ft-in (m)
A	SAE max dig depth	ft-in (m)	Ext 10-1 (3.07)	12-3 (3.72)	11-10 (3.68)	14-3 (4.33)
			Ret -	10-1 (3.07)	-	11-10 (3.68)
	SAE 2ft flat bottom	ft-in (m)	Ext 10-0 (3.04)	12-2 (3.70)	11-10 (3.61)	14-0 (4.26)
			Ret -	10-0 (3.04)	-	11-10 (3.61)
B	Reach – ground level to rear wheel center	ft-in (m)	Ext 17-0 (5.19)	19-0 (5.81)	19-1 (5.82)	21-1 (6.43)
			Ret -	17-0 (5.19)	-	19-1 (5.81)
C	Reach – ground level to slew center	ft-in (m)	Ext 13-1 (3.99)	15-1 (4.60)	15-1 (4.61)	17-1 (5.22)
			Ret -	13-1 (3.99)	-	15-1 (4.60)
D	Reach – at full height to slew center	ft-in (m)	Ext 3-9 (1.14)	6-3 (1.90)	8-9 (2.67)	10-4 (3.16)
			Ret -	4-8 (1.41)	-	8-9 (2.67)
E	Side reach – to center line of machine	ft-in (m)	Ext 14-6 (4.43)	16-7 (5.05)	16-11 (5.15)	18-10 (5.73)
			Ret -	14-6 (4.43)	-	8-9 (2.67)
F	SAE operating height	ft-in (m)	Ext 13-3 (4.05)	14-6 (4.43)	15-0 (4.57)	16-3 (4.95)
			Ret -	4-05 (4.05)	-	15-0 (4.57)
G	Maximum loadover height	ft-in (m)	Ext 9-0 (2.75)	10-7 (3.22)	10-10 (3.30)	12-3 (3.72)
			Ret -	9-0 (2.75)	-	10-10 (3.30)
	SAE loadover height	ft-in (m)	Ext 12-3 (2.72)	10-5 (3.18)	10-9 (3.27)	12-1 (3.68)
			Ret -	8-11 (2.71)	-	10-8 (3.26)
H	Total kingpost travel	ft-in (m)	3-3 (1.00)	3-3 (1.00)	3-3 (1.00)	3-3 (1.00)
J	Bucket rotation		187°	187°	187°	187°

A FEW WORDS ABOUT JCB.



Lord Bamford, the son of Mr. JCB, still runs the company today.

A family company on a global scale

JCB is no ordinary company. From the dreams of one man, Joseph Cyril Bamford, we have grown into the world's largest privately owned construction equipment company by volume. Since 1945, the same attention to detail, passion for progress and family spirit has taken us from strength to strength. Nowadays, JCB operates across all five continents, manufacturing at 22 factories in the UK, Brazil, Germany, China, North America and India. With 1,500 dealerships and depots selling and supporting our products in over 150 countries, we are one of the top three manufacturers of construction equipment with some of the finest engineering facilities in the world.

A history of world-class innovation

Our business has always been driven by innovation, using only the most advanced technology, components and processes, meticulous design and rigorous testing. Evidence of this doesn't come much more powerful than our revolutionary JCB Dieselmox engine. Having grabbed the headlines when it smashed the world land speed record at 350.092mph, it is now providing our customers with tomorrow's performance today.

Sustainability in all we do

As a manufacturer of working machinery, operating in both established and emerging markets, we accept the challenge of helping to deliver economic

and environmental sustainability. Product innovations that provide the right solutions to our customers have been a vital part of our history and will be key to our sustainable future. But in addition to developing cleaner and more efficient machines, we have a commitment to ensuring our manufacturing facilities meet the highest environmental standards.

A commitment to our customers that goes on

That's a fact we remind ourselves of constantly, and it's the reason our customers are at the heart of everything we do. Whatever a customer needs, we make it our mission to provide world-class support and 100% satisfaction. At the heart of this is a dedication to minimizing machine downtime. So our state-of-the-art World Parts Center dispatches more than a million genuine parts and attachments every week, with an 'Anywhere in 24 hours' strategy. Our JCB-trained technicians provide excellent, expert customer care, whether it's routine servicing or something more urgent.



Almost 1 out of every 2 backhoe loaders sold in the world is a JCB.

1940's



Joseph Cyril Bamford builds his first two-wheeled tipping trailer using a war-surplus Jeep axle and wheels in this rented garage in the United Kingdom.

1950's



JCB continues to expand its product line and moves its factory to larger quarters. By inventing the first backhoe loader, JCB revolutionizes the construction industry by giving contractors access to simple, powerful earthmovers.

1960's



JCB expands its factory, virtually doubling production capabilities. The company launches the forerunner of today's Jet Visit Program, acquiring an airplane and flying in customers for factory tours.

1970's



As demand for JCB products soars, the company exports its machines to Germany, Holland, Italy, Spain and Canada. JCB's Loadall Telescopic Handler revolutionizes the building industry by enabling bricks to be lifted on pallets.



Built in 2000, the JCB North American Headquarters in Savannah, Georgia supports all United States and Canadian dealers and manufactures 18 skid steer and compact track loader models.

JCB in North America

JCB has been in North America for over 40 years, but made a huge commitment to the market in 2000, when the North American business and manufacturing center was built in Savannah, Georgia. From this 500,000 square foot facility, JCB supports over 120 dealers in the United States and Canada, providing parts, training and expertise. The Savannah manufacturing floor produces 18 skid steer and compact track loader models.

From Savannah, we are also proud to manufacture the High Mobility Engineer Excavator (HMEE), a high-speed, fully armored backhoe loader currently in use by the U.S. Army.

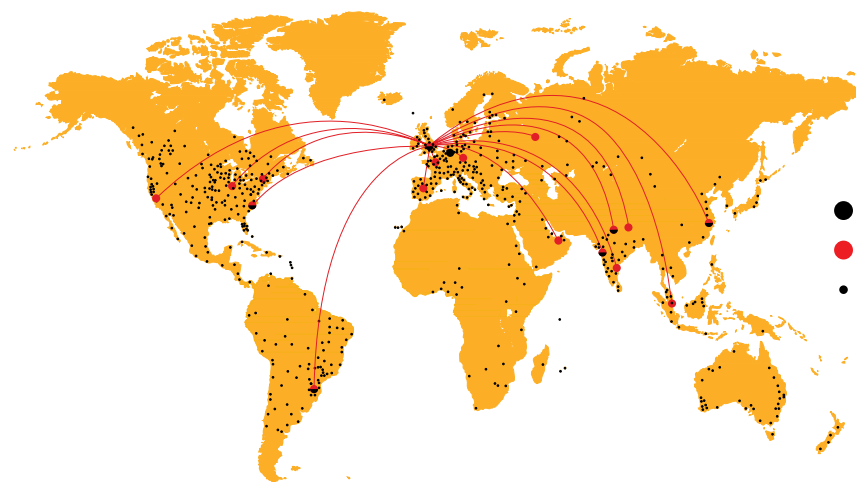

- Manufacturing Facilities
- Parts Distribution Centers
- Dealers

To find out more about the full range of JCB construction equipment, and to find the dealer nearest you, please visit www.jcb.com.



Built in Savannah, the fully armored JCB High Mobility Engineer Excavator (HMEE) is the world's toughest backhoe.

2 YEAR WARRANTY

Protection comes standard

- Industry's best standard 2-year warranty
- Includes 3-year structural warranty
- Full JCB machine range covered
- First year warranty covers unlimited hours, second year covers up to 2000 hours

JCB is committed to the best aftersales support in the industry. The 2 year standard warranty can be serviced by any authorized JCB dealership and is transferable during the standard 2 year period.



1980's



JCB expands its product range to wheeled and tracked excavators. The company develops the first – and still the only – true, high-speed tractor, the Fastrac. JCB launches its telescopic handler in the U.S.

1990's



The revolutionary monoboom skid steer is introduced to the compact range of equipment, quickly heralded as safe because of its unique side-door entry.

2000's



JCB builds its North American headquarters near Savannah. The JCB DieselMax engine breaks the land speed record. The company begins manufacturing its own diesel engines. The U.S. Army contracts 800 HMEES, to be built in Savannah.

Tomorrow

JCB's commitment to be 'Never Content' will remain. We will continue to develop innovative machines that will better help our customers get the job done. Our family of dealers will continue to grow, ensuring you world-class service and support no matter where you operate your JCB.



ONE COMPANY, OVER 300 MACHINES.

BACKHOE LOADER 3CX COMPACT

Gross power: 74hp (55kW) Maximum dig depth: 14'-2" Weight: 13382lbs

JCB North American – Headquarters

2000 Bamford Blvd., Savannah, Georgia, 31322 Tel: (912) 447-2000

Download the very latest information on this product range at www.jcb.com

JCB inc. All rights reserved. No part of this publication may be reproduced, stored in a retrieval system, or transmitted in any form or by any other means, electronic, mechanical, photocopying or otherwise, without prior permission from JCB inc. All references in this publication to operating weights, sizes, capacities and other performance measurements are provided for guidance only and may vary dependant upon the exact specification of machine. They should not therefore be relied upon in relation to suitability for a particular application. Guidance and advice should always be sought from your JCB Dealer. JCB reserves the right to change specifications without notice. Illustrations and specifications shown may include optional equipment and accessories. The JCB logo is a registered trademark of J C Bamford Excavators Ltd.

Your nearest JCB Dealer

