

# ORWAK FLEX 4360

FLEX

## COMPACT GENERAL WASTE IN 96 GAL BINS IN OUR NEW WASTE COMPACTOR FLEX 4360!

It is a robust and reliable machine with a compact and lightweight design. The 4360 is easy, safe and convenient to use! The multiple-chamber unit offers a top-loading setup, while the single-chamber version is based on the principle "Roll in! Compact! Roll out!".



## Safety

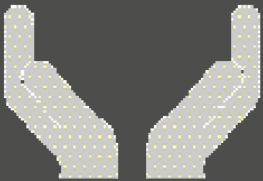

## Orwak benefits

### MORE PRODUCTIVE USE OF TIME

Less time spent on waste handling, more time for your core activities!

### MORE SPACE & ORDER

Our balers rapidly minimizes the space the waste takes up, keeping aisles free and tidy.

### LESS COSTS, MORE VALUE

More compaction = less waste volume to transport. Fewer transports required results in lower transportation costs and reduced CO<sub>2</sub> emissions. Sorting at source yields a higher quality of waste material for recycling.



## Why Orwak Flex?

- + Versatile compaction for many different application areas
- + Hygienic and safe compaction and disposal of mixed or hazardous waste
- + Special solutions for special needs

# ORWAK FLEX 4360

Smart in-bin compaction solution

## ORWAK FLEX 4360 IS OPTIMIZED FOR:

### SEMI-DRY WASTE

+ General waste

*Best suited for dry or semi-dry waste destined for landfill or incineration*

ORWAK FLEX 4360 is an in-bin waste compactor for standard two-wheeled 96 gal bins.

### IDEAL FOR GENERAL WASTE

The 4360 is perfect for the hotel and restaurant sector, where general waste needs to be disposed of in waste bins. The in-bin compactor provides impressive volume reduction, contributing to valuable space-saving and a more profitable waste management.

### SAFE AND USER-FRIENDLY

Model 4360 is user-friendly! The multi-chamber version is a convenient top-loading installation, while the single-chamber version has an easy wheel-in, wheel-out operation. Safety and quality are our hallmarks and the compactor provides maximum personal safety both for the operator and those in the immediate vicinity. A bin indicator assures that the machine can only start, when the bin is in the right position.



Designed to fit the standard 96 gal bins in the market.

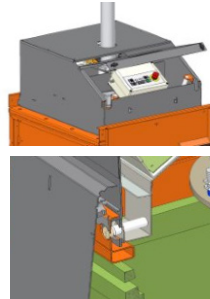

Full protection and no access to moving parts: safety switches on the hatch and the front door/apron

### SMART DESIGN - EASILY EXTENDABLE

The 4360 is a robust and stable machine that, thanks to its compact design, occupies little floor space. A good finish and easy access make cleaning quick and easy.

The compactor is easily extended with additional chambers. The front door on the single-chamber unit is then replaced by an apron for effortless movement of the press head from one chamber to the next.



The single-chamber unit with swing door



The multiple-chamber unit equipped with an apron with two handles

## DIMENSIONS & SPECIFICATIONS

### DIMENSIONS ORWAK FLEX 4360

A	B	C	D	TRANSPORT HEIGHT
Single: 7' 5"	Single: 37.4"	Single: 38.6"	Single: 70.5"	Single: 6' 11"
Double: 7' 5"	Double: 74.8"	Double: 41.7"		Double: 6' 11"

### MACHINE WEIGHT

TOTAL WEIGHT	PRESS UNIT	SINGLE STAND
Single: 528 lbs	264 lbs	264 lbs
Double: 792 lbs		

### TECHNICAL SPECIFICATIONS

BIN SIZE	CYCLE TIME	PRESS FORCE	NOISE LEVEL	PROTECTION CLASS	OPERATING POWER
96 gallon	29 secs	3,300 lbs	62.3 db (A)	IP 55	Single phase 115 V, 60 Hz, 16 A

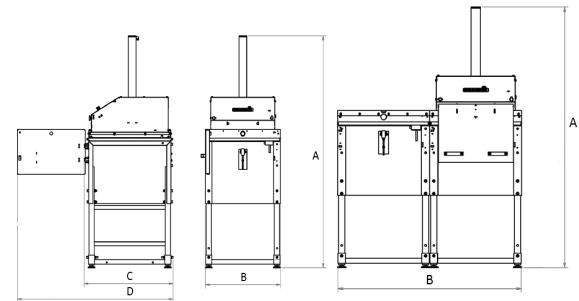

We reserve the right to make changes to specifications without prior notice. Bale/bag/bin weights are dependent upon material type.

### Orwak North America, Inc.

9200 Globe Center Drive, Suite 130, Morrisville, NC 27560, USA  
Phone: +1-800-747-0449, Email: info@orwakbalers.com

