

ORWAK

FLEX 5030-NHD

FLEX

THIS SPECIAL VERSION OF THE ORWAK

FLEX 5030 provides you with a safe way of compacting hazardous waste directly into drums.



Safety



Orwak benefits

MORE PRODUCTIVE USE OF TIME

Less time spent on waste handling, more time for your core activities!

MORE SPACE & ORDER

Our balers rapidly minimizes the space the waste takes up, keeping aisles free and tidy.

LESS COSTS, MORE VALUE

More compaction = less waste volume to transport. Fewer transports required results in lower transportation costs and reduced CO₂ emissions. Sorting at source yields a higher quality of waste material for recycling.



Why Orwak Flex?

- + Versatile compaction for many different application areas
- + Hygienic and safe compaction and disposal of mixed or hazardous waste
- + Special solutions for special needs

ORWAK

FLEX 5030-N HD

Safe waste handling

ORWAK FLEX 5030-N HD IS OPTIMIZED FOR:

OTHER MATERIAL

+ Hazardous waste

ORWAK FLEX 5030-N HD, a robust and reliable compactor, the handling, transportation and disposal of chemical waste becomes safe and simple. It compacts hazardous waste, such as glass and cans/tins containing residual paint, oil or chemicals directly into drums.

HIGH COMPACTION RATIO ON THE SPOT

The 5030-N HD is a compact machine with a small footprint, but even though it requires little space, it still offers a high compaction ratio of up to 10:1!

STEEL PALLET

A steel pallet is included for stable placement of the drum inside the compactor. The operator effortlessly handles the heavy-duty steel pallets using a standard pallet lifter.

Standard drums can be used for storage and transport of the hazardous waste. Sorting is possible by using several drums.



USER FRIENDLY

It is easy to feed material into the open top-loading unit. The compactor is safe and simple to operate.



DIMENSIONS & SPECIFICATIONS

DIMENSIONS ORWAK FLEX 5030-N HD

A	B	C	D	E
2165 mm	850 mm	1290 mm	2030 mm	1320 mm

ENERGY CONSUMPTION

STANDBY MODE	MAXIMUM OPERATION ONE HOUR
---	660 W/H

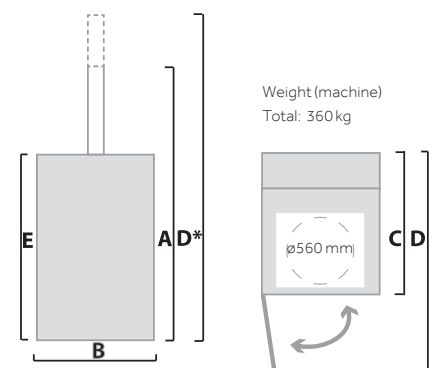

TECHNICAL SPECIFICATIONS

LOADING APERTURE	CYCLE TIME	PRESS FORCE	DRUM SIZE	NOISE LEVEL	PROTECTION CLASS	OPERATING POWER
ø 560 mm	36 secs	3 ton, 30 kN	Width: ø600 mm Height: 1005 mm	70 db (A)	IP 55	Single phase 230 V, 50 Hz, 10 A

We reserve the right to make changes to specifications without prior notice. Bale/bag/bin weights are dependent upon material type.