

# **Hako**

*Clean ahead*



***Municipal Technology***

***Multi-functionality without compromise***

*Efficient all-season use*



Reliable, functional, safe, and stable in value out of tradition. These are the high standards both we and our machines are ready to measure up to.

### The efficient all-rounders

Spring, summer, autumn and winter: each season comes with its own specific challenges. We develop environmentally friendly vehicles for municipalities, service providers and industrial companies that meet changing requirements by providing powerful and efficient performance. Our focus is always the same: maximum customer satisfaction. Concentrating on our customers' individual and specific tasks enables us to offer the perfect solution for every application – efficient in practice, extremely flexible and comfortable to use.



### Hako: That's why!

Here is what you can expect from us: high-quality products, designed and made in Germany, that meet the highest demands in terms of material, technology and functionality. For you as our customer that means: efficient and robust work and transport machines you can rely on – under all conditions. This is ensured, inter alia, by our excellent service: locally and worldwide, around the clock, for maximum availability throughout the machine's entire service life – which is an important factor in guaranteeing lowest possible life cycle costs. Our products' consistent multi-functionality increases efficiency and reduces investment costs: all you need is just one machine that can be flexibly adapted and used for almost every application. And to top it all off, both our intelligent feature Hako-Fleet-Management-Solutions and our attractive financing alternatives make our products even more economically efficient. Add the highest level of safety and comfort to the mix, and experience how we have turned a high-quality product into an optimal solution. This is the high standard we have set ourselves in order to ensure our customers' success.

### Contents

<b>Municipal Technology made by Hako</b>	
Overview	4
<b>Citymaster</b>	
Implement carriers and city sweepers with articulated or all-wheel steering	6
<b>Multicar</b>	
Multi-functional narrow-gauge implement carriers and transporters	16
<b>Hako-Fleet-Management-Solutions</b>	
Online-based fleet management for increased safety and efficiency	24
<b>Financing</b>	
Attractive leasing, rental and financing models	26
<b>Service</b>	
Customised services for maximum machine availability	27



Superior technology, excellent service: this is how we create profitable solutions that pay off throughout our machines' service life.

**Safety first**

Tested and approved – Citymaster with ROPS-tested safety cabin and Multicar with DEKRA-certified 2-person safety cabin. Both our Citymaster and Multicar vehicles comply with the high standards required to obtain EC type approval and a general operating licence.



**The perfect solution for every application**

Our full-range product portfolio comprising implement carriers and city sweepers with either articulated or all-wheel steering as well as multi-functional narrow-gauge implement carriers and transporters measures up to this claim easily whilst putting safety, comfort, efficiency and environmental protection first.



	Citymaster				Multicar			
Model	CM 600	CM 1250plus	CM 1600	CM 2200	M27compact	M29	M31	M31 Hydrostat
Key characteristics	Implement carrier and sweeper with articulated steering in the 2-t class	Implement carrier and sweeper with articulated steering in the 2.5-t class	Implement carrier and sweeper with articulated steering in the 3.5-t class	Implement carrier and sweeper with all-wheel steering in the 6-t class	Transporter and implement carrier in the 3.5-t class	Narrow-gauge transporter and implement carrier in the 6-t class	Transporter and implement carrier in the 6-t class	Transporter and implement carrier in the 6-t class
Output	24 kW	33 kW	55 kW	80 kW	55 kW	80 kW	110 kW	108 kW
Driving licence	Class B	Class B	Class B	Class C/C1/C1E	Class B, 3,5 t (C/C1/C1E, 4,5 t)	Class C/C1/C1E	Class C/C1/C1E	Class C/C1/C1E



**Environment first**

Thanks to their low emission values and minimal noise level during operation, our vehicles can work even in environmental zones and other sensitive areas.

**Comfort first**

Multiply adjustable seats, ease-of-use and our quick-change systems are just a few of many excellent features that make our vehicles ergonomic and comfortable. This has also been confirmed by the AGR quality label being awarded to the Citymaster models 1600 and 2200 as well as the Multicar M29.

**Efficiency first**

The demands imposed on modern municipal technology could hardly be more diverse. So why specialise in just one individual application? Efficiency should you means that one machine can simply do more: as is the norm with vehicles made by Hako!



### A strong basis for various applications

No matter what the season or the application or the subsurface, or whether the conditions change constantly or you need to consider specific regional circumstances: the machines of our Citymaster range master every task efficiently. And they are highly flexible. Because, in addition to carrying out professional sweeping tasks, they can be re-tooled and equipped with a wide range of different attachments and chassis-mounted equipment for any kind of seasonal application – 365 days a year, from efficient cleaning to green area maintenance or winter service. That's what we call „One for All“. And our customers put it like this: the optimal machine for every application.

\* AGR quality label (Aktion Gesunder Rücken (AGR) e.V.): Tested and recommended by the German association Forum Gesunder Rücken – besser leben e.V. (German association promoting healthy backs) and Bundesverband deutscher Rückenschulen (BdR) e.V. (Federal Association of Back Training Facilities), for further information contact: AGR e.V., Stader Straße 6, 27432 Bremervörde, T: +49 (0) 4761- 92 63 580 www.agr-ev.de



Multi-functional working throughout the year: for example with attachments providing efficient maintenance of green areas and swift re-tooling enabled by the quick-change system.



Your strong partner also in the cold season: with all-wheel drive and attachment devices providing safe winter service applications.

# Citymaster

Implement carriers and city sweepers with articulated or all-wheel steering

#### Technology at its best – for all-season use

If you can hardly see or hear it, it's municipal technology at its best. Because it means that the machines carry out their tasks in a clean, rapid and efficient manner. The key factors are, for example, that the machines are as compact, manoeuvrable and flexible as possible while offering a high payload at the same time. Moreover, they need to be safe on the road and provide low-noise operation as well as lowest possible emission and consumption values combined with best possible dust control during sweeping. Hako's Citymasters offer you just that!



For even more efficient work results: driver's cabin with ergonomic comfort seats and one-hand operating system integrated in the armrest.



At a glance: the high-resolution colour display provides a good overview of the machine's current operating states and parameters.



Fast, easy, no tools needed: thanks to the quick-change system, the Citymaster can be re-tooled for the next job in no time at all.



Sweeping



Wet cleaning



Winter service



Green area maintenance



Transport



Scan to obtain further information.



### Small, highly manoeuvrable, universal

The pro in the class of compact machines expertly fulfils the requirements of service providers or gardeners and landscapers: equipped with our innovative quick-change system and a wide range of optional attachments and accessories available to meet individual customer requirements, the Citymaster 600 is the perfect machine for all-season use. And the vehicle's small width combined with its superior directional stability ensures optimal manoeuvring even in the smallest of work areas.



Quickly off to the next job site: on its own axles if the job is nearby, or transported on a trailer to cover larger distances.



Easy to change – comfortable, back-friendly changing of the hopper and different attachments via quick-coupling system and trolley.

## Citymaster 600

The compact all-rounder



Professional sweeper: with large adjustable brooms, powerful suction fan and a universal 600-litre capacity dirt hopper.



Highly variable when it comes to green area maintenance: with different mowers, grass collecting system, flail mowers or hedge trimmers.



Flexible when it comes to winter service applications: with the capacity to transport 400 kg of gritting material to ensure long operating times and with a wide range of attachments and accessories available.



25

Versatility, manoeuvrability, comfort – these are the characteristics that make the compact Citymaster 600 a master of all-season employment.

### Narrow gauge, wide range of applications

The compact 2-t-class implement carrier Citymaster 600 with articulated steering is equipped with convincing features and clever details providing high levels of multi-functionality and efficiency: for example the universal hopper made of high-strength aluminium, which can be used for sweeping and mowing tasks or as a supplementary water tank – with maximum payload. Or the permanent all-wheel drive ensuring controlled performance across the entire speed range. The basic unit has been equipped to guarantee the full level of functionality when the machine is used as a professional sweeper – and retrofitting is possible at any time with minimal effort!

### Compact on the outside, spacious on the inside

Both the comfortable seats and one-hand operating system make the Citymaster 600 an attractive workplace for the driver. The same goes for the large windows of the ROPS-tested safety cabin with ample headroom, which allow an excellent view onto the work area. Moreover, the Citymaster 600 provides added comfort for all-season use: thanks to the integrated heating system and optional air conditioning.



D = 1,39 m

The vehicle easily circumnavigates any obstacle: thanks to its compact dimensions, directionally stable steering and particularly small turning circle.

Technical data Citymaster 600	
Engine	Diesel, 24 kW
Engine drive (type / formula / Vmax.)	Hydrostat / 4x4 / 25 km/h
Exhaust emissions (standard)	97/68/EC, stage 3A
Interfaces / attachment points	quick-change system / 3
Hydraulics (work circuits / summation max. l/min / bar)	2 / 66 / 195
Sweeper (dirt hopper / working width)	600 l / 1,850 mm
Dimensions basic vehicle (L x W x H)	3,126 x 1,090 x 1,969 mm
Weight basic vehicle (GVW / payload max.)	2,200 kg / 850 kg
Driving licence	Class B



Scan to obtain further information.



# Citymaster 1250plus

The classic vehicle with an extra plus

## A winner on all fronts

More comfort, more functionality, more efficiency:  
The Citymaster 1250plus offers options that provide a big plus in every aspect. The driver profits from both ease-of-use provided by the one-hand operating system and superior driving comfort as well as reduced noise levels in the cabin whilst the operating company can capitalise on improved work results and increased efficiency – for example through the sweeping unit offering various adjustment options, variable working widths and an extended choice of sweeping brooms.



For both intensive and basic cleaning of traffic areas – even after accidents involving oil spills: combined cleaning with the CityCleaner scrub deck.



Well equipped for all cleaning tasks: with small brooms for narrow way-through widths or with large brooms providing maximum area performance.



Covers the full range of winter service tasks: from clearing snow to fighting black ice.



Easy cleaning of difficult-to-access areas: with the flexible hand tool for all cleaning tasks around the machine.



## More comfort – increased safety!

The combination of our optimised air-sprung driver's seat, smoothly rolling tyres and the operating panel integrated in the armrest ensures both comfortable working and pleasant transport journeys. These features not only make work easier for the driver, they also ensure increased safety: by providing fatigue-free working and allowing the driver to keep an eye on his work environment in any given situation.

Both the rubber-dampened cabin and optimised tyres ensure improved driving comfort and increased safety.

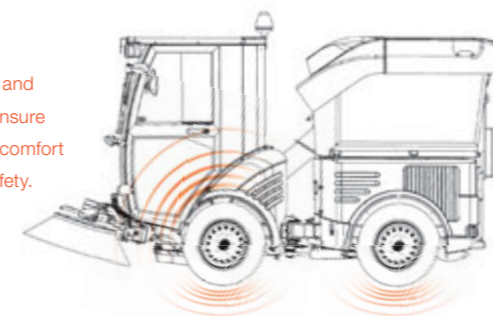

The robust implement carrier with articulated steering carries out all cleaning tasks fast and comfortably while ensuring particularly low-noise working.

## 2.5 t – class!

For cleaner cities: the fully integrated sweeper Citymaster 1250plus with 1-m<sup>3</sup> dirt hopper capacity is the ideal machine for municipal applications. Thanks to the new sweeping unit with its two optional features 'individual-broom-adjustment' and 'broom-head-adjustment' as well as different brooms available, the vehicle can be flexibly adapted to meet the requirements of all kinds of different operating conditions. Alternatively available with a CityCleaner scrub deck or a sluicing system for intensive wet cleaning tasks. And – being a typical Citymaster – it is a 'One for All' machine, which can be used to perform winter service tasks just as well as green area maintenance.

### Technical data Citymaster 1250plus

Engine	Diesel, 33 kW
Engine drive (type / formula / Vmax.)	Hydrostat / 4x2 (4x4) / 30 km/h
Exhaust emissions (standard)	97/68/EC, stage 3A
Interfaces / attachment points	quick-change system / 3
Hydraulics (work circuits / summation max. l/min / bar)	2 / 66 / 195
Sweeper (dirt hopper / working width)	1,000 l / 2,250 mm
Dimensions basic vehicle (L x W x H)	3,255 x 1,193 x 1,999 mm
Weight basic vehicle (GVW / payload max.)	2,600 kg / 1,115 kg
Driving licence	Class B



Scan to obtain further information.



Increased efficiency through short set-up times: changing the attachments or chassis-mounted equipment can be carried out by just one person and without the need for tools.

## Citymaster 1600

The multi-functional pro

### Great performance in a compact form

The features and functions of larger sweepers unified in a 3.5-t GVW machine: the compact sweeper Citymaster 1600 brings top performance to the roads, footpaths and green areas of the city. And the machine can do much more than sweeping roads professionally: equipped as a multi-functional implement carrier with a powerful and particularly efficient hydraulic system driving the attachments, there are virtually no limits to the vehicle's application options.



Safe driving characteristics also when fully loaded: provided by coil springs, shock absorbers and stabilizers.

And off you go: fast and easy starting of the machine's function via the 1-button operating system.



**Transport**  
Chassis-mounted equipment

- Sweeping
- Weed control
- Mowing
- Wet cleaning
- Snow clearing
- Gritting

**Gritting**  
Towed attachment device

Optimised for use in the city: ultra-modern sweeping technology with lowest possible noise and dust emissions combined with a low-emission engine.

Mowing-suction combination with a universal hopper: ideal for mowing lawns, maintaining roadside greenery and working close to the kerb on either roadside.

Powerful against ice and snow: the wide range of attachments available enables flexible adaptation to different snow and weather conditions.

### Ergonomic, back-friendly, safe

The cabin of the Citymaster 1600 offers an excellent workplace for the driver – tested and certified by independent bodies and recommended by the German AGR e. V.! In addition, coil springs, shock absorbers and stabilizers as well as the intelligent drive control and a disc brake system provide high levels of safety.

Technical data Citymaster 1600	
Engine (type / exhaust gas cleaning system)	Diesel, 55 kW / particle filter
Engine drive (type / formula / Vmax.)	Hydrostat / 4x4 / 40 km/h
Exhaust emissions (standard)	97/68/EC, stage 3B
Interfaces / attachment points	quick-change system / 3
Hydraulics (work circuits / summation max. l/min / bar)	2 / 100 / 195
Sweeper (dirt hopper / working width)	1,350 l / 2,250 mm
Dimensions basic vehicle (L x W x H)	3,830 x 1,210 x 1,970 mm
Weight basic vehicle (GVW / payload max.)	3,500 kg / 1,525 kg
Driving licence	Class B

### Setting the benchmark in the 3.5-t class

The Citymaster 1600 provides the means for efficient city cleaning, both on footpaths and public roads, by exploiting the full potential of a class B driving licence. Thanks to its directionally stable articulated steering, the smallest turning circle in its class and permanent all-wheel drive, the

Citymaster 1600 can work almost anywhere. Whether used exclusively as a compact sweeper or as a versatile implement carrier for all-season municipal tasks – this machine embodies Hako's entire wealth of experience in the field of municipal technology. One for All!



Class B driving licence





Scan to obtain further information.



## Citymaster 2200

The sweeping talent with added benefits



62



### Top of the range in the 6-t class!

With its working width of up to 2.60 m and a genuine 2-m<sup>3</sup> hopper capacity, the compact sweeper with all-wheel steering shows off its qualities when it comes to cleaning both large and small areas in a particularly time-efficient manner. Different sweeping systems, a CityCleaner scrub deck and a sluicing system are

available to provide thorough, dust-free cleaning. The machine has been awarded the Blue Angel ecolabel (RAL-UZ 59). With its top speed of 62 km/h, the Citymaster 2200 ensures fast arrival at the next job site – and can be driven on motorways and express roads.



Masters every challenge efficiently: equipped with either two or three sweeping brooms, the Citymaster 2200 cleans even difficult-to-access areas without effort.



Powerful against stubborn dirt: CityCleaner scrub deck for maximum cleaning results on paved or natural stone surfaces.



For effective weed control including direct collection of the removed weeds: optional supplementary functions and reinforced drives.

### Flexible technology, exact performance

Equipped with our professional broom control system as a standard – this is a great plus especially when working under difficult conditions. Comprehensive safety systems as well as the sweeping unit with integrated collision protection ensure low repair costs.



### Always ready for the next job

Developed to provide maximum efficiency, safety and flexibility when it comes to cleaning public areas: equipped with either a 2 or 3-broom sweeping system and the largest dirt hopper in its class, the Citymaster 2200 meets all requirements imposed on modern municipal technology. The quick-change system ensures that the sweeping unit can be swiftly replaced by other attachments – for example wet cleaning or winter service devices. One for All.



Nothing can be overlooked: optional camera systems allow the driver an additional 270° viewing angle – without having to avert his eyes from the task at hand.



Technical data Citymaster 2200	
Engine (type / exhaust gas cleaning system)	Diesel, 80 kW / particle filter, SCR cat
Engine drive (type / formula / Vmax.)	Hydrostat / 4x2 / 62 km/h
Exhaust emissions (standard)	EURO VI, stage C
Interfaces / attachment points	ball-coupling system / 2
Hydraulics (work circuit / summation max. l/min / bar)	1 / 100 / 225
Sweeper (hopper / working width)	2,200 l / 2,600 mm
Dimensions basic vehicle (L x W x H)	4,950 x 1,320 x 2,055 mm
Weight basic vehicle (GVW / payload max.)	6.000 kg / 2.460 kg
Driving licence	Class C/C1/C1E





Multicar M27compact

Multicar M29 

Multicar M31

# Multicar

Multi-functional implement carriers and transporters

## 365 days, countless applications – only one vehicle

Sweeping in the spring, green area maintenance in the summer, collecting leaves in autumn, providing winter service in the cold season or carrying out different transport tasks throughout the year – thanks to the interfaces suitable for universal use, the Multicar can easily be re-tooled for every application. A wide range of different attachments, driven by either the powerful on-board hydraulic or electrical systems, can be connected to the vehicle with effortless ease. Our customers decide what they want their Multicar to look like. – We will be happy to assist you in finding the right solution for your individual needs.



The basis for multi-functionality is our quick-change system – for example as a front lift with attachment plate according to DIN EN 15432-2 providing lifting, lowering and swivel functions to facilitate easy connection of front attachments.

Everything in view, all under control: centrally arranged operating elements and displays ensure both ease-of-use and short response times.

Made for the operator: adjustable seats, height-adjustable safety belts as well as an adjustable steering column – all very practicable features, especially when the vehicle is often operated by different drivers.

Optimal functionality at the push of a button: the buttons to operate, for example, the differential lock, all-wheel drive or crawler gear are all within easy reach.

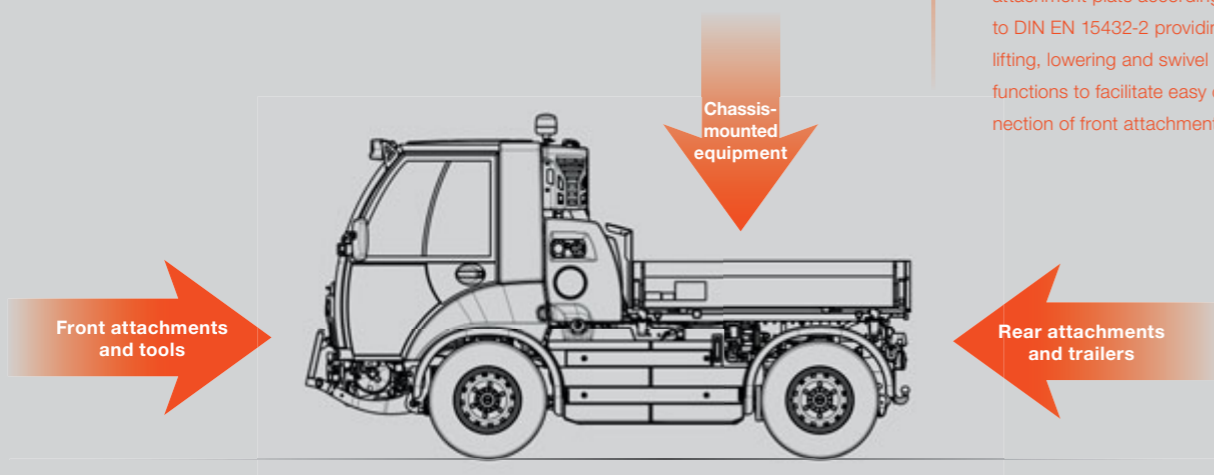

Green area maintenance



Sweeping



Winter service



Wet cleaning



Waste management



Transport



Road maintenance



Special applications



Fruit and wine growing

\* AGR quality label (Aktion Gesunder Rücken (AGR) e.V.): Tested and recommended by the German association Forum Gesunder Rücken – besser leben e.V. (German association promoting healthy backs) and Bundesverband deutscher Rückenschulen (BdR) e.V. (Federal Association of Back Training Facilities), for further information contact: AGR e.V., Stader Straße 6, 27432 Bremervörde, T: +49 (0) 4761- 92 63 580 www.agr-ev.de



Scan to obtain further information.



## Multicar M27compact

The 3.5-t class vehicle



And if you want to go that extra mile: in addition to the 3.5 t version, the Multicar M27compact is also available in a 4.5 t GVW variant – providing the same high level of comfort, safety and flexibility.



Perfectly equipped to carry out special applications: for example with a reflector post and crash barrier washer.

### Simply robust

Compact, powerful and versatile: the Multicar M27compact is the ideal entry-level vehicle for municipalities and service providers. Due to its GVW of 3.5 t (payload more than 1.0 t) the vehicle can be driven by anyone holding a class B driving licence. For the operating company this means having a full-featured work and transport vehicle available that requires no truck driving licence.



Class B driving licence



### Typical Multicar!

The Multicar M27compact combines both the efficiency and flexibility of an implement carrier with the comfort and reliability of a commercial vehicle. Being a typical Multicar, the vehicle can be upgraded from a compact transporter to a versatile implement carrier with both electrical and hydraulic functions in no time at all. Thanks to its small clearance width of only 1.62 m and the selectable all-wheel drive, the vehicle is ideally suited for working in difficult-to-access areas.



Servicing made easy: All components are within easy reach of the service technician.



Provides both more comfort and safety: independent suspension at the front axle.



Snow clearing? No problem at all! Equipping the vehicle with one of the different snow blades available turns the Multicar M27compact into a professional winter service machine.



Our flexible solution for superior outdoor cleaning: slicing bar for the wet cleaning of large areas.

### Comfortable driving, efficient working

Driving the Multicar M27compact is just as comfortable as driving a commercial vehicle: thanks to its 5-gear transmission, power steering, individually adjustable seats and the optimised interior design of the space-frame cabin with tinted panoramic windscreen. The vehicle's excellent driving characteristics combined with a 4-channel ABS and disc brakes conveys a feeling of safety in all driving conditions, especially when working with front attachments or driving at higher speeds.



Ensures speedy arrival at the next job site: the vehicle's top speed of 80 km/h allows travelling on motorways and express roads.

Technical data Multicar M27compact	
Engine (type / output / exhaust gas cleaning system)	Diesel, 55 kW / particle filter
Engine drive (type / formula / Vmax.)	5-gear / 2x4 (4x4) / 80 km/h
Exhaust emissions (standard)	97/68/EC, stage 3B
Attachment docking system	front lift, tipper crossbar, rear brackets
Work hydraulics	up to 2 work circuits (max. 80 l/min at 200 bar)
Electrics	up to 2 work circuits (12 V, max. 800 W)
Dimensions basic vehicle (L x W x H)	4,115 x 1,620 x 2,200 mm
Weight basic vehicle (GVW / payload max.)	3,500 kg / 1,300 kg or 4,500 kg / 2,300 kg
Driving licence	Class B / C/C1/C1E



Scan to obtain further information.



# Multicar M29

The compact all-rounder

## Sufficient space for maximum performance

Lack of space is almost never an issue when working with the Multicar M29: both the vehicle's small width of only 1.33 m and its small turning circle of only 3.25 m enable working in narrow lanes, on service roads and cemeteries, with payloads of up to 3.2 t. The hydrostatic drive with variable hydrostatic braking power going easy on the brakes when driving on steep downhill tracks is yet another huge benefit. And when working on inclines, mechanical conversion allows precise adjustment of the speed to provide additional power reserves.

Ease-of-use: of the machine's functions as well as the hydrostatic drive are easily and centrally controlled via a joystick.



High payload, little effort: quick installation of chassis-mounted equipment.



Superior performance: high-pressure cleaning in combination with a washing boom provides intensive cleaning of large areas.

There are many ways of clearing paths: the Multicar M29 masters them all – for example with the front sweeper.

Skip loader systems enable the alternating use of different transport containers – including high-dump hoppers.



The machine has the excellent manoeuvrability of a lorry implement carrier – and gets you around every corner easily thanks to all-wheel steering.



Economical in use – and quickly off to the next job site with a top speed of 62km/h: the Multicar M29.

## Great performance in all seasons

No matter what the challenge: thanks to its modular vehicle concept, the multi-functional narrow-gauge implement carrier Multicar M29 flexibly masters any seasonal task while providing the highest level of safety – the vehicle's safety concept is in line with the same high standards that apply in the truck construction industry. The cabin offers best possible occupant protection, which has been tested in accordance with the ECE R 29 standard and certified by DEKRA. To ensure both stable road-holding characteristics and safe braking in any given situation, the safety concept also includes all-wheel drive, disc brakes, our innovative hydrostat ABS as well as heavy-duty axles – tested and approved in accordance with ECE R 13.



### Technical data Multicar M29

Engine (type / output / exhaust gas cleaning system)	Diesel, 80 kW / particle filter, SCR cat
Engine drive (type / formula / Vmax.)	Hydrostat / 4x2 (4x4) / 62 km/h
Exhaust emissions (standard)	EURO VI, stage C
Attachment docking system	front lift, coupling triangle, attachment plate, tipper cross beams, rear attachment frame, rear power lift
Work hydraulics	up to 2 work circuits (max. 110 l/min at 300 bar)
Dimensions basic vehicle (L x W x H)	3,955 x 1,330 x 2,090 mm
Weight basic vehicle (GVW / payload max.)	6,000 kg / 3,200 kg
Driving licence	Class C/C1/C1E





Scan to obtain further information.



### Great performance in open terrain

Where highest demands for comfort and safety meet multi-functionality, efficiency and manoeuvrability, the result sets entirely new standards: as is the case with the Multicar M31. With its gross combination weight of up to 7.5 t, the powerful variable hydraulic system and three attachment points for a countless number of different attachment combinations, the vehicle not only provides powerful performance in the winter but works just as efficiently in spring, summer and autumn. And what's more, the Multicar M31 complies with all relevant guidelines relating to safe and reliable municipal employment, working on commercial premises or in the gardening and landscaping sector and fulfils the standards required to obtain EC type approval.

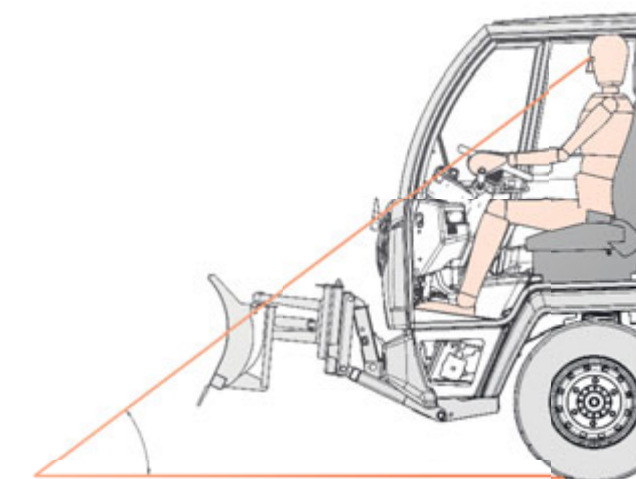

More space, a better view, increased safety: in the ergonomically designed space-frame cabin with panoramic windscreen and integrated sun-glare filter.

## Multicar M31

The full-fledged powerful pro



Snow fighter: efficient clearing of roads and paths.

Quickly re-tooled: efficient weed control with superheated steam.

No task is too special: the Multicar M31 can also be used to carry out work on sewers and canals.

Versatility only a Multicar can offer: from conventional tasks such as green area maintenance to carrying out repair work requiring a lifting platform.



Increased loading capacity, more room: the Multicar M31 is also available with a long wheelbase.

### Sophisticated technology in a robust design

High-quality workmanship on the outside, and equipped with a large number of clever details providing economical operation on the inside: the torsionally flexible light-steel frame makes this highly professional multi-functional implement carrier and transporter extremely durable – also in continuous operation. The powerful low-consumption and low-maintenance engine significantly reduces your operating costs. The Multicar M31's high transport speed of up to 90 km/h ensures efficient working hours.

### Comfortable workplace

Comfortable working increases efficiency – this is why we have integrated a number of comfort features into the Multicar M31 as a standard: from the smooth power steering to the spring-mounted independent spiral suspension and the ergonomic comfort cabin with individually adjustable seats and practical stowage spaces in the doors and centre console.



Optimised drive, maximum braking power: an innovative hydrostat ABS providing additional safety during braking is integrated in the model Multicar M31 Hydrostat. And the hydrostatic drive enables smooth but swift starting and infinitely variable propulsion.



Technical data Multicar M31	
Engine (type / output / exhaust gas cleaning system)	Diesel / 110 kW (Hydrostat: 108 kW) particle filter, SCR cat
Engine drive (type / formula / Vmax.)	5-gear / 4x2 (4x4) / 90 km/h (Hydrostat: 4x2 (4x4) / 70 km/h)
Exhaust emissions (standard)	EURO VI, stage C
Attachment docking system	front lift, ball coupling system, rear brackets
Work hydraulics	up to 2 work circuits (max. 110 l/min at 300 bar)
Dimensions basic vehicle (L x W x H)	4,115 (4,660) x 1,630 x 2,200 mm
Weight basic vehicle (GVW / payload max.)	5,600 kg / 3,100 kg
Driving licence	Class C/C1/C1E



Scan to obtain further information.

### Hako-Fleet-Recorder

Always up to date: Hako-Fleet-Recorder records both the machine's operating data and current condition. The recorded data enables fleet managers to authorise users and obtain information on the machines' current operating states to help reduce machine damage and optimise machine utilization. Additional benefit: Fleet-Recorder evaluations can be used as a performance record for customers. Detailed information just one click away – that's what we call modern machine management.



Operations centre smartphone: machine data – available at any given time.

## Hako-Fleet-Management-Solutions

Vehicle access authorisation via electronic key



### Dates. Facts. Overview.

The larger the number of machines in your fleet, the more important it is to have a good overview of all relevant key data in order to ensure efficient operation. Hako offers you an online-based fleet management system collecting all relevant key data for centralised access on your PC or smartphone.

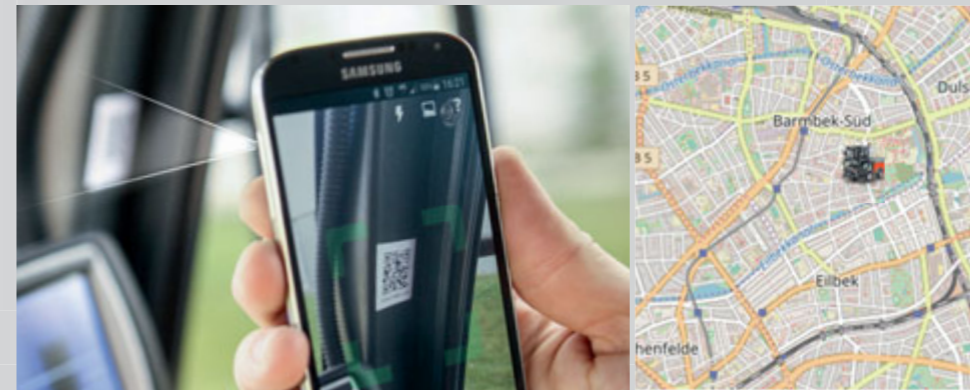

### Hako-Fleet-Report

All your economically important data available online in a compact format: machine and contract data, information on servicing and maintenance intervals as well as the servicing and job-site history of each machine in your fleet. The vehicle access authorisation can be configured individually via the electronic key. Individually configurable for different members of staff. And always up-to-date online. Hako-Online-Service supports fleet managers in using their machines more efficiently – with evaluations that are available around the clock and an intuitive user interface providing quick and easy retrieval of the stored data.





Scan to obtain further information.

### 24/7 machine availability!

Around 650 service technicians are on the road for you all across Europe. Maximum spare part availability and direct delivery to the technicians ensures fast and efficient service. Your benefit: minimised down times and maximum efficiency!

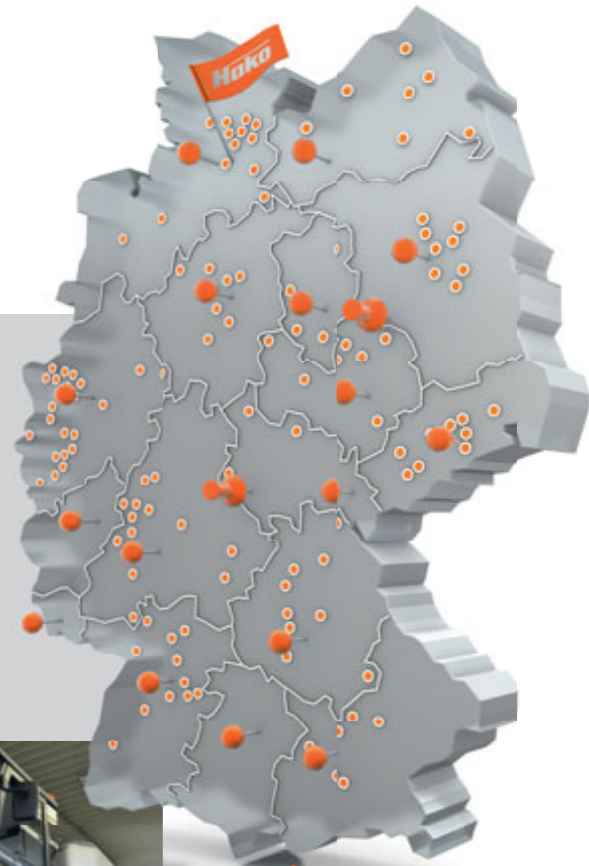

### Economically profitable cleaning

Buying? Renting? Leasing? Hako Finance offers clients interesting customised options to finance their machines. Our procurement alternatives include special financing models that are optimally adapted to suit both seasonal and project-based requirements. Or all-inclusive solutions offering financing, maintenance and insurance all from a single source. Yet another clean solution made by Hako.



Our comprehensive network of authorised service partners: always close to our customers throughout Germany.



Leasing options – customised to meet individual customer requirements.

Rental contract ALL-IN-plus: financing, maintenance and insurance included!

Adapt your rental payments to your seasonal earnings.

Hire-purchase – customised monthly payments in line with your liquidity.

### Service you can rely on

Our sales and service organisation is one of our greatest assets. We are always close to you to provide both qualified expert advice and reliable service – 24/7. To ensure smooth operation of your business – and make you feel at ease.



More than 650 service technicians – available around the clock all across Europe.



### Always in the front line

We constantly work on developing our solutions further to ensure our capability of satisfying tomorrow's demands: we keep a close dialogue with our customers and focus on current trends while bearing future requirements in mind at the same time. That is why we keep pushing our research and development efforts further towards both efficiency-enhancing and more eco-friendly measures as well as including important topics of the future, such as digitalised processes in terms of Municipal Technology 4.0.



### We also specialise in cleaning technology

The requirements set on both professional outdoor and contract cleaning are just as comprehensive as is the broad range of solutions we offer our customers: from sweepers and vacuum sweepers to scrubber-driers and combi machines.

Hako GmbH  
Head Office  
Hamburger Str. 209-239  
23843 Bad Oldesloe  
Tel. +49(0)4531-806 0  
[info@hako.com](mailto:info@hako.com)  
[www.hako.com](http://www.hako.com)

**BLUECOMPETENCE**  
Alliance Member

Partner of the Engineering Industry  
Sustainability Initiative

Blue Competence is an initiative of the VDMA ([www.vdma.org](http://www.vdma.org)). By using the trademark "Blue Competence", we commit ourselves to these twelve Sustainability Guidelines of the Mechanical Engineering Industry": [www.bluecompetence.net/about](http://www.bluecompetence.net/about)

In the interest of further technical development we reserve the right to colour-, structural or design modifications. Pictures may show optional equipment. The range of available products and services may vary from country to country.