

HPTO

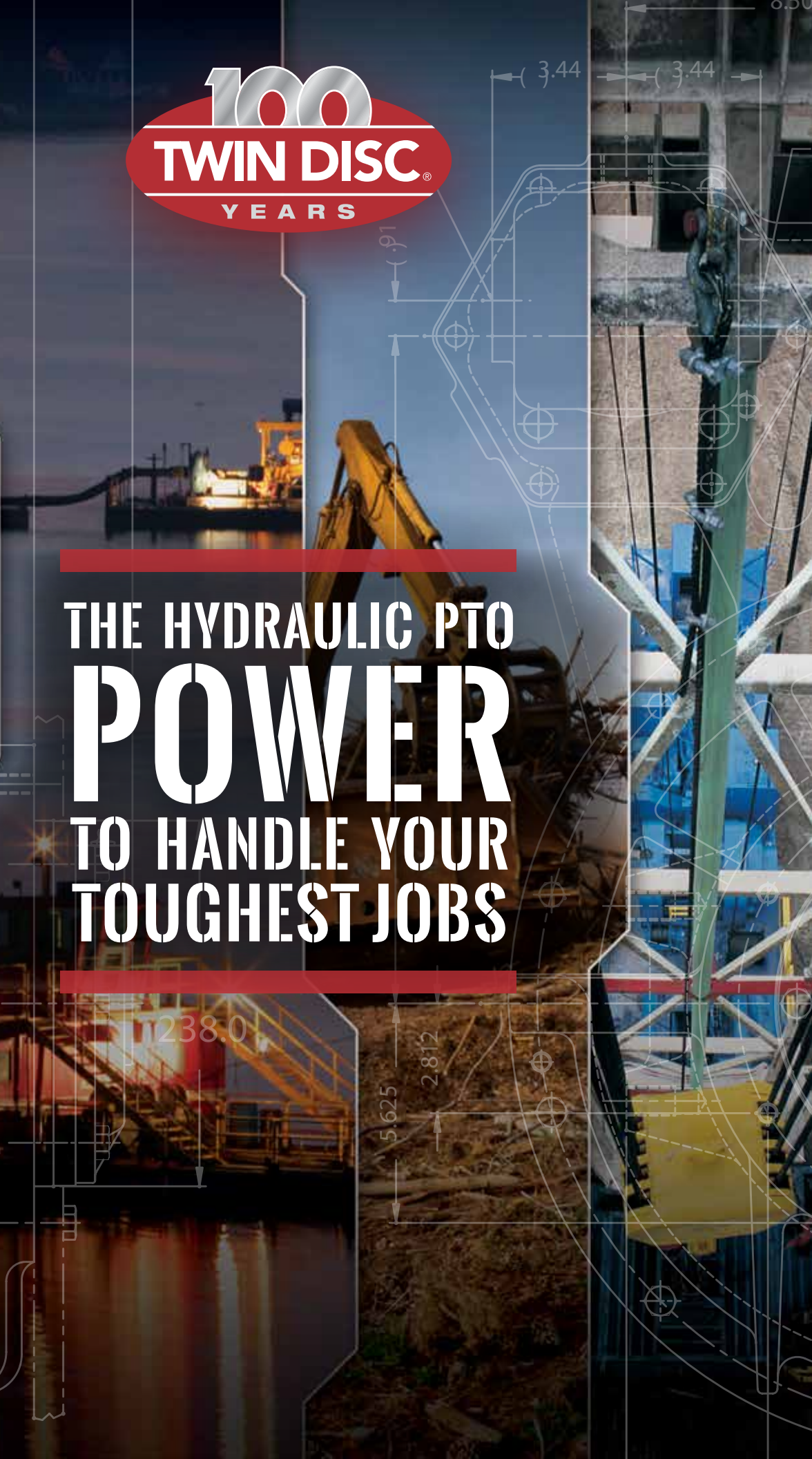

THE HYDRAULIC PTO
POWER
TO HANDLE YOUR
TOUGHEST JOBS



TWIN DISC PUTS HEAVY-DUTY



HP500



HP800



HP1200

With the addition of three new heavy-duty hydraulic PTOs, Twin Disc covers your higher power requirements from 500 hp (373 kW) to 800 hp (597 kW) to 1200 hp (896 kW).

Added to the existing Twin Disc **PFI-60** (275 hp/205 kW) and **PFI-120** (560 hp/420 kW), and you now have broad coverage and Twin Disc renowned quality in rugged-duty, high-horsepower Hydraulic PTOs. The compact but powerful PFI-60 and PFI-120 can mount to an engine, remote mount with shaft input, mount to the input or output of our pump drives, and have a shaft or pump mounting pad as options.



PFI-60 / PFI-120



PRODUCTIVITY IN YOUR RANGE

WHY TWIN DISC HYDRAULIC PTOs?

Hydraulic PTOs are used in heavy-duty applications where you benefit from the torque modulation and cushioning of hydraulic clutches to reduce driveline startup, acceleration, deceleration and shutdown loads. Twin Disc Hydraulic PTOs contain an oil-filled, multiple-disc, hydraulically actuated, self-adjusting clutch.

Typical heavy-duty applications for hydraulic PTOs include crushers, grinders, mulchers, dredgers, pumping, compressors and many more.

In addition to superior driveline equipment protection and performance, Twin Disc Hydraulic PTOs offer the comfort, convenience and safety of remote actuation and control, and flexible mounting options for easier equipment integration.



10 REASONS YOU WANT TWIN DISC



REPUTATION

Twin Disc has a century of inventing, designing and producing an unparalleled and superbly successful array of power transmission products. This new series of HPTOs extends that history of manufacturing excellence. You can stack your reputation on ours.

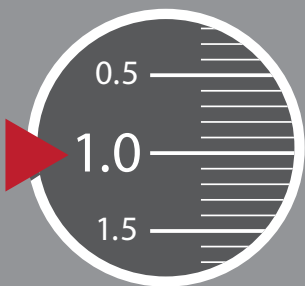

PRECISION MANUFACTURE

From its inception, Twin Disc has always invested in the finest materials, the best machines and top-notch machinists. That's why our products work better and longer and are easier to maintain.



PERFORMANCE

We build every part of our HPTOs with the materials, fit and finish to give you the most cost-effective, durable and productive component in your driveline. We save and earn you more money over the life of your equipment.



RELIABILITY

The inventive engineering, unique features, superior materials, and quality manufacture yield a product that shows up for work on the toughest jobs year after year.

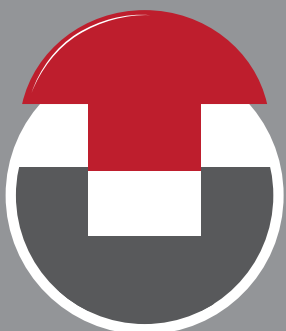

INSTALLATION

Our comprehensive line of heavy-duty HPTOs offers the sizes and output capacities to easily fit and install in almost any machine for your application.

HPTOs IN YOUR MACHINES

MOUNTING OPTIONS

For pumps or other auxiliary equipment, no one offers more convenient mounting options to multiply your productivity.

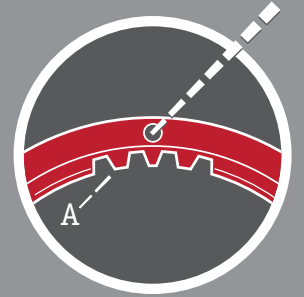

PRECISE CONTROL

Twin Disc electronic controls, in conjunction with the HPTO's inherent driveline protections and safeguards, provide continuous operating metrics so the operator can fine tune your machine's performance and respond instantly to production anomalies.



OPERATOR-CONSIDERATE

Remote control options let your operator remain comfortably in the cab and out of the elements, or, if outside the cab, a prudent distance away from the harsh work and noise of the machine.



EASE OF SERVICE

The easy accessibility afforded by the mechanical brake simplifies and expedites routine servicing of our HPTOs. Should you ever need major service, Twin Disc's broad network of service distributors and dealers will put you back in business fast.



PRODUCTIVITY

At the end of the day, you and your machine are all about getting work done. Twin Disc design and manufacture of this robust family of high-power HPTOs makes rugged-job productivity fast, reliable and easier to accomplish.



BIG FEATURES. HUGE BENEFITS.

HIGH-CAPACITY PUMP TOWER

- HP1200
 - 550 hp (410 kW) total
 - 400 hp (298 kW) per tower
- HP800/500
 - 450 hp (336 kW) total
 - 400 hp (298 kW) per tower
- Overdrive ratios pump towers
 - HP1200 - 1:1 & 0.86:1
 - HP800/HP500 - 1:1, 0.87:1 & 0.77:1
 - Allows for use of smaller displacement hydraulic pumps
- Pump splines can be easily changed on the fly via adapters
- Towers rotatable by 0°/45°/90° cw/ccw
- Integrated charge/lube pump
 - Driven off an idler gear allowing for up to (4) pads to drive auxiliary equipment, such as hydraulic pumps & drivelines
- Available options: dual (4-pad), single (2-pad), and less tower

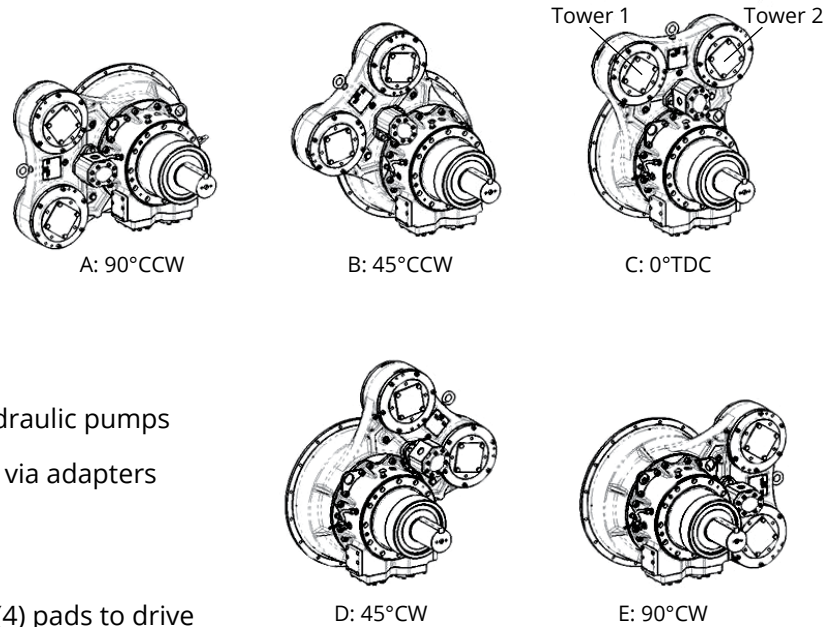

INTEGRATED RESERVOIR (HP1200 & HP800)

- Saves customer from having to remote mount a reservoir and run hydraulic lines to it
- Optional sight glass and level switch along with standard suction strainer

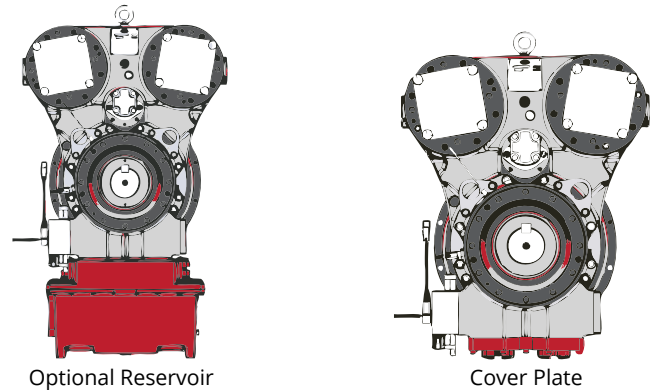

HIGH-CAPACITY BRAKE

- Dynamic multiple-disc wet brake
- Spring Applied, Hydraulically Released (SAHR)
- Quickly slows down high-inertia loads via logic coded into TDEC-050
- Integral mechanical brake release on HP1200 & HP800
- Allows convenient hand release of the output shaft for service without auxiliary power unit

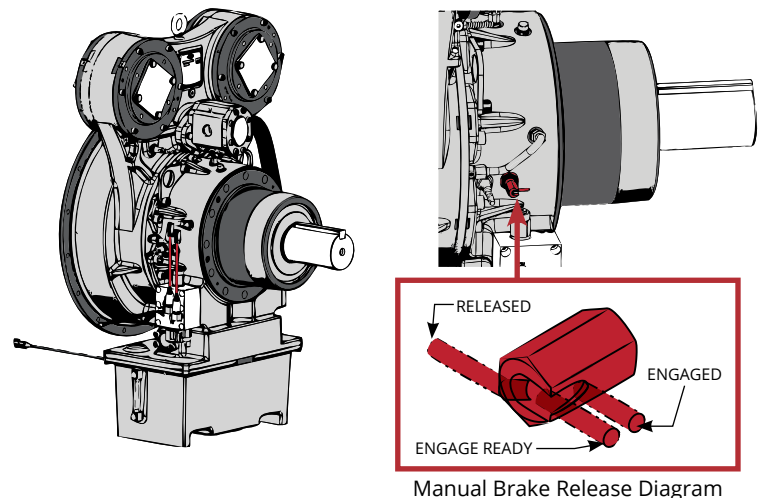

HYDRAULIC POWER TAKE-OFF OPTIONS

AIR/OIL HEAT EXCHANGER

- Brazed aluminum bar & plate construction
- 12/24VDC cooling fan or hydraulic motor fan drive
- Max operating pressure: 350PSI (24BAR)
- Max operating temperature: 250°F (121°C)
- #16 SAE ORB or 1" NPT/BSPP connections
- Integrated filter

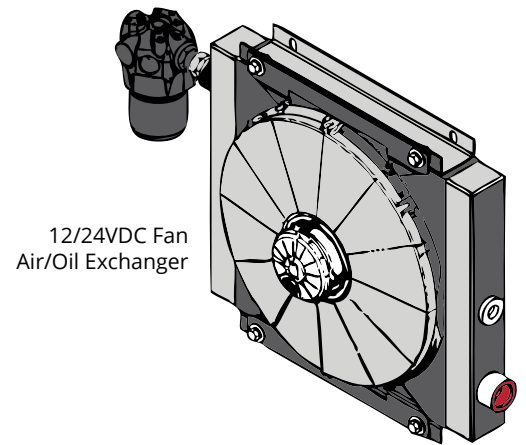

WATER/OIL HEAT EXCHANGER

- Shell & tube construction
- Brass shell/copper cooling tubes
- Max operating shell pressure: 250PSI (17BAR)
- Max operating tube pressure: 150PSI (10BAR)
- Max operating temperature: 350°F (177°C)
- #16 SAE ORB or 1" NPT/BSPP oil connections
- 3/4" NPT or 3/4" BSPP water connections
- Integrated filter

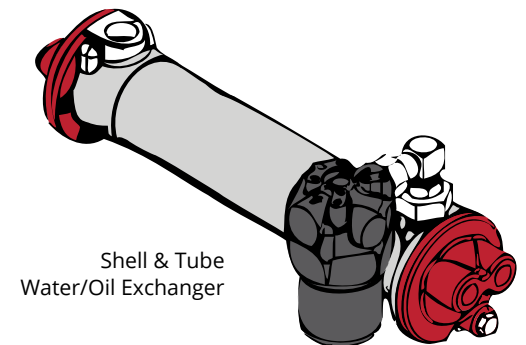

FILTER

- Aluminum head, phosphate steel housing, brass/aluminum bypass
- 230°F (110°C) max temperature
- 51PSI (3.5BAR) opening pressure
- 6 micron absolute/ISO 17/15/12
- #12 SAE ORB connection

HYDRAULIC POWER TAKE-OFF CONTROLS

FEATURES

- Display option for control and/or system monitoring
- Option to wire clutch engagement commands as switch signals or J1939 messages
- J1939 CANbus interface includes operating status messages from the TDEC-050
- Integrated brake control
- LED indicators provide operational status and fault codes, including battery power monitoring
- Warning relay output for fault conditions
- Monitoring of engine speed to protect clutch during engagement process
- Monitoring of engine speed and output speed for controlled engagement process to help ensure precise clutch engagement without overloading the engine or damaging the clutch
- Monitoring of main and clutch oil pressures, temperature and filter (if installed)



SPECIFICATIONS

Operating power: 12VDC or 24VDC nominal • Operating temperature: -40° to 70°C • IP rating: 67

PICK YOUR TWIN DISC HPTO SOLUTION

HP500 500 hp (373 kW)



- SAE #1, SAE #2 & SAE #3 input housings to SAE J617
- SAE 355 (14"), SAE 290 (11.5") & SAE 255 (10") to SAE J620
- Side-load "P" and In-line "I" applications

HP500S & HP500D MODELS		
MAXIMUM POWER RATING	@1200 RPM	333 hp (248 kW)
	@1800 RPM	500 hp (373 kW)
	@2200 RPM	611 hp (456 kW)
MAXIMUM SPEED		2300 RPM
PUMP TOWER CAPACITY	1 Tower (2 Pads)	400 hp (298 kW)
	2 Towers (4 Pads)	450 hp (336 kW)
WEIGHT	HP500S	434 kg (956 lbs)*
	HP500D	536 kg (1181 lbs)*

*Varies with configuration

HP500S

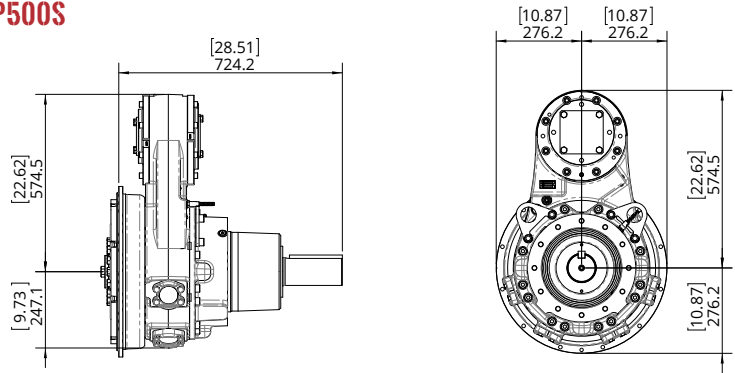

HP500D

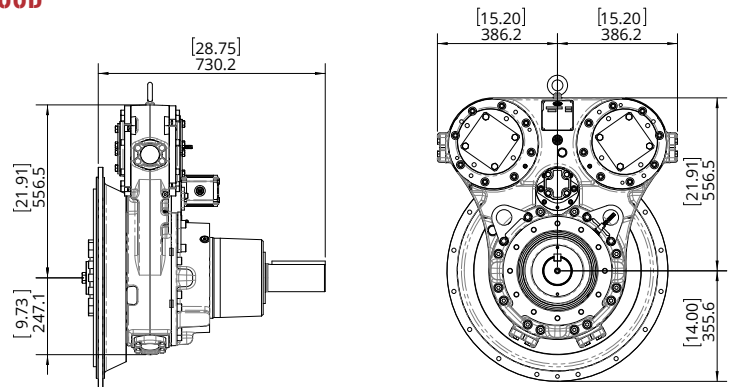

HP500P SIDE LOAD CAPACITY VALUES

RPM	mm	-50.8	-25.4	0	25.4	50.8	76.2	101.6	127	152.4
	inches	-2	-1	0	1	2	3	4	5	6
1200	Lbf.	12,795	11,085	9,789	8,758	7,927	7,238	6,607	5,956	5,423
	N	56,915	49,309	43,545	38,956	35,263	32,197	29,391	26,496	24,123
1800	Lbf.	11,330	9,816	8,668	7,755	7,020	6,409	5,851	5,274	4,802
	N	50,397	43,662	38,558	34,494	31,224	28,509	26,024	23,461	21,360
2100	Lbf.	10,818	9,372	8,276	7,404	6,702	6,119	5,586	5,036	4,585
	N	48,119	41,689	36,816	32,936	29,813	27,221	24,848	22,401	20,395

HP800 800 hp (597 kW)

- SAE #0 & SAE #1 input housings to SAE J617
- SAE 460 (18") & SAE 355 (14") to SAE J620
- Side-load "P" and In-line "I" applications



HP800P & HP800I MODELS		
MAXIMUM POWER RATING	@1200 RPM	533 hp (397 kW)
	@1800 RPM	800 hp (597 kW)
	@2200 RPM	978 hp (729 kW)
MAXIMUM SPEED		2300 RPM
PUMP TOWER CAPACITY	1 Tower (2 Pads)	400 hp (298 kW)
	2 Towers (4 Pads)	450 hp (336 kW)
WEIGHT	HP800P	755 kg (1665 lbs)*
	HP800I	713 kg (1572 lbs)*

*Includes dual tower, optional reservoir and standard charge pump

HP800P

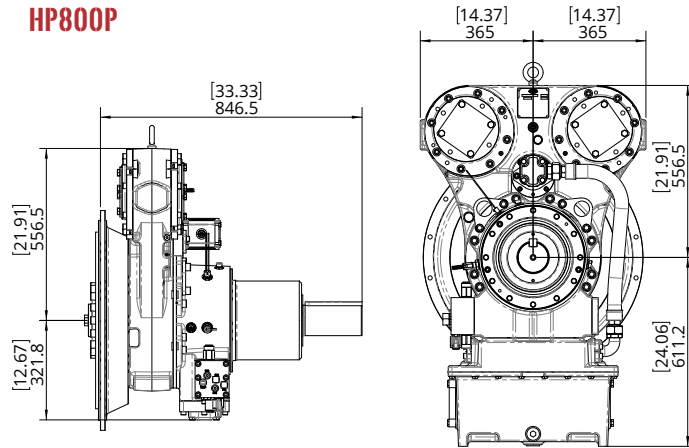

HP800I

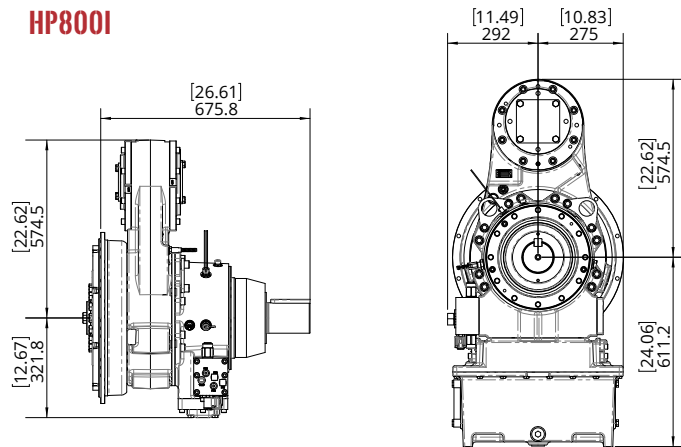

HP800P SIDE LOAD CAPACITY VALUES

RPM	mm	-50.8	-25.4	0	25.4	50.8	76.2	101.6	127	152.4
	inches	-2	-1	0	1	2	3	4	5	6
1200	Lbf.	29,982	27,237	24,953	19,543	15,490	12,718	10,788	9,367	8,276
	N	133,367	121,158	110,996	86,930	68,905	56,575	47,988	41,664	36,814
1800	Lbf.	27,526	25,006	22,909	17,387	13,716	11,262	9,553	8,294	7,328
	N	122,442	111,233	101,903	77,342	61,013	50,095	42,492	36,892	32,597
2100	Lbf.	26,655	24,214	22,183	16,633	13,096	10,753	9,121	7,919	6,997
	N	118,565	107,711	98,676	73,986	58,256	47,831	40,571	35,225	31,124

PICK YOUR TWIN DISC HPTO SOLUTION

HP1200 1200 hp (896 kW)

- SAE #0 & SAE #1 input housings to SAE J617
- SAE 460 (18") & SAE 355 (14") to SAE J620
- Side-load "P" and In-line "I" applications



HP1200P & HP1200I MODELS		
MAXIMUM POWER RATING	@1200 RPM	828 hp (617 kW)
	@1800 RPM	1243 hp (923 kW)
	@2100 RPM	1448 hp (1080 kW)
MAXIMUM SPEED		2250 RPM
PUMP TOWER CAPACITY	1 Tower (2 Pads)	400 hp (298 kW)
	2 Towers (4 Pads)	550 hp (410 kW)
WEIGHT	HP1200P	805 kg (1775 lbs)*
	HP1200I	770 kg (1697 lbs)*

*Includes dual tower, optional reservoir and standard charge pump

HP1200P

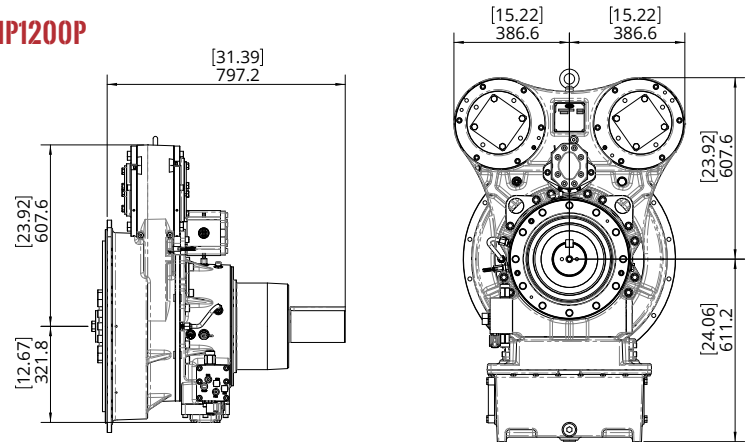

HP1200I

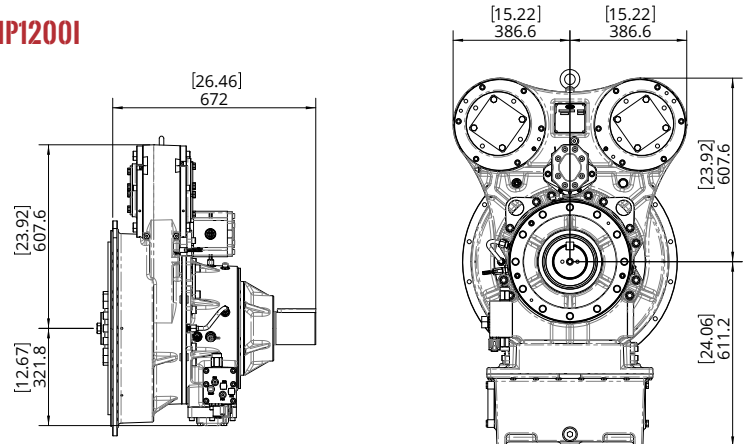

HP1200P SIDE LOAD CAPACITY VALUES

RPM	mm	-50.8	-25.4	0	25.4	50.8	76.2	101.6	127	152.4
	inches	-2	-1	0	1	2	3	4	5	6
1200	Lbf.	32,938	29,654	26,965	24,723	20,660	17,071	14,544	12,669	11,222
	N	146,393	131,794	119,843	109,879	91,821	75,869	64,639	56,305	49,874
1800	Lbf.	29,166	26,257	23,876	21,891	18,294	15,115	12,878	11,218	9,936
	N	129,626	116,699	106,117	97,294	81,305	67,179	57,235	49,856	44,162
2100	Lbf.	27,848	25,071	22,797	20,902	17,467	14,432	12,296	10,711	9,487
	N	123,768	111,425	101,321	92,897	77,630	64,143	54,649	47,603	42,166

PFI-60 & PFI-120

275 hp (205 kW) & 560 hp (420 kW)

ADVANTAGES

- Integral bi-directional gerotor oil pump
- Integral pressure relief valve
- SAE pump mount or keyed shaft output

DESIGNED FOR

- Direct engine mounting or mounted to AM pump drive
- Compact applications

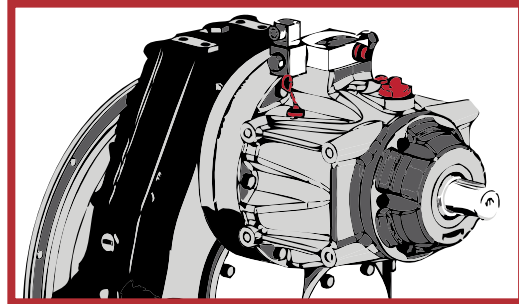

PFI-60

- 275 hp (205 kW) capability
- 12 or 24 Volt DC solenoid
- SAE 3, 2 and 1 input housing configurations
- 1000kg side-load capability
- SAE "A" through SAE "C" pads/splines

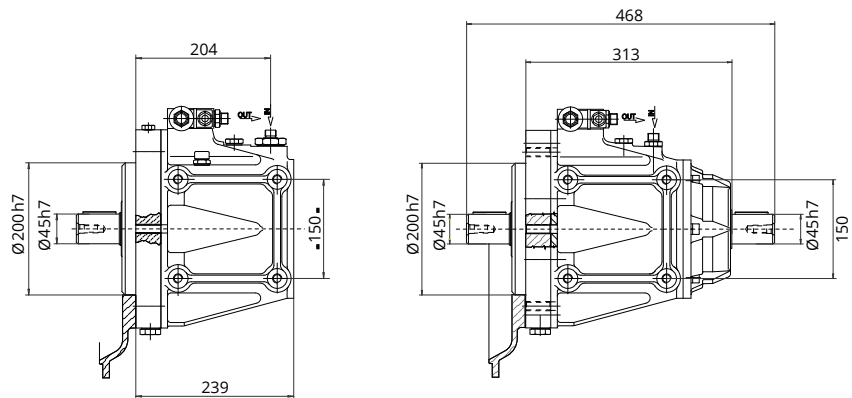

PFI-120

- 560 hp (420 kW) capability
- 12 or 24 Volt DC solenoid
- SAE 3, 2 and 1 input housing configurations
- 1000kg side load capability
- SAE "A" through SAE "C" pads/splines

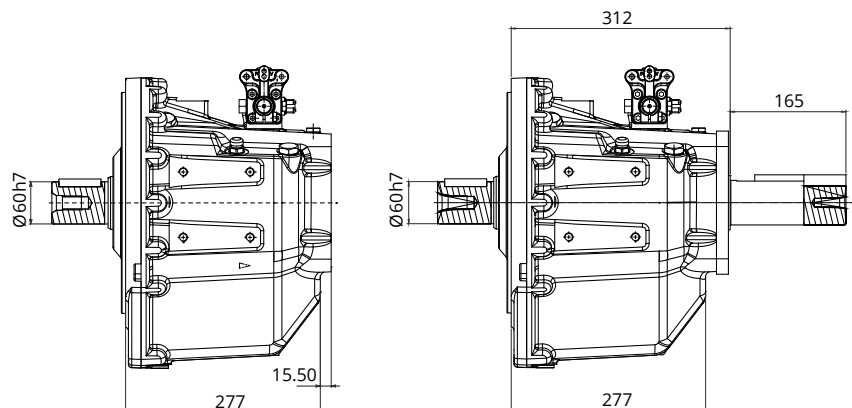



**WE PUT HORSEPOWER
TO WORK®**

100
TWIN DISC®
YEARS

Twin Disc, Incorporated • Racine, Wisconsin 53403, U.S.A. • 262-638-4000 • www.twindisc.com

UNITED STATES OF AMERICA • AUSTRALIA • BELGIUM • CANADA • CHINA • INDIA • ITALY • NETHERLANDS • SINGAPORE • SWITZERLAND

©2018 TWIN DISC, INC • HPTO BROCHURE 04/18