

## TOLCO™ Fig. 75 - Swivel Attachment

**Function:** Three recommended applications for this product:

- May be used as a branch line restraint for structural attachment to anchor bolt, beam clamp, etc.
- May be used as an upper attachment with short hanger rod to omit seismic bracing.
- May be used in a pitched or sloped roof application, to meet requirements of NFPA 13 (2010) 9.1.2.6.

Refer to page 40 for more information and sizing.



## TOLCO™ Fig. 3000 - CPVC Sway Brace Attachment

**Function:** For bracing CPVC and steel pipe against sway and seismic disturbance. The pipe attachment component of a sway brace system: Fig. 3000 is used in conjunction with a Fig. 900 Series fitting and joined together with bracing pipe per NFPA 13, forming a complete sway brace assembly.

Refer to page 41 for more information and sizing.

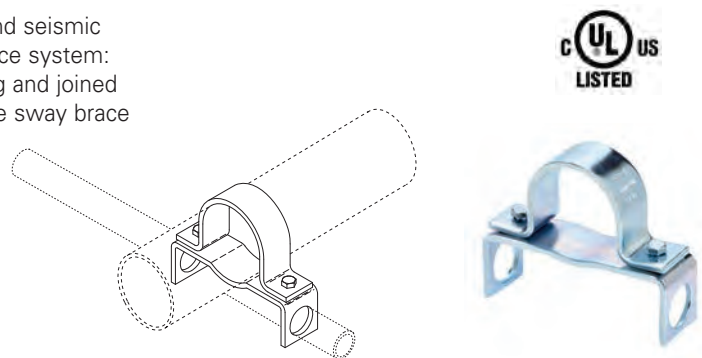

## Fig. 76 - TOLCO™ Structural Attachment for Branch Line Restraint Assembly (UL Listed) Structural Attachment for Sway Brace Assembly (FM)

**Function:** Structural attachment for branch line restraint or sway brace assembly

Refer to pages 42 for UL Listed information and sizing.  
Refer to pages 43 for FM information and sizing.



## Fig. 77 - TOLCO™ Structural Attachment for Branch Line Restraint Assembly (UL Listed) Structural Attachment for Sway Brace Assembly (FM)

**Function:** System attachment for branch line restraint or sway brace assembly

Refer to pages 44 for UL Listed information and sizing.  
Refer to pages 45 for FM information and sizing.



All dimensions in charts and on drawings are in inches. Dimensions shown in parentheses are in millimeters unless otherwise specified.