

TOLCO™ Fig. 906 - Sway Brace Multi-Fastener Adapter

Material: Steel

OPM



Application: Allows sway brace fittings to develop greater load carrying ability by providing multiple fastener attachments for steel and wood. The National Fire Protection (NFPA) provides information on fastener loads to various structures. Refer to NFPA 13 (2016) 9.3.5.9.1.

Approvals: Underwriters Laboratories Listed in the USA (UL) and Canada (cUL) only when used with TOLCO Fig. 900 Series Earthquake Brace Attachments. Included in our Seismic Engineering Guidelines approved by the State of California Office of Statewide Health Planning and Development (OSHPD). For additional load, spacing and placement information relating to OSHPD projects, please refer to our Seismic Engineering Guidelines, OPM-0052-13.

Installation Instructions: Fig. 906 is a multiple fastener structural attachment component of a longitudinal or lateral sway brace assembly. It is intended to be combined with a TOLCO transitional attachment, "bracing pipe" and a TOLCO "braced pipe" attachment to form a complete bracing assembly. NFPA 13 guidelines should be followed.

To Install: Attach the Fig. 906 to the structural surface as per fastener design guidelines. Attach other TOLCO transitional attachment fitting, Fig. 980, 910, 909, or any other TOLCO approved transitional fitting. Transitional fitting attachment can pivot for adjustment to proper brace angle.

Finish: Plain or Electro-Galvanized. Contact customer service for alternative finishes and materials.

Order By: Figure number and specify dimensions H1 and H2.

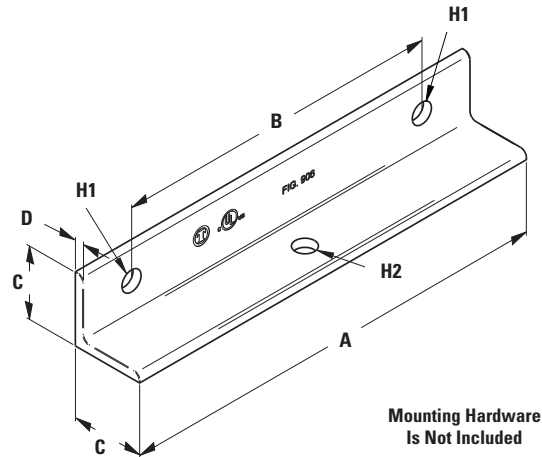

Part Number	A in. (mm)	B in. (mm)	C in. (mm)	D in. (mm)	H1	H2	Approx. Wt./100 Lbs. (kg)
906	12" (305.0)	9" (228.6)	2" (50.8)	1/4" (6.3)	Specify	Specify	307 (139.3)

Load Note: Actual design load determined by anchor and concrete strength, not to exceed the UL Listed maximum horizontal load of 2015 lbs. (8.96kN).
Load is for Fig. 906. If combined load of anchors is less, must reduce to anchor maximum capacity.

Eaton's B-Line series seismic bracing components are designed to be compatible only with other B-Line series bracing components, resulting in a listed seismic bracing assembly. Eaton B-Line Division warranty for seismic bracing components will be the warranty provided in Eaton B-Line Division standard terms and conditions of sale made available by Eaton, except that, in addition to the other exclusions from Eaton B-Line Division warranty, Eaton makes no warranty relating to B-Line series seismic bracing components that are combined with products not provided by Eaton.

All dimensions in charts and on drawings are in inches. Dimensions shown in parentheses are in millimeters unless otherwise specified.