



1. Low Range
2. High Range



Description & Features:

- Designed to measure the differential pressures of liquids and gases between two ports
- Compact, efficient design available in Low or High psi ranges that facilitates installation in tight spaces
- Low Range housing is constructed of stainless steel and aluminum
- High Range housing is made from a 316-grade stainless steel ideally suited for an industrial environment
- Fast response sensor and signal conditioned electronic circuitry provide quick and accurate readings
- Unique isolation system responds to pressure changes approximately 20 times faster than conventional transmitters with ranges below 100 psi (Low Range model)
- CE approval is standard on all models
- NEMA 4 approval is standard on the Low Range model
- 5 year warranty

Applications:

- To measure pressure drops across filters
- Pumps and compressors, flow measurements of gases and liquids, liquid level measurement of pressurized vessels

Specifications	Low Range	High Range
Electrical Output	4-20 mA, 2 wire 0-5 Vdc or 0-10 Vdc	4-20 mA, 2 wire (other options available)
Electrical Connection	Barrier strip terminal block with conduit enclosure and 0.875 dia. conduit opening	DIN 43650 with mate
Excitation Voltage	9-30 Vdc	8-38 Vdc
Wetted Parts / Connection	17-4PH SS with FKM O-ring, 1/4"-18 NPTF	316L SS, 1/4" NPTF 300 series SS, 17-4PH SS with FKM O-ring
Housing	304 SS, cast aluminum	316L SS
Proof Pressure	Refer to pressure range chart on next page	Refer to pressure range chart on next page (20X full scale optional)
Burst Pressure	Refer to pressure range chart on next page	Refer to pressure range chart on next page
Normal Operating Temperature Range	0°F to 175°F (-17°C to 79°C)	-40°F to 200°F (-40°C to 93°C)
Compensated Temperature Range	30°F to 150°F (0°C to 65°C)	0°F to 170°F (-18°C to 76°C)
Ambient Temperature Effect on Zero / Span	±2% of full scale/100°F (37.7°C)	≤ ±1.5% FSO over compensated range
Response Time	30-50 ms	<50 ms
Long Term Stability	±0.5% FSO/yr	≤±0.25% FSO/yr
Weight	14.4 oz. (408 g)	13 oz. (368 g)
Accuracy	±0.25% FSO	±0.25% FSO
Enclosure Rating	IP65	IP65

LTD Low Range					
Uni-directional			Bi-directional		
Gauge psid	Proof Pressure psi	Burst Pressure psi	Gauge psid	Proof Pressure psi	Burst Pressure psi
0/1	2.5	20	0/±0.5	1.25	20
0/2	5	40	0/±1	2.5	40
0/5	12.5	100	0/±2.5	6.25	100
0/10	25	100	0/±5	12.5	100
0/25	62.5	250	0/±10	25	200
0/50	125	250	0/±25	62.5	250
0/100	250	250	0/±50	125	250

LTD High Range		
Gauge psid	Proof Pressure psi	Burst Pressure psi
0/50	100	750
0/100	200	1,000
0/200	500	2,000
0/500	1,000	3,000
0/1,000	2,000	5,000
0/3,000	4,500	7,500
0/5,000	7,500	10,000

Order Codes

Low Range Uni-directional	
Range	Code
0/1 (27.7in/H ₂ O)	LTDU1
0/2 (55.4in/H ₂ O)	LTDU2
0/5 (138.4in/H ₂ O)	LTDU5
0/10 (276.8in/H ₂ O)	LTDU10
0/25 psi	LTDU25
0/50 psi	LTDU50
0/100 psi	LTDU100

Low Range Bi-directional	
Range	Code
±0/0.5 (13in/H ₂ O)	LTDB0.5
±0/1 (27.7in/H ₂ O)	LTDB1
±0/2.5 (69in/H ₂ O)	LTDB2.5
±0/5 (138.4in/H ₂ O)	LTDB5
±0/10 (276.8in/H ₂ O)	LTDB10
±0/25 psi	LTDB25
±0/50 psi	LTDB50

High Range	
Range	Code
0/150 psid	LTD150
0/200 psid	LTD200
0/300 psid	LTD300
0/500 psid	LTD500
0/1,000 psid	LTD1000
0/3,000 psid	LTD3000
0/5,000 psid	LTD5000

Option suffix:

4WCABLE = 4 wire shielded data cable (per ft.)

Other ranges (e.g. bar, etc.) available upon request

Other outputs and options available upon request

Definitions:

- Uni-directional = The instrument is calibrated with a 4 mA output at 0 psid and 20 mA output at full scale (i.e. For 0-10 psid range: 4 mA = 0 psid and 20 mA = 10 psid)
- Bi-directional = The instrument is calibrated with a 12 mA output at 0 psid/zero centre (i.e. For 0-10 psid range: 4 mA = -5 psid, 12 mA = 0 psid and 20 mA = +5 psid)

Low Range

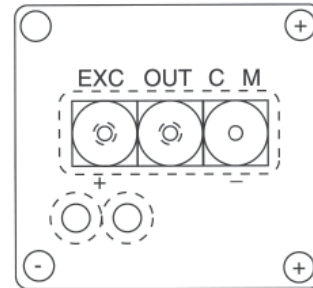
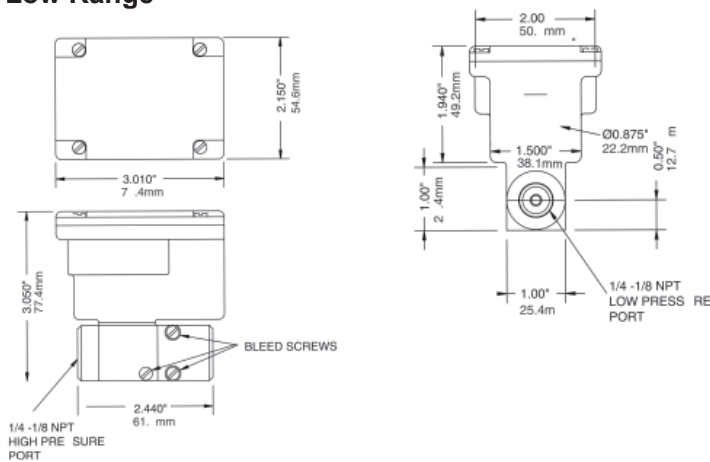

- For voltage output, use COM, OUT and EXC terminals
- For current (4-20 mA) output, use + and - terminals

High Range

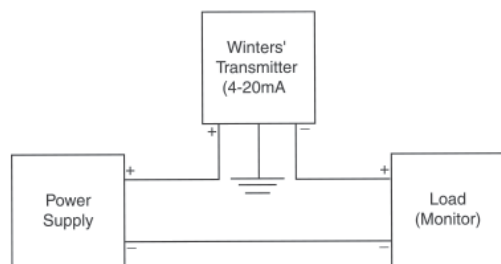
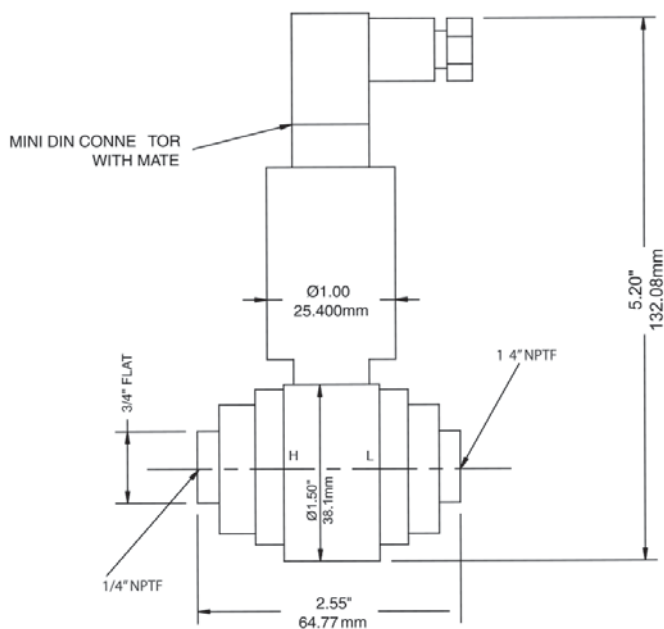

Hirschmann® is a registered trademark of Hirschmann Laborgeräte GmbH & Co.

Hirschmann® Mini-Din Pin Out:

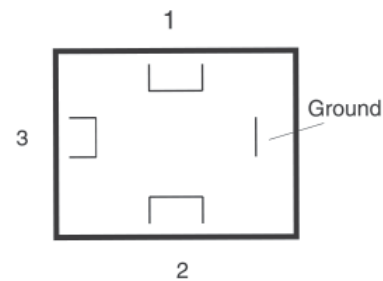

4-20mA output Supply Power: 8-38 Vdc			
Mini-Din Connection			
Pin	Colour Code	V	mA
1	N/A	+Excitation	+Excitation/Signal
2	N/A	-Excitation/Signal	-Excitation/Signal
3	N/A	+ Signal	NC
Grnd	N/A	Gnd	Gnd
Wire Lead Connection			
Wiring	Colour Code	V	mA
1	Red	+Excitation	+Excitation/Signal
1	Black	-Excitation/Signal	-Excitation/Signal
1	Green	+ Signal	NC
Grnd	Shield/White	Gnd	Gnd

Current Output Units

- Low Range (current output) transducers are true 2-wire, 4-20 mA current output devices
- Deliver rated current into any external load of 0-1000 ohms
- 4-20 mA current output units are designed to have current flow in one direction only. Please observe polarity
- An electrical cable shield should be connected to the system's loop circuit ground to improve electrical noise rejection

MIN Supply Voltage: $9 + 0.02 \times (\text{Resistance of receiver plus line})$

MAX Supply Voltage: $30 + 0.004 \times (\text{Resistance of receiver plus line})$