

Valve Actuation: The When, How and Why of Actuator Selection

A guide to actuators for upstream and midstream oil and gas applications



*By Jacqueline Onditi, Earnest Carey,
David Montgomery and Lorenzo Colonna Preti*

Valve automation dramatically improves control, precision and efficiency. While these advantages must be weighed against higher capital and operating costs, actuators are frequently found to be a cost-effective investment for most oil and gas applications.

Once the decision to automate has been made, there is a wide — and often confusing — variety of actuators from which to choose. This paper is designed to make all these decisions easier by providing a quick-reading overview of:

- The key factors to consider when making the decision to automate.
- The most common types of actuators and the applications for which each is best suited. (To aid the reader, major classifications of actuators are organized in the same cascading hierarchy traditionally used for cost/benefit analysis by the oil and gas industry.)
- Hybrid and specialized actuators used for certain specific applications (such as pipeline control).
- Emerging trends in technology and regulation that may influence the decision-making process.



Figure 1: Actuators are frequently found to be a cost-effective investment for most upstream and midstream oil and gas applications.

Is automation right for your application?

Three factors typically encourage the decision to automate:

- **Frequency of operation**—Valves that must perform a high number of operations or regularly perform modulating functions are good candidates for automation.
- **Ease of access**—Automation increases the efficiency of valves in remote areas, unmanned installations, dangerous environments, the execution of lightly serviced processes, and the use of large valves requiring significant time or effort to operate manually.
- **Critical functions**—Actuators offer significant advantages for shutdown or blowdown services, protective applications, applications requiring high precision or speed, reliable performance or process monitoring.

These benefits come with a few tradeoffs. In addition to making systems more complex, actuators directly and indirectly create additional capital and operating costs, including:

- Design and implementation costs
- Physical and logical layout and interfaces
- Process controls (including the integration of automated functions)
- Defining suitable material specifications
- The need for more skilled operating personnel
- Equipment capital and operating cost
- Service utility capital and operating costs
- Actuator maintenance and eventual upgrades



Despite these considerations, the oil and gas industry generally considers the benefits of actuators significant enough to be worth the investment. According to data published by European Industrial Forecasting Ltd. (EIF) in 2015, nearly 75% of all valves in the oil and gas sector are automated, compared to just 30% across all industries combined.

Nearly 75% of all valves in the oil and gas sector are automated, compared to just 30% across all industries combined.

The actuator hierarchy

Each kind of actuator has unique advantages and limitations. While no single type is appropriate for every job, it's relatively easy to determine which category is the best fit for your application.

The industry typically compares the three major options using a cascading hierarchy: electric actuators are usually the first choice whenever possible, followed by pneumatics and hydraulics, in that order.

Figure 2: Automation increases the efficiency of the valves in remote areas, unmanned installations and dangerous environments.

Electric actuation

Electric actuators use electrical power to actuate a valve. While most of the basic technology used in electric actuators has been around since the 1930s, decades of incremental improvement have significantly increased their functionality while dramatically reducing their cost. In recent years, these advances have reached a tipping point that makes electric actuators the first choice for a wide variety of applications.

Pros

- Electric power is relatively inexpensive, easy to manage, and normally available to most industrial sites. The capital cost of electric actuators is typically cheaper per equivalent unit of torque/thrust output. They're also cleaner and safer to operate.
- Electric actuators can provide superior positioning accuracy for control or modulating valve functions, which can include provisions for a high degree of process monitoring, data logging and information feedback.
- All necessary control functions are integral to electric actuators, reducing capital costs.
- Electric actuators significantly reduce control wiring costs by enabling distributed control. They simplify control logic by integrating control commands and feedback into customer SCADA or DCS systems. (Traditional electromechanical control systems require a dedicated wire for each command and feedback signal, leading to cable bundles with seven or more cores as minimum for each actuator. By contrast, a typical bus system can use one twisted pair wire in a daisy chain configuration to carry all required input and output signals.)

- As torque and thrust requirements increase, electric actuators weigh less and have smaller footprints compared to pneumatic actuators.
- Electric actuators may be combined with external gearboxes to produce extremely high output thrust and torque values.

Cons

- With the exception of a few specific configurations, electric actuators can't guarantee a fail-safe stroke but will "fail in the last position." (Fail-safe stroke refers to an actuator's ability to move a valve to a predefined safe position when power fails).
- Electric actuators have more complex and sensitive components than the mechanical parts used in other types of actuators. Electronic technology also requires periodic refreshing to keep pace with component changes and improvements.
- Beyond a certain size/torque range, electric actuators are less cost-effective and generally have limitations in operating speed when compared to pneumatic and hydraulic actuators.
- In hazardous areas with potential exposure to explosive process media, electric actuators require more specific certifications and construction features to be considered safe for use.

Recommended applications

Electric actuation is the first choice for most oil and gas applications. They're ideal for general process valve automation, non-critical applications, and light-duty modulating applications (generally up to 1200 starts per hour), although some can modulate continuously up to 3600 starts per hour.

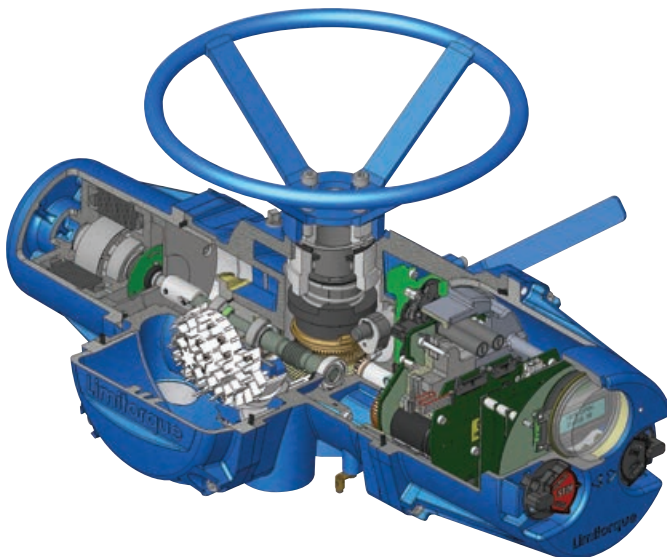

Figure 3: In recent years, electric actuators have become the first choice for a wide variety of applications because of their versatility, superior positioning accuracy and low cost of ownership.

Pneumatic actuation

Pneumatic actuators are simple mechanical devices, able to incorporate a mechanical action or valve stroke by storing energy in a spring.

A key advantage of this design is that a pneumatic actuator can always reach a predefined safe condition, even after the loss of its primary power supply (compressed air or electricity to the control components). This is the most important differentiator between pneumatic and electric actuators today. It's also why nearly 90% of on/off piston-type actuators are spring-return (as opposed to double-acting).

Pneumatics become the actuator of choice in applications where electric actuators don't meet process requirements for fail-safe action, high torques or very high operating speed.

Pros

- Pneumatic systems run on compressed air, a safe fluid medium (electric power is necessary to operate a compressor).
- Pneumatic control equipment is widely available and relatively inexpensive.
- Pneumatic control systems can be configured to achieve a vast range of functions. Heavy-duty pneumatic actuators can be used for modulating applications (though not with a high degree of positioning accuracy or hysteresis).
- Pneumatic actuators allow very high-speed operation.

Figure 4: Because of their ability to store energy in a spring, pneumatic actuators can always reach a predefined safe condition (fail-open or fail-closed), even after the loss of its primary power supply.

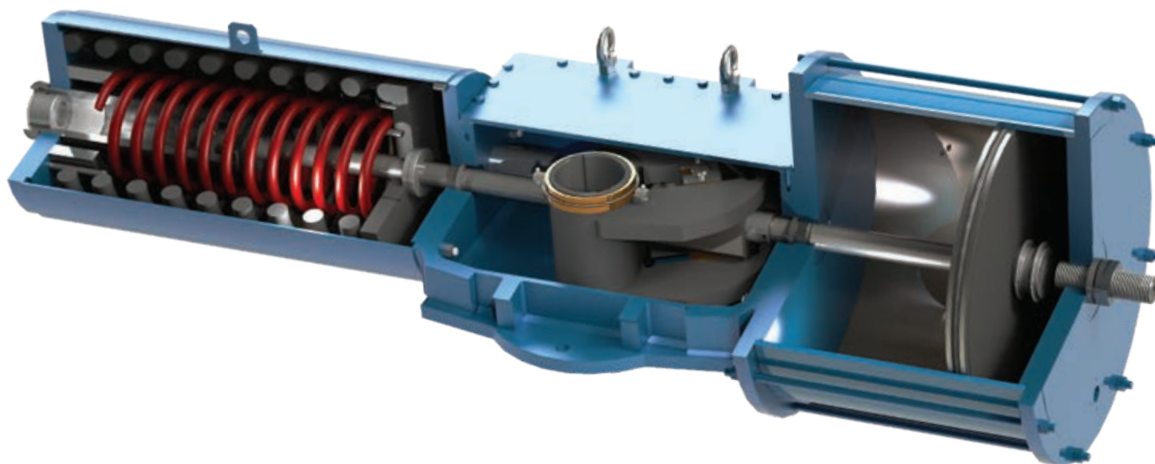

Cons

- Pneumatic actuators are typically more costly than equivalent torque electric actuators on all but the largest valves, especially when factoring in control components such as solenoid valves, air filter regulators and other pneumatic instrumentation.
- At present, pneumatic actuators are not easily integrated into electronic data management systems.
- As valve size increases, pneumatic actuator size also increases. Pneumatic cylinders can become large with very high air volumes, leading to more energy costs for compressed air, large footprints, and high weight impacting on piping construction support. This may be a concern for upstream offshore applications, where size and weight compactness is often an important requirement.
- The regulatory environment for pneumatics is changing much faster than the actuators themselves. Proven existing systems increasingly require approval from third-party validating agencies, while safety and integrity compliance standards are regularly increased. As a result, pneumatic systems can require periodic upgrades to meet new standards of materials usage and performance guarantees.

Recommended applications

Pneumatic actuators are widely used in onshore oil and gas applications. They also account for about 40% of offshore applications, typically on small- to medium-sized valves where their size and weight penalties have less impact on construction costs and installation footprints.

Hydraulic actuation

When size and weight requirements no longer make pneumatic actuators economical, the choice shifts to hydraulic actuators. Other specific factors can also drive the choice to hydraulics, usually as a result of the specific characteristics of hydraulic fluids.

Pros

- While hydraulic cylinders must be stronger and thicker to contain higher pressures, they have much smaller dimensions. This size benefit is the primary reason to use hydraulic actuation.
- Unlike pneumatics, the high-pressure mineral oil that drives hydraulic actuators can't be compressed. For this reason, hydraulic actuators are more precise than pneumatics, making them preferred for use in modulating or positioning applications where a high degree of accuracy is required.
- In corrosive atmospheres, hydraulic fluids offer a higher degree of corrosion protection in the actuator cylinder than air or gas.
- Hydraulic systems can operate very large actuators at extremely high speeds.

Cons

- High-pressure hydraulic fluid is complex to manage, creating safety and environmental risks. Personnel with higher skill levels are required when dealing with high-pressure hydraulic instrumentation.
- Hydraulic control instrumentation is significantly more expensive, and is available from a much smaller supplier base.
- Like pneumatics, hydraulic actuators face increasingly stringent regulation. The mineral oil used in hydraulic systems adds an additional set of environmental limitations relating to handling, disposal, pollution risks and other factors.

Recommended applications

Offshore installations and upstream applications are the primary users of hydraulic actuators. In these environments, the space- and weight-saving benefits of the small cylinders are significant enough to offset the higher costs and risks associated with the use of high-pressure hydraulic fluids.

Onshore applications will primarily require hydraulic actuation only when extremely high torques or operating speeds are required by a specific application.

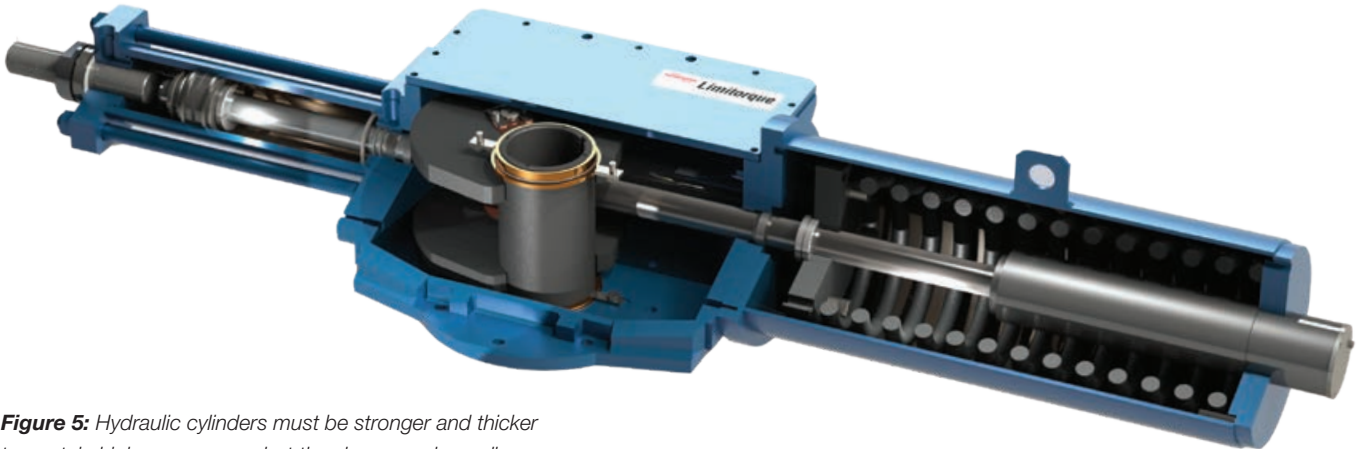

Figure 5: Hydraulic cylinders must be stronger and thicker to contain higher pressures, but they have much smaller dimensions. This size benefit is the primary reason to use hydraulic actuation.

Specialized actuators for pipeline applications

Two major types of actuators lie outside the hierarchy detailed on page 3: gas-powered and electrohydraulic. Depending on the application, one of these might replace a counterpart in any of the three major categories. Both are primarily used by the midstream segment, most specifically by the pipeline industry.

The defining characteristic of pipeline actuation is the need to automate large isolating ball valves, typically used to seal off segments of pipeline for routine process isolation, line break mitigation, pigging, and so on. Pipeline applications also tend to be remote from other industrial infrastructure. This often means no external power supply is available, or that electric power (the easiest form to transmit) is the only option.

The automation products that best serve these specialized needs are gas-powered actuators, in which the motive fluid power is the pipeline product itself, or in certain circumstances, electro-hydraulic actuators.

Gas-powered actuators

There are two types of gas-powered actuators:

- **Direct gas** — In this configuration, pipeline gas is piped directly into the actuator power cylinder.
- **Gas-over-oil** — This design pumps pipeline gas into a tank used to pressurize hydraulic fluid, which is subsequently piped to the actuator power cylinder.



Figure 6: Because of their remote locations and distance from infrastructure utilities, pipeline applications often rely on gas-powered actuators to automate large isolating ball valves.

Pros

- Gas-powered actuators require no external power supply. Motive power is provided by the pipeline product and is always available for use.
- Pipeline pressure can support the use of large actuators in any environment, allowing isolation or fail-safe action either through a mechanical spring (in direct gas versions) or through stored hydraulic pressure (in gas-over-oil models).

Cons

- The primary drawback of gas-powered actuators is tied to their main advantage. Using the pipeline product results in a relative “waste” of the product.
- More importantly, every stroke of the valve exhausts pipeline gas into the atmosphere with negative environmental effects. In these cases, an efficient torque mechanism and a smaller cylinder volume per unit of torque are important to reduce the amount of exhaust gas.

Comparative advantages

- Direct gas actuators weigh less than gas-over-oil models and have lower initial capital cost because they require no tanks or hydraulic controls. They also have simpler control circuitry because they operate only on the gas supply.
- Gas-over-oil actuators have the advantage of using clean hydraulic fluid in the actuator power cylinder. This is especially significant in case of line gases with heavy particulate or corrosive contents.

Despite the longevity benefits of gas-over-oil, markets that use gas-powered actuators are moving toward direct gas because of improved anti-corrosion treatments (such as high-thickness electroless nickel plating and improved filter elements) that allow direct use of dirty or corrosive gases with reduced impact on power cylinder efficiency and integrity.

In markets such as the United Kingdom, environmental concerns are gradually leading to the replacement of gas-powered actuators with electrohydraulic models.

Electrohydraulic (EH) actuators

In its basic form, an electrohydraulic (EH) actuator combines an electric motor and pump assembly to pressurize a reserve of hydraulic fluid, a hydraulic control group to handle open/close functionality, and a hydraulic actuator to operate the valve. This basic design can be expanded to include a wide range of electrical or electronic control components, allowing command and feedback capabilities equivalent to those of electric actuators.

Pros

- EH actuators combine the infrastructure simplicity of electric power with the advantages of piston-type actuators, including mechanical fail-safe action, high operating speeds and high operating torques. They also offer key advantages of hydraulic actuators, such as reduced footprints when automating very large valves and high precision modulating and positioning capability.
- Electrohydraulic actuators are already in widespread use in the power sector and are becoming more popular for oil and gas applications, primarily in the mid- and downstream segments or onshore upstream.
- In the other segments, electrohydraulics are becoming increasingly popular for retrofitting applications. EH offers a viable alternative to manual valves where industrial power supplies are readily available but where air or oil compressor units and relevant distribution infrastructure would create intrusive designs or capital cost barriers.
- On small and medium valves in remote locations, improving solar panel technologies are making solar-powered electrohydraulics a viable option. Australia is leading the way on coal seam gas applications.
- Western Europe is leading the gradual conversion of pipeline actuators from gas powered to electrohydraulic for environmental reasons. In many cases however, the electric power supply to EH is industrial rather than solar, both for climatic and power draw reasons. This is possible because of smaller pipeline networks (both in terms of length and diameter), mature and distributed supporting infrastructure across the territories impacted, and the higher social value given to environmental factors that drive political and regulatory decisions in the direction of “green” solutions, even at overall higher costs.

Cons

- The primary drawback to EH is the higher capital and operating costs, resulting from the complexity of the systems and the risks associated with high-pressure hydraulic fluid (as in the case of standard hydraulics).
- Low-pressure EH models are available, but are only viable on smaller valves (up to approximately 12–16 in, depending on the valve pressure rating). For this reason, adoption rates are lower in the oil and gas industry (where larger valves are frequently necessary) than in the power industry (which typically utilizes smaller valves).

EH actuators combine the infrastructure simplicity of electric power with the advantages of piston-type actuators, including mechanical fail-safe action, high operating speeds and high operating torques.

- Extensive use of standard hydraulics makes the business case for EH less compelling in upstream offshore oil and gas applications, where it's more convenient to centralize the hydraulic power unit for supply to several standard hydraulic actuators than to provide each actuator with a dedicated onboard motor/pump/oil reserve assembly.

Future developments

Heavy-duty piston actuators

There is growing industry demand for mechanical workhorses designed specifically to operate valves, typically with expected lifespans of 20 to 40 years.

The goal is to improve mechanical efficiency, reliability and safety. Some initial progress is being made toward integrating piston actuator control components into plant SCADA or DCS systems. Most of these developments are being carried out by control equipment providers, both independently and as part of automation groups.

More widespread use of electrohydraulic actuators

EH trends on the horizon include: higher modularity and flexibility of configurations and features compared to previous “closed box” standards. Higher data collection, storage and integration capabilities are also in the works. Most intriguing is a trend toward purely electric fail-safe actuators, which would offer the benefits of current electrohydraulic systems without the downsides of high-pressure oil.

Electric fail-safe functions seem to be developing in two separate directions:

1. Including a mechanical element: A spring, coupled to the motor drive train during normal operation, but disengaged and free to intervene in the fail-safe scenarios.
2. Using supercapacitors to allow a reserve of electrical energy to power the fail-safe action when required.



As usual, there's no single perfect solution. Where application of IEC 61508 is required, spring-return mechanisms enable an SC3 SIL3-compatible rating on the safety function where required, but are larger, heavier and more costly. Supercapacitor solutions can't be rated higher than SC2 without physical redundancy, but are smaller, lighter and less expensive. Both technologies still have limitations in terms of the size of valves that can be actuated, which currently limits their use in many oil and gas scenarios.

New materials and sealing technologies

While most of today's actuators use traditional materials like steel and iron, manufacturers are considering the benefits of using composite materials for construction of pressure-retaining parts and other components. As material properties keep improving, it will be possible to achieve considerable weight savings and improve corrosion resistance. Both of these benefits would have significant impacts on offshore installations, to name just one example.

New materials and sealing technologies could also help reduce metal-to-metal contact on actuator moving parts, an essential step toward improving the performance reliability of long stand-still actuators.

Another exciting material application that could provide direct operating cost benefits is the use of ceramics on Scotch yokes, particularly in high-cycle applications. The performance gains could be impressive, not to mention the improved lifespan and process uptime.

Figure 7: Actuator manufacturers are exploring the benefits of advanced composite materials, like those used in the manufacture of wind turbine blades. Composites can offer considerable weight savings and excellent corrosion resistance without sacrificing strength or durability.

Future developments *(continued)*

Integrated operations and “smart” valves

Sensor technology keeps getting cheaper, as does data processing capability. By combining the two, valves and actuators can be integrated with sensors that monitor operating pressures, torque and speed output, and wear of critical parts — all in real time. This potent combination enables more and better predictive maintenance, driving increased safety and efficiency.

This fits in well with the increasingly popular trend of integrated operations, commonly known as IO, which relies heavily on real-time information gathering and transmission. Process operators need to achieve more with less, so remote

operations and unmanned facilities run from a centralized control room are a growing trend. Self-diagnosing electric actuators that communicate with remote control systems are already common, so it's not a big stretch to extend the same capabilities to fluid-powered models.

In addition, wireless communication is increasingly being used to transfer process information. All this can be built into automation packages covering the final control element: the actuated valve as an intelligent, self-monitoring, vertically integrated assembly.

Flowserve can help

Not sure which actuator solution is right for your application? We can help.

Flowserve actuators are available in electric, pneumatic, hydraulic and electrohydraulic designs. Numerous options and upgrades are also available to address a wide variety of process, networking and operational needs. We understand that you have many factors to consider, and that selecting the right actuator for your application can be confusing. Actuation experts are available to advise you on your application requirements.

We encourage you to contact your local Flowserve sales representative to learn more. Contact details can be found at **Flowserve.com**.

About the authors

Jacqueline Onditi —

Specialist Product Manager, Heavy-duty Actuators

Jacqueline Onditi is a product manager of heavy-duty actuators for Flowserve Limatorque. From an accounting background, she started her career in an administrative role with a global actuator manufacturer in 1997, but an aptitude for technical issues and customer relationships quickly led her to transition into account management, and later to automation project management. Her background includes working closely with EPCs and end-user companies to develop automation solutions on key oil & gas projects across the Middle East, Asia and the Americas.

Earnest Carey —

Principal Limatorque Portfolio Manager

Earnest (Earnie) Carey, Jr. has been with Flowserve Limatorque for more than 35 years, serving as principal portfolio manager since 2010. Earnie started his tenure in the 1980s as a test engineer involved with environmental qualifications of safety-related electric actuators. He moved to product development in the early 1990s and has been the product manager of the Flowserve MX and QX non-intrusive actuator product lines since 1998. Earnie is an active member of the VMA and BVAA, and has presented technical papers atACHEMA.

David Montgomery —

Senior Product Manager

Dave Montgomery is a senior product manager for electric actuation products. Over his 39-year tenure with Limatorque and Flowserve Corporation, he helped develop project management software and has worked as a senior applications engineer and inside sales manager for water industry sales. He has managed the Flowserve intrusive design of SMB and L120 electric actuators, and four gearbox lines for 16 years. He served for 10 years as chair of the American Water Works Association subcommittee on the revision of the ANSI/AWWA C542 standard for Electric Motor Actuators for Valves and Slide Gates.

Lorenzo Colonna Preti —

Automation Global Technical Specialist

Lorenzo Colonna Preti joined Flowserve in 2014, bringing extensive experience with the fluid power actuation market in the oil & gas industry. Prior to Flowserve he held management roles in sales and marketing of actuators and valve OEMs, being globally responsible for topside and subsea actuation as well as complete instrumentation packages for HIPPS and special applications. More recently he served as product manager of the Limatorque Fluid Power actuators portfolio, where he was instrumental in its growth and market share expansion. Lorenzo's education includes an MBA and a degree in aerospace engineering.

Flowserve Corporation
5215 North O'Connor Blvd.
Suite 2300
Irving, Texas 75039-5421 USA
Telephone: +1 937 890 5839

Flowserve Corporation has established industry leadership in the design and manufacture of its products. When properly selected, this Flowserve product is designed to perform its intended function safely during its useful life. However, the purchaser or user of Flowserve products should be aware that Flowserve products might be used in numerous applications under a wide variety of industrial service conditions. Although Flowserve can provide general guidelines, it cannot provide specific data and warnings for all possible applications. The purchaser/user must therefore assume the ultimate responsibility for the proper sizing and selection, installation, operation, and maintenance of Flowserve products. The purchaser/user should read and understand the Installation Instructions included with the product, and train its employees and contractors in the safe use of Flowserve products in connection with the specific application.

While the information and specifications contained in this literature are believed to be accurate, they are supplied for informative purposes only and should not be considered certified or as a guarantee of satisfactory results by reliance thereon. Nothing contained herein is to be construed as a warranty or guarantee, express or implied, regarding any matter with respect to this product. Because Flowserve is continually improving and upgrading its product design, the specifications, dimensions and information contained herein are subject to change without notice. Should any question arise concerning these provisions, the purchaser/user should contact Flowserve Corporation at any one of its worldwide operations or offices.

©2018 Flowserve Corporation. All rights reserved. This document contains registered and unregistered trademarks of Flowserve Corporation. Other company, product, or service names may be trademarks or service marks of their respective companies.

FLS-VA-EWP-00005-EN-EX-US-0518 (E) May 2018