



Optional Case

Description & Features:

- Highly accurate $\pm 0.5\%$ complete with calibration certificate traceable to NIST standards
- Mirrored anti-parallax dial
- Knife-edge pointer
- Protective carrying and storage case available
- ASME B40.100 compliant
- CRN registered
- 5 year warranty

Applications:

- Designed to be used where accuracy and repeatability are of prime importance
- Used in laboratories and instrument testing facilities

Specifications

Dial	White aluminum with black markings and mirror band for precise instrument readings
Case	AISI 304 SS
Lens	4" (100mm): Polycarbonate 6" (150mm): Glass
Ring	AISI 304 SS
Socket	Brass
Connection	1/4" NPT or 1/2" NPT standard, bottom
Bourdon Tube	Phosphor bronze
Movement	Brass
Pointer	Aluminum, anodized black, micrometer adjustable, knife-edge
Welding	Silver alloy
Over-pressure Limit	30% of full scale value
Working Pressure	Maximum 75% of full scale value
Calibration Conditions	68°F ($\pm 5.4^\circ\text{F}$), 20°C ($\pm 3^\circ\text{C}$) for ambient and process temperatures at atmospheric pressure
Ambient/Process Temperature	-4°F to 150°F (-20°C to 65°C)
Accuracy	$\pm 0.5\%$ ANSI/ASME Grade 2A
Enclosure Rating	IP65
Warning (brass internals only)	 WARNING: This product can expose you to chemicals including lead, which is known to the State of California to cause cancer and birth defects or other reproductive harm. For more information go to www.P65Warnings.ca.gov .

Order Codes

Dial Size	4" (100mm)		6" (150mm)	
Connection	1/4" Bottom	1/2" Bottom	1/4" Bottom	1/2" Bottom
30" Hg Vac	PTG3999	-	PTG6999	PTG6055
0/15 psi	PTG4000	-	PTG6000	PTG6056
0/30 psi	PTG4001	-	PTG6001	PTG6057
0/60 psi	PTG4002	-	PTG6002	PTG6058
0/100 psi	PTG4003	-	PTG6003	PTG6059
0/160 psi	PTG4004	-	PTG6004	PTG6060
0/200 psi	PTG4005	-	PTG6005	PTG6061
0/300 psi	PTG4006	-	PTG6006	PTG6062
0/400 psi	PTG4007	-	PTG6007	PTG6063
0/600 psi	PTG4008	-	PTG6008	PTG6064
0/1,000 psi	-	PTG4009	PTG6016	PTG6009
0/1,500 psi	-	PTG4010	PTG6017	PTG6010
0/2,000 psi	-	PTG4011	PTG6018	PTG6011
0/3,000 psi	-	PTG4012	PTG6019	PTG6012
0/5,000 psi	-	PTG4013	PTG6053	PTG6013
0/10,000 psi	-	PTG4014	PTG6054	PTG6014

Other ranges and connection sizes available upon request. For scale change, refer to How to Order Guide for scale codes.

For options, attach suffix to end of order code: i.e. PTG2006-6BF for BACK FLANGE

Option suffix:

4BF = 4" (100mm) Back flange
 4FF = 4" (100mm) Front flange
 6BF = 6" (150mm) Back flange
 6FF = 6" (150mm) Front flange

6FF = 6" (150mm) Front flange
 TG4 = 4" (100mm) Test gauge case
 TG6 = 6" (150mm) Test gauge case

4" Bottom Connection with Back Flange

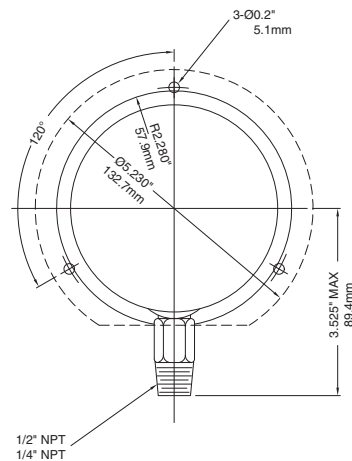

6" Bottom Connection

