



YT-3700



YT-3750

Contents

1	Introduction	5
1.1	General Information for the users	5
1.2	Manufacturer Warranty	5
1.3	Explosion Proof Warning (Only for Intrinsic safety type positioners).....	6
2	Product Description	7
2.1	General	7
2.2	Main Features and Functions	7
2.3	Label Description	8
2.4	Product Code	13
2.5	Product Specification	14
2.6	Specification of Digital In, Digital out	15
2.7	Certifications	16
2.8	Parts and Assembly	18
2.9	Product Dimension	20
2.9.1	YT-3700	20
2.9.2	YT-3750	20
3	Installation	21
3.1	Safety	21
3.2	Tools for installation	21
3.3	Linear positioner Installation	22
3.3.1	Linear positioner Installation of Standard lever type.....	22
3.3.2	Safety.....	22
3.3.3	Standard lever type positioner Installation Steps	23
3.4	Rotary positioner Installation	26
3.4.1	Components.....	26
3.4.2	Rotary Bracket Information	27
3.4.3	Rotary positioner Installation Steps	28
4	Connection - Air	29
4.1	Safety	29
4.2	Supply Pressure Condition	29
4.3	Piping Condition.....	29
4.4	Connection – Piping with actuator	30
4.4.1	Single acting actuator	30
4.4.2	Double acting actuator	30
5	Connection – Power	31
5.1	Safety	31
5.2	Connection.....	32
5.2.1	Standard Terminals	32
5.2.2	Terminals with micro-limit switch option	34

5.2.3	Terminals with proximity Limit Switch option	35
5.3	Ground	35
6	Adjustments	36
6.1	Limit Switch Adjustment.....	36
6.2	A/M switch adjustment.....	37
6.3	Orifice Installment.....	38
6.3.1	Plate type Orifice Installment.....	38
7	Optional Sub-PCB Installment.....	39
7.1	Installation steps	39
8	Auto Calibration and PCB Operation.....	41
8.1	Warning.....	41
8.2	LCD display and buttons.....	41
8.2.1	LCD display and symbols	41
8.2.2	Button and function	42
8.3	Menu levels.....	43
8.4	RUN Mode Monitor	44
8.5	Configuration and Operation.....	45
8.6	Calibration (CALib)	49
8.6.1	Acting Type (SINGLE / dDOUBLE).....	49
8.6.2	Auto Calibration 1 (AUTO 1).....	50
8.6.3	Auto Calibration 2 (AUTO 2).....	50
8.6.4	Travel Zero (TVL ZERO) and Travel end (TVL ENd)	51
8.7	Manual Operation (MAN OPER).....	52
8.7.1	Manual Operation by Set position (MAN SP)	52
8.7.2	Manual Operation by MV (MAN MV)	53
8.8	Control Parameters (CTL PARM)	54
8.8.1	Dead Band (dEAdbANd).....	54
8.8.2	Forward P parameter (KP UP) and reverse P parameter (KP dN).....	55
8.8.3	Forward Integral time parameter (TI UP) and reverse Integral time parameter (TI dN).....	55
8.8.4	Forward D parameter (Kd UP) and reverse D parameter (Kd dN)	56
8.8.5	Auto Dead band Mode (AUTO db)	56
8.8.6	Performance Mode (PER)	57
8.9	Input Configuration (IN CFG).....	58
8.9.1	Signal Direction (SIG NORM / REVS)	58
8.9.2	Split Range Mode (SPLIT).....	59
8.9.3	Custom Split Range Zero (CST ZERO).....	59
8.9.4	Custom Split Range End (CST ENd).....	60
8.9.5	Valve Flow Characterization Curves (CHAR)	60
8.9.6	User Set Characterization 5 Points (U5)	61
8.9.7	User Set Characterization 21 Points (U21)	62

8.9.8	Tight Shut Open (TSHUT OP)	63
8.9.9	Tight Shut Close (TSHUT CL)	64
8.9.10	Target Position Ramp Up Rate (RAMP UP) and Target Position Ramp Down Rate (RAMP dN) 65	
8.9.11	Digital Input Function (dIF)	67
8.9.12	Digital Input Logic (dI LOGIC).....	67
8.10	Output Configuration (OUT CFG)	68
8.10.1	Position Transmitter Direction (PTM NORM / REVS).....	68
8.10.2	Position Transmitter Zero / End (PTM ZERO / ENd).....	69
8.10.3	HART Feedback Direction (HT NORM / REVS).....	70
8.10.4	Back Calculation (bACKCAL oFF / on).....	71
8.10.5	Digital Output Function (dOF).....	72
8.10.6	Digital Output Logic (dO LOGIC HI / Lo)	73
8.10.7	Analog Output Function (AOF)	74
8.10.8	Analog Output Logic (AO LOGIC Lo / HI).....	75
8.11	Device Configuration (dEV CFG).....	76
8.11.1	Action Setting (ACT)	76
8.11.2	Linear Interpolation (ITP oFF / on).....	77
8.11.3	Lock of Parameters (Write Protect, W UNLOCK / LOCK).....	77
8.11.4	Actual Position View Mode (View Mode, VI NORM / REVS)	78
8.11.5	Polling address setting (POL Addr)	78
8.11.6	Factory Reset (dEFAULT oFF / on).....	79
8.11.7	Positioner Self-Test (SELFTEST).....	80
8.12	Diagnosis Mode (dIAGNd)	81
8.12.1	Default Alarm Settings	81
8.12.2	Process Status (PS)	83
8.12.3	Device Status (dS)	84
8.12.4	View Monitoring Counts (VI CNTS)	86
8.12.5	Diagnostic Limit Configuration (LIMT CFG).....	87
8.12.6	Reset Alarm Status (RST ALRM oFF / on).....	88
8.12.7	View Event Log (EVT LOG).....	89
8.12.8	Partial Stroke Test Record (View PST Result Record, PST RSLT)	90
8.12.9	PST Configuration (PST CFG)	91
8.12.10	Run PST (PST NOW)	92
8.12.11	Periodic PST Test (PST Schedule, PST SCHd oFF / on)	93
8.13	Position information (INFO)	94
8.14	Status and Alarm Code.....	96
9	Main Software Map	99

1 Introduction

1.1 General Information for the users

Thank you for purchasing Rotork YTC Limited products. Each product has been fully inspected after its production to offer you the highest quality and reliable performance. Please read the product manual carefully prior to installing and commissioning the product.

- Installation, commissioning, and maintenance of the product may only be performed by trained specialist personnel who have been authorized by the plant operator accordingly.
- The manual should be provided to the end-user.
- **Factory Mutual approved Intrinsically Safe and Non-Incendive units must be Installed Per drwg SKC_XXXXX_XXXXXX.pdf**
- **CSA approved Intrinsically Safe and Non-Incendive units must be Installed Per drwg SKC-XXXX.pdf**
- The manual can be altered or revised without any prior notice. Any changes in product's specification, design, and/or any components may not be printed immediately but until the following revision of the manual.
- When the manual refers to "**Valve Zero / Zero**" means the final valve position upon pneumatic pressure has been fully exhausted from positioner's OUT1 port. For example, the valve zero position may differ between linear direct and reverse actions. (DA/RA)
- The manual should not be duplicated or reproduced for any purpose without prior approval from Rotork YTC Limited, Gimpo-si, South Korea.
- In case of any other problems that are not stated in this manual, please make immediate contact to Rotork YTC Limited.
- Positioner is an accessory of the control valve, so please make sure to read the applicable instruction manual of the control valve prior to installation and operation.

1.2 Manufacturer Warranty

- For the safety, it is important to follow the instructions in the manual. Manufacturer will not be responsible for any damages caused by user's negligence.
- Any modifications or repairs to the product may only be performed if expressed in this manual. Injuries and physical damages caused by customer's modifying or repairing the product without a prior consultation with Rotork YTC Limited will not be compensated. If any alterations or modifications are necessary, please contact Rotork YTC Limited directly.
- The warranty period of the product is (18) months from the date of shipment unless stated otherwise. Date of shipment can be checked by providing the LOT NO. or SERIAL NO. to us.
- Manufacturer warranty will not cover products that have been subjected to abuse, accidents, alterations, modifications, tampering, negligence, misuse, faulty installation, lack of reasonable care, repair or service in any way that is not contemplated in the documentation for the product, or if the model or serial number has been altered, tampered with, defaced or removed; damages

that occurs in shipment, due to act of God, failure due to power surge, or cosmetic damage. Improper or incorrectly performed maintenance will void this limited warranty.

- For detailed warranty information, please contact the corresponding local Rotork YTC Limited office or main office in South Korea.

1.3 Explosion Proof Warning (Only for Intrinsic safety type positioners)

Please ensure the unit is being used and installed in conformity with local, regional, and national explosion proof within the proper safety barrier environment.



- Refer to “2.7 Certifications”
- Explosion proof type of cables and gaskets should be used, when explosion gases are present at the installation site.
- Positioner has 2 ports for power connection. Explosion proof type wires and packing should be used. Blind plug is required when any port is not being used.
- Ring terminal with surface area of more than 1.25mm² with M4 spring washer should be used to connect the power.
- For external ground terminal, ring terminal with surface area of more than 5.5mm² should be used.
- Wiring in these applications shall utilize appropriate methods for Class I, Division 2 / Zone 2
- Substitution of components may impair intrinsic safety.
- Substitution of components may impair suitability for Class I, Division 2 (FM/CSA: Class I, Division 1, Division 2)
- EXPLOSION HAZARD. Do not connect or disconnect wiring unless all sources of power have been removed or the area is known to be non-hazardous.
(French) RISQUE D'EXPLOSION. Ne pas raccorder ou débrancher le câblage à moins Toutes les sources d'énergie ont été enlevées ou la zone est connue pour être non dangereux.
- The enclosure of model YT-3700 contains aluminum, which is considered to constitute a potential risk of ignition when subjected to impact or friction. Care must be used during installation in locating this equipment to prevent impact or friction
- Some of the enclosure parts are made of non-metallic materials. To prevent the risk of Electrostatic sparking, clean the enclosure only with a damp cloth.
- The product must be installed in such a manner as to minimize the risk of impact or friction with other metal surfaces.
- For Intrinsically Safe installations, the product must be connected to suitably rated intrinsically safe equipment, and must be installed in accordance with applicable intrinsically safe installation standards.

2 Product Description

2.1 General

YT-3700 / 3750 series Smart Valve Positioner accurately controls valve stroke in response to an input signal of 4~20mA from the controller. Built-in micro-processor optimizes the positioner's performance and provides unique functions such as **Auto-Calibration, PID Control, and HART Protocol Communications.**

2.2 Main Features and Functions

- LCD display enables users to monitor the positioner status.
- User will easily understand the method of using 4 buttons because it work same in all versions of firmware interfaces.
- When unexpected situation like momentary blackout happens, our positioner boot-time only take 0.5 second and this can minimize the travel of valve which consequentially increase the safety of system.
- Positioner operates normally even there are sudden changes in supply pressure and / or high vibration environment.
- The method of Auto Calibration is very simple.
- As an advantage of having very low air consumption, It could greatly reduce operating costs in large-scale plants.
- It is compatible with most of controllers.
- Orifices can be installed even in the field to minimize the hunting occurrence and optimize operating conditions.
- Various information about positioner can be processed by HART communication.
- Valve system becomes more stable by outputting analog feedback signal.
- Different valve characteristics can be adjusted – Linear, Quick Open, Equal Percentage, and User Set which user can make 5 or 21 points characterizations.
- Tight Shut – Close and Shut - Open can be set.
- PID parameters can be adjusted in the field without any additional communicator.
- A/M switch can be used to direct supply air to the actuator or to manually operate the positioner or valve without any signal.
- Split range 4~12mA or 12~20mA can be set.
- Operating temperature for positioners is -30 ~ 85°C or -40 ~ 85°C (Please check certified explosion proof temperature)
- Hand calibration function can set Zero point or End point manually.
- It has IP66 protection grade.
- Polyester powder coating resists the corrosion process. (except YT-3750).
- Maintenance of the positioner is easy because of modularized inner structure.

2.3 Label Description

- MODEL : Indicates the model number and additional options.
- EXPLOSION PROOF : Indicates certified explosion proof grade.
- INGRESS PROTECTION : Indicates enclosure protection grade.
- INPUT SIGNAL : Indicates input signal range.
- OPERATING TEMP. : Indicates the allowable operating temperature.
- SUPPLY PRESSURE : Indicates the supply pressure range.
- SERIAL NUMBER : Indicates unique serial number.
- YEAR.MONTH : Indicates manufactured year and month.

- INTRINSIC SAFETY / NONINCENDIVE : Indicates intrinsic safety explosion proof grade.
- AMBIENT TEMP. : Indicates the allowable ambient temperature for explosion proof.
- Ui, li, Pi, Ci, Li : Indicates the allowable electrical data in the certificate.
 ATEX: Ui = 28 V, li = 93 mA, Pi = 651 mW, Ci = 0.6 nF, Li = 10 μH
 FM: Ui = xx V, li = xx mA, Pi = xxx mW, Ci = x.xx nF, Li = xx μH
 You can also see the details in the certificate.

※ Precautions



Be careful not to apply volatile solvent (hardener of instant adhesive, acetone, WD-40, etc.) to the sticker nameplate. Printed contents may be erased.

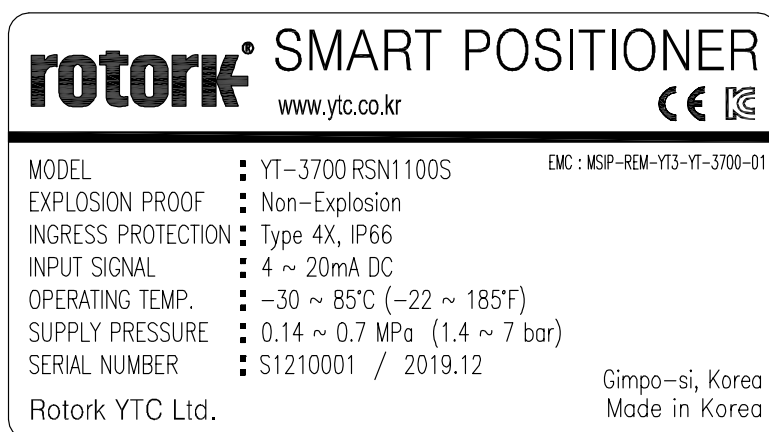

Fig. L-1: YT-3700 Non-explosion proof

rotork® SMART POSITIONER		www.ytc.co.kr	CE 2004 Ex II 2 G&D	RoHS	REACH
MODEL	: YT-3700RSi1100S	EPS 19 ATEX 1 145 X			
INTRINSIC SAFETY/ NONINCENDIVE	: Ex ia IIC T5/T6 Gb; Ex iaD 21 T100/T85	IECEX EPS 19.0069X NEPSI : GYJ19.1360X			
INGRESS PROTECTION	: IP66	KCs : 19-KA2BO-0874X			
INPUT SIGNAL	: 4~20mA DC	19-KA2BO-0877X			
AMBIENT TEMP.	: T5 : -30 ~ 60°C(-22 ~ 140°F) T6 : -30 ~ 40°C(-22 ~ 104°F)	19-KA2BO-0867X			
		19-KA2BO-0878X			
SUPPLY PRESSURE	: 0.14 ~ 0.7 MPa (1.4 ~ 7 bar)	19-KA2BO-0861X			
Ui, li, Pi, Ci, Li,	: See certificate or product manual	19-KA2BO-0879X			
SERIAL NUMBER	: S1210001 / 2019.12	EMC : R-R-YT3-YT-3700-01			
Rotork YTC Ltd.		Gimpo-si, Korea Made in Korea			
 TO PREVENT IGNITION OF FLAMMABLE OR COMBUSTIBLE WARNING ATMOSPHERES, DISCONNECT POWER BEFORE SERVICING.					

Fig. L-2: YT-3700 Intrinsic safety type (ATEX, IECEX, KCs, NEPSI)





  SMART POSITIONER Rotork YTC Ltd. Gimpo-si, Korea www.ytc.co.kr Made in Korea	MODEL	: YT-3700 RSA1100L		
	INTRINSIC SAFETY/ NONINCENDIVE	: Class I, Division 1&2, Grps ABCD T5/T6 Class II, Division 1&2, Grps EFG T100°C/T85°C; CI III Class I, Zone 0, AEx ia IIC T5/T6(FM) Ex ia IIC T5/T6 Ga; Ex tb IIIC T100°C/T85°C Db		
	INGRESS PROTECTION	: Type 4X(FM), IP66		
	INPUT SIGNAL	: 4 ~ 20mA DC		
	ELECTRICAL RATINGS	: Rated 30 Vdc max, 100mA max, Class 2/SELV		
	AMBIENT TEMP.	: T5 : -40 ~ 60°C(-40 ~ 140°F) T6 : -40 ~ 40°C(-40 ~ 104°F)		
	SUPPLY PRESSURE	: 0.14 ~ 0.7 MPa (1.4 ~ 7 bar)		
	ENTITY/ NIFW PARAMETERS	: FM : IS with Entity & NI per System Drawing SKC-XXXXX_XXXXX CSA : IS with Entity per System Drawing SKC-XXXX		
	SERIAL NUMBER	: S1210001 / 2019.03		
 * POTENTIAL ELECTROSTATIC CHARGING HAZARD : SEE INSTRUCTIONS. * PISQUE POTENTIEL DE CHARGE ELECTROSTATIQUE. : VOIR LES INSTRUCTIONS.		  APPROVED CSA XX.XXXXXXX.X Eria / XXXXXX		

Fig. L-3: YT-3700 Intrinsic safety type (FM, CSA)

 УМНЫЙ ПОЗИЦИОНЕР Gimpo-si, Korea Rotork YTC Ltd. www.ytc.co.kr Сделано в Корее	 	RU Д-KR.AXXX.B.XXXXX
	Модель	: YT-3700 LSN1100S
	Взрывозащищенный	: Не-взрыв
	Степень защиты	: IP66
	Входной сигнал	: 4 ~ 20mA DC
	Рабочая Температура	: -30 ~ 85°C (-22 ~ 185°F)
	Давление питания	: 0,14 ~ 0,7 МПа (1,4 ~ 7 бар)
	Серийный номер	: S1210001 / 12.2019

Fig. L-4: YT-3700 Non-explosion proof (TRCU)



		RU C-KR.AMXX.B.XXXXX/XX	
		УМНЫЙ ПОЗИЦИОНЕР	Модель : YT-3700 RD1100L Взрывозащищенный : 1Ex ia IIC T6/T5 Gb X Ex ia IIIC T85°C/T100°C Db X Степень защиты : IP66 Входной сигнал : 4 ~ 20mA DC Окр. Темп. : T5 : -40 to 60°C(-40 to 140°F) T6 : -40 to 40°C(-40 to 104°F) Макс. раб. давл. : 0,14 ~ 0,7 МПа (1,4 ~ 7 бар) Ui, li, Pi, Ci, Li, : См сертификат Серийный номер : S1210001 / 2019.12
Gimpo-si, Korea Rotork YTC Ltd. www.ytc.co.kr Сделано в Корее			

Fig. L-5: YT-3700 Intrinsic safety type (TRCU)



 SMART POSITIONER www.ytc.co.kr		 DNV 19.0145 X
NÚMERO DO MODELO : YT-3700 RS1100L MARCAÇÃO : Ex ia IIC T6/T5 Gb Ex ia IIIC T85°C/T100°C Db		
GRAU DE PROTEÇÃO : IP66 SINAL DE ENTRADA : 4~20mA TEMPERATURA AMBIENTE : T5 : -40 ~ 60°C(-40 ~ 140°F) T6 : -40 ~ 40°C(-40 ~ 104°F)		
PRESSÃO DE ALIMENTAÇÃO : 0.14 ~ 0.7 MPa (1.4 ~ 7 bar) Ui, li, Pi, Ci, Li, : Veja o certificado ou o manual do produto NÚMERO DE SÉRIE : S1210001 / 2019.12	Gimpo-si, Korea Made in Korea	
Rotork YTC Ltd.		

Fig. L-6: YT-3700 Intrinsic safety type (INMETRO)



 SMART POSITIONER www.ytc.co.kr		
MODEL : YT-3750RSN1100S EXPLOSION PROOF : Non-Explosion INGRESS PROTECTION : Type 4X, IP66 INPUT SIGNAL : 4 ~ 20mA DC OPERATING TEMP. : -30 ~ 85°C (-22 ~ 185°F) SUPPLY PRESSURE : 0.14 ~ 0.7 MPa (1.4 ~ 7 bar) SERIAL NUMBER : S1210001 / 2019.12		
Rotork YTC Ltd.		Gimpo-si, Korea Made in Korea

Fig. L-7: YT-3750 Non-explosion proof





rotork®		SMART POSITIONER	
www.ytc.co.kr		   	
MODEL	: YT-3750 RS1100L	EPS 19 ATEX 1 145 X	
INTRINSIC SAFETY/ NONINCENDIVE	: Ex ia IIC T5/T6 Gb; Ex iaD 21 T100/T85	IECEX EPS 19.0069X	
	: Ex ia IIIC T100°C/T85°C Db	NEPSI : GYJ19.1360X	
INGRESS PROTECTION	: IP66	KCs : 19-KA2BO-0862X	
INPUT SIGNAL	: 4 ~ 20mA DC	19-KA2BO-0880X	
AMBIENT TEMP.	: T5 : -40 ~ 60°C(-40 ~ 140°F)	19-KA2BO-0863X	
	: T6 : -40 ~ 40°C(-40 ~ 104°F)	19-KA2BO-0882X	
SUPPLY PRESSURE	: 0.14 ~ 0.7 MPa (1.4 ~ 7 bar)	19-KA2BO-0860X	
Ui, li, Pi, Ci, Li,	: See certificate or product manual	19-KA2BO-0881X	
SERIAL NUMBER	: S1210001 / 2019.12		
Rotork YTC Ltd.	 WARNING TO PREVENT IGNITION OF FLAMMABLE OR COMBUSTIBLE ATMOSPHERES, DISCONNECT POWER BEFORE SERVICING.	Gimpo-si, Korea	Made in Korea

Fig. L-8: YT-3750 Intrinsic safety type (ATEX, IECEX, KCs, NEPSI)



rotork®		SMART POSITIONER	
www.ytc.co.kr			
MODEL	: YT-3750 RSA1100L	CSA XX.XXXXXXX.X	
INTRINSIC SAFETY/ NONINCENDIVE	: Class I, Division 1&2, Grps ABCD T5/T6	Exia / XXXXXX	
	: Class II, III, Division 1&2, Grps EFG T100°C/T85°C; CI III		
	: Class I, Zone 0, AEx ia IIC T5/T6(FM)		
	: Ex ia IIC T5/T6 Ga; Ex tb IIIC T100°C/T85°C Db		
INGRESS PROTECTION	: Type 4X(FM), IP66		
INPUT SIGNAL	: 4 ~ 20mA DC		
ELECTRICAL RATINGS	: Rated 30 Vdc max, 100mA max, Class 2/SELV		
AMBIENT TEMP.	: T5 : -40 ~ 60°C(-40 ~ 140°F)		
	: T6 : -40 ~ 40°C(-40 ~ 104°F)		
SUPPLY PRESSURE	: 0.14 ~ 0.7 MPa (1.4 ~ 7 bar)		
ENTITY/ NIFW PARAMETERS	: FM : IS with Entity & NI per System Drawing SKC-XXXXX_XXXXX		
	: CSA : IS with Entity per System Drawing SKC-XXXX		
SERIAL NUMBER	: S1210001 / 2019.03		
Rotork YTC Ltd.	 WARNING * POTENTIAL ELECTROSTATIC CHARGING HAZARD : SEE INSTRUCTIONS.	Gimpo-si, Korea	Made in Korea
	* PISQUE POTENTIEL DE CHARGE ELECTROSTATIQUE : VOIR LES INSTRUCTIONS.		

Fig. L-9: YT-3750 Intrinsic safety type (FM, CSA)

rotork®		Ex EAC		RU C-KR.AMXX.B.XXXXX/XX
УМНЫЙ ПОЗИЦИОНЕР				
www.ytc.co.kr				
Модель	: YT-3750 RSE1320L			
Взрывозащищенный	: 0Ex ia IIC T6/T5 Ga X			
	: Ex ia IIIC T85°C/T100°C Da X			
Степень защиты	: IP66			
Входной сигнал	: 4 ~ 20mA DC			
Окр. Темп.	: T5 : -40 to 60°C(-40 to 140°F)			
	: T6 : -40 to 40°C(-40 to 104°F)			
Макс. раб. давл.	: 0,14 ~ 0,7 МПа (1,4 ~ 7 бар)			
Ui, li, Pi, Ci, Li,	: См сертификат			
Серийный номер	: S1210001 / 2019.12			
Gimpo-si, Korea				
Rotork YTC Ltd.				
www.ytc.co.kr				
Сделано в Корее				

Fig. L-10: YT-3750 Intrinsic safety type (TRCU)

rotork®		SMART POSITIONER	
		www.ytc.co.kr	
NÚMERO DO MODELO	: YT-3750 RSi1320L	Segurança  DNV 19.0145 X	○
À PROVA DE EXPLOÇÃO	: Ex ia IIC T6/T5 Gb Ex ia IIC T85°C/T100°C Db		
○ PROTEÇÃO DE INGRESSO	: IP66		
SINAL DE ENTRADA	: 4~20 mA		
TEMPERATURA AMBIENTE	: T5 : -40 ~ 60°C (-40 ~ 140°F) T6 : -40 ~ 40°C (-40 ~ 104°F)		
PRESSÃO DE ALIMENTAÇÃO	: 0.14 ~ 0.7 MPa (1.4 ~ 7 bar)		
Ui, li, Pi, Ci, Li,	: Veja o certificado ou o manual do produto		
NÚMERO DE SÉRIE	: S1210001 / 2019.12		
Rotork YTC Ltd.		Gimpo-si, Korea Made in Korea	

Fig. L-11: YT-3750 Intrinsic safety type (INMETRO)

2.4 Product Code

YT-3700 / 3750 1 2 3 4 5 6 7 8

1	Motion Type	L : Linear (Positioner is attached the right yoke of actuator.) R : Rotary
2	Acting type	S : Single D : Double
3	Explosion Proof	N : Non-Explosion i : ATEX, IECEX, KCs, NEPSI, INMETRO : Ex ia IIC T5/T6 Gb, Ex ia IIIC T100°C/T85°C Db, IP66 A : FM & CSA : Class I, Division 1&2 Groups ABCD T5/T6 Class II, Division 1&2 Groups EFG T100°C/T85°C; Class III Class I, Zone 0, AEx ia IIC T5/T6, Ex ia IIC T5/T6 Ga; Ex tb IIIC T100°C/T85°C Db E : Intrinsic safety for TRCU
4	Lever Type	0 : 10 ~ 40 mm (Standard type) 1 : 20 ~ 100 mm (Standard type) 2 : 90 ~ 150 mm (Standard type)
	Linear	
	Rotary	5 : Namur
5	Conduit - Air Connection Type	1 : G 1/2 – Rc 1/4 2 : G 1/2 – 1/4 NPT (YT-3750 is available for No. 2 ONLY) 3 : G 1/2 – G 1/4 4 : M20x1.5P – 1/4 NPT 5 : 1/2 NPT – 1/4 NPT
6	Communication	2 : HART Communication
7	Option	0 : None 1 : + 4 to 20 mA feedback 4 : + 4 to 20 mA feedback + Limit Switch Mech.(not available with NCS) ¹⁾ 5 : + 4 to 20 mA feedback + Limit Switch Inductive Prox. (not available with NCS) ²⁾ ※ DI/DO cannot be included at Limit Switch options
8	Operating Temp. (Non-explosion proof) ³⁾	S : -30°C ~ 85°C (-22°F ~ 185°F, except TRCU explosion proof) L : -40°C ~ 85°C (-40°F ~ 185°F) A : -55°C ~ 85°C (-67°F ~ 185°F, only TRCU explosion proof)

¹⁾ This option is only available for “S”, “L” in 8 operating temp.

²⁾ This option is only available for “S” in 8 operating temp.

³⁾ This option is just the normal operating temperature of the product and is not related to explosion proof temperature. See “2.7 Certificates” for explosion proof temperature.

2.5 Product Specification

Model		YT-3700		YT-3750	
Housing Material		Aluminum		Stainless Steel 316	
Motion Type		Linear	Rotary	Linear	Rotary
Acting Type		Single / Double			
Input Signal		4~20mA DC			
Minimum Current Signal		3.8mA			
Supply Pressure		0.14 ~ 0.7 MPa (1.4 ~ 7 bar)			
Stroke		10 ~ 150 mm	55 ~ 110°	10 ~ 150 mm	55 ~ 110°
Impedance		Max. 500Ω @ 20mA DC			
Air Connection		Rc 1/4 or 1/4 NPT or G 1/4		1/4 NPT	
Gauge Connection		Rc 1/8 or 1/8 NPT		1/8 NPT	
Conduit Entry		G 1/2 or 1/2 NPT or M20x1.5P		G 1/2	
Ingress Protection		IP66, Type 4X(FM)			
Explosion Proof		1. Non-Explosion 2. ATEX, IECEx, KCs, NEPSI, TRCU, INMETRO: Ex ia IIC T5/T6 Gb, Ex ia IIIC T100°C/T85°C Db, IP66 3. FM & CSA: Class I, Division 1&2 Groups ABCD T5/T6 Class II, Division 1&2 Groups EFG T100°C/T85°C; Class III Class I, Zone 0, AEx ia IIC T5/T6, Ex ia IIC T5/T6 Ga; Ex tb IIIC T100°C/T85°C Db			
Operating Temperature	Standard Type	-30°C ~ 85°C (-22°F ~ 185°F) Inductive proximity limit switch internal type : -25°C ~ 85°C (-13°F ~ 185°F) Except TRCU explosion proof			
	Low Temp. Type	-40°C ~ 85°C (-40°F ~ 185°F)			
	Arctic Temp. Type	-55°C ~ 85°C (-67°F ~ 185°F, only TRCU explosion proof)			
Ambient Temperature Of Explosion Proof	T5	-40°C ~ 60°C (-40°F ~ 140°F) TRCU : -55°C ~ 60°C (-67°F ~ 140°F)			
	T6	-40°C ~ 40°C (-40°F ~ 104°F) TRCU : -55°C ~ 40°C (-67°F ~ 104°F)			
Linearity		±0.5% F.S.			
Hysteresis		±0.5% F.S.			
Sensitivity		±0.2% F.S.			
Repeatability		±0.3% F.S.			
Flow Capacity		70 LPM (Sup.=0.14 MPa)			
Air Consumption		Below 2 LPM (Sup.=0.14 MPa @ idle)			
Output Characteristic		Linear, Quick Open, EQ%, User Set			
Vibration		No Resonance up to 100Hz @ 6G			
Humidity		5-95% RH @ 40°C			
Communication		HART Communication (HART 7)			
Feedback Signal (Option)		4~20mA (DC 9~28V)			
Digital In/Out		Detail spec. refer to 2.6. ※ N/A at Limit switch options.			
Weight		2 kg (4.4 lb)		5.1 kg (11.2 lb)	

Painting	Polyester Powder Coating	-
-----------------	--------------------------	---



Tested under ambient temperature of 20°C, absolute pressure of 760mmHg, and humidity of 65%.
Please contact Rotork YTC Limited for detailed testing specification.

2.6 Specification of Digital In, Digital out

1) Digital In

- Control voltage : 0 ~ 5V DC → Logical switching state "0"
11 ~ 28V DC → Logical switching state "1"

- Current Max. 4mA

2) Digital Out

- Supply voltage 5 ~ 28V DC
- Current < 1mA, Switching state logical "0"
- Current > 2.2mA, Switching state logical "1"

2.7 Certifications

※ All certifications below are posted on Rotork YTC Limited homepage(www.ytc.co.kr).

➤ **KCs (Korea, Pending)**

Type : Intrinsic safety

Rating : Ex ia IIC T6/T5, Ex ia IIIC T85°C/T100°C

Certification No. : 19-KA2BO-0874X / 19-KA2BO-0877X (YT-3700 gas / dust)

19-KA2BO-0867X / 19-KA2BO-0878X {YT-3700+LS(Dry contact) gas / dust}

19-KA2BO-0861X / 19-KA2BO-0879X {YT-3700+LS(Non-contact) gas / dust}

19-KA2BO-0862X / 19-KA2BO-0880X (YT-3750 gas / dust)

19-KA2BO-0863X / 19-KA2BO-0882X {YT-3750+LS(Dry contact) gas / dust}

19-KA2BO-0860X / 19-KA2BO-0881X {YT-37500+LS(Non-contact) gas / dust}

Ambient temperature : -40 ~ +40°C (T6/T85°C) / -40 ~ +60°C (T5/T100°C)

➤ **ATEX**

Type : Intrinsic safety

Rating : II 2G Ex ia IIC T5/T6 Gb, II 2D Ex ia IIIC T100°C/T85°C Db, IP6X

Certification No. : EPS 19 ATEX 1 145 X

Ambient temperature : -40 ~ +60°C (T5), -40 ~ +40°C (T6)

➤ **IECEX**

Type : Intrinsic safety

Rating : Ex II 2G Ex ia IIC T5/T6 Gb, Ex II 2D Ex ia IIIC T100°C/T85°C Db, IP6X

Certification No. : IECEX EPS 19.0069X

Ambient temperature : -40 ~ +60°C (T5/T100°C), -40 ~ +40°C (T6/T85°C)

➤ **NEPSI (Pending)**

Type : Intrinsic safety

Rating : Ex ia IIC T5/T6 Gb

Ex iaD 21 T100/T85

Certification No. : GYJ19.1360X

➤ **TRCU (Pending)**

Type : Intrinsic safety

Rating : 1Ex ia IIC «T6 ... T5» Gb X, Ex ia IIIC «T85 ° C ... T100 ° C» Db X

Certification No. : RU C-KR.MIOXX.B.XXXXX

Ambient temperature : -55 ~ +60°C (T5/T100°C), -55 ~ +40°C (T6/T85°C)

➤ **FM (Pending)**

Rating : Class I, Div 1, Groups ABCD

Class I, Zone 0 AEx ia IIC

Class II/III, Div 1, Groups EFG

Class I, II, III, Div 2, Groups ABCDEFG

NEMA Type 4X, IP66

Certificate No.: FMXXUSXXXXX

Ambient temperature : -40 to +60°C(T5), -40 to +40°C(T6)

➤ **CSA (Pending)**

Type : Intrinsic safety

Rating : Class I, Division 1&2 Groups ABCD T5/T6

Class II, Division 1&2 Groups EFG T100°C/T85°C

Class III

Ex ia IIC T5/T6 Ga

Ex tb IIIC T100°C/T85°C Db

IP66

Certificate No.: CSA XX.XXXXXXXX

Ambient temperature : -40 to +60°C(T5), -40 to +40°C(T6)

➤ **INMETRO (Brazil)**

Type : Intrinsic safety

Rating : Ex ia IIC T5/T6 Gb, Ex ia IIIC T100°C/T85°C Db, IP66

Certification No. : DNV 19.0145 X

Ambient temperature : -40 ~ +60°C (T5), -40 ~ +40°C (T6)

➤ **SIL2 (in a redundant structure up to SIL 3, Pending)**

Intended application : Safety function is defined as to move into fail-safe-position, when signal to positioner is interrupted.

Certification No. : XXX/V XXX.XX/XX

➤ **Electromagnetic Compatibility (EMC)**

- EMC directive 2014/30/EC from April 2016

- EC Directive for CE conformity marking

- Registration No. : R-R-YT3-YT-3700-01

R-R-YT3-YT-3700LSN-01

2.8 Parts and Assembly

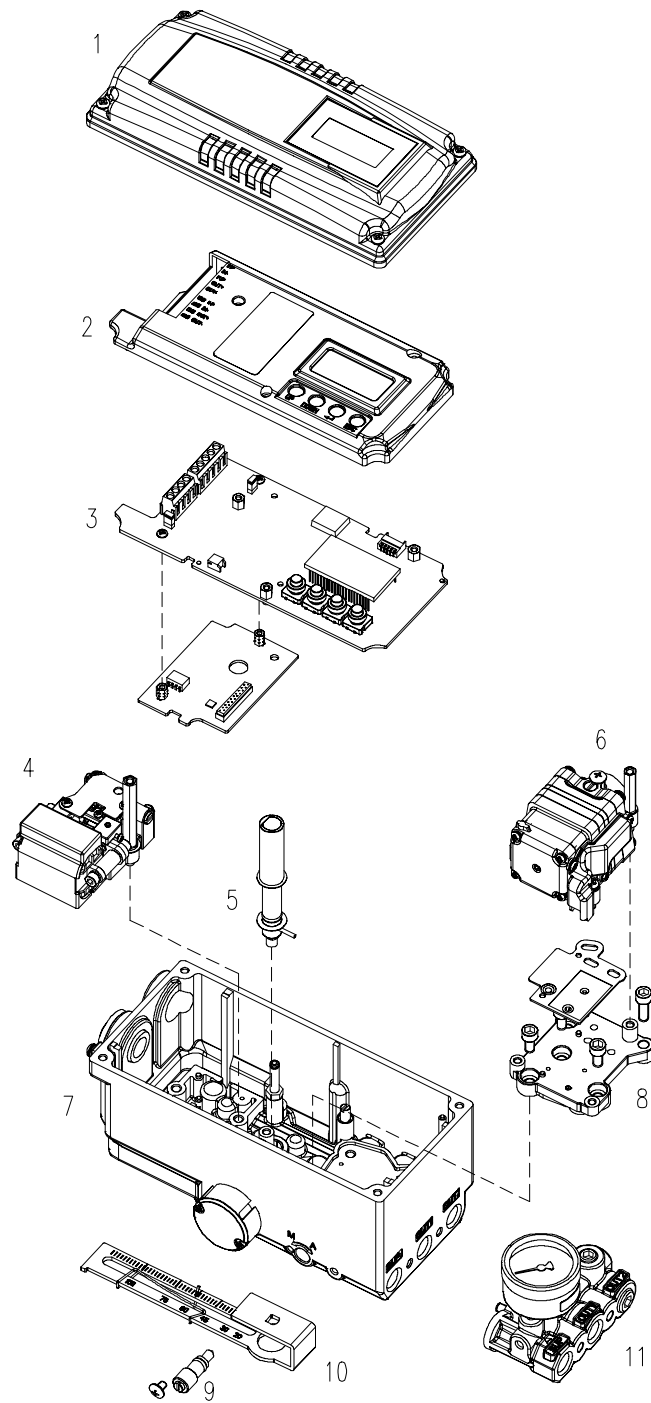

Fig. 2-1: Exploded view of standard type positioner

- | | |
|-------------------------|-----------------------|
| 1. Base Cover | 7. Base body |
| 2. PCB Cover | 8. Pilot Block |
| 3. Main PCB | 9. Auto Manual Switch |
| 4. Torque Motor | 10. Feedback Lever |
| 5. Main Shaft (for NCS) | 11. Gauge Block |
| 6. Pilot | |

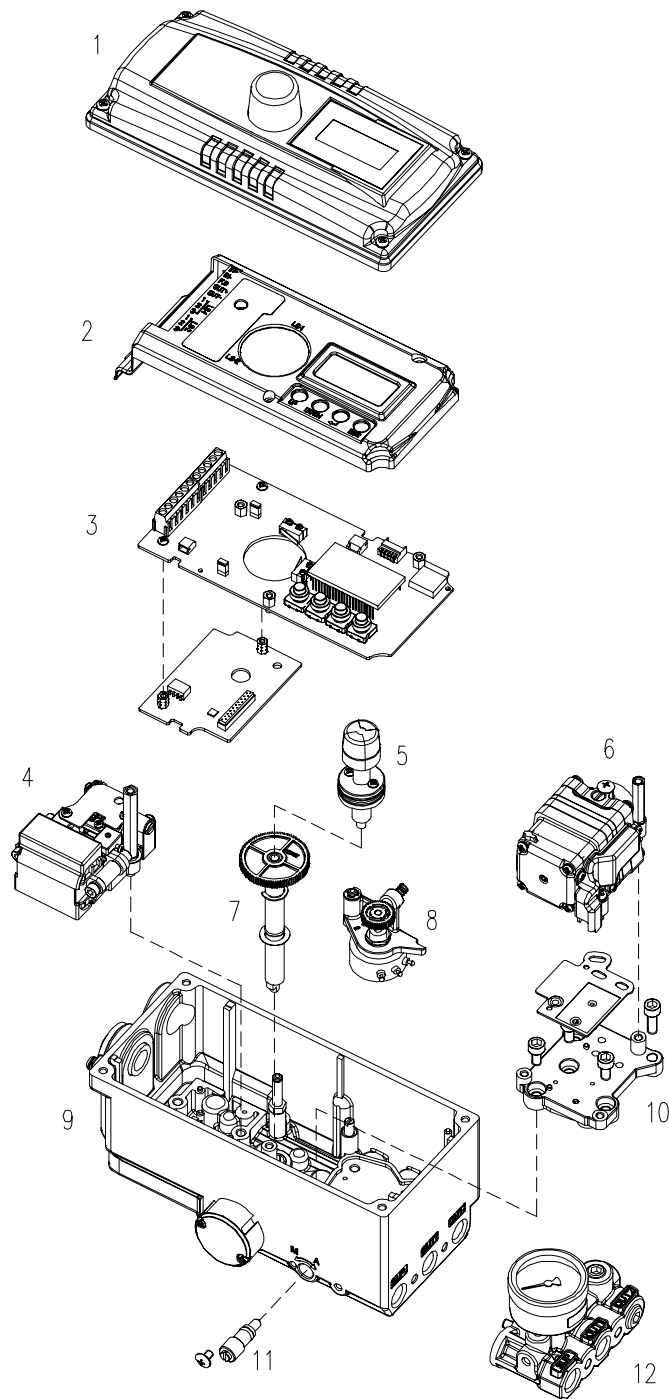

Fig. 2-2: Exploded view of limit switch type positioner

- | | |
|------------------------------------|------------------------|
| 1. Base Cover | 8. Potentiometer |
| 2. PCB Cover | 9. Base body |
| 3. Main PCB(limit switch type) | 10. Pilot Block |
| 4. Torque Motor | 11. Auto Manual Switch |
| 5. Cam assembly | 12. Feedback Lever |
| 6. Pilot | 13. Gauge Block |
| 7. Main Shaft(potentiometer type). | |

2.9 Product Dimension

2.9.1 YT-3700

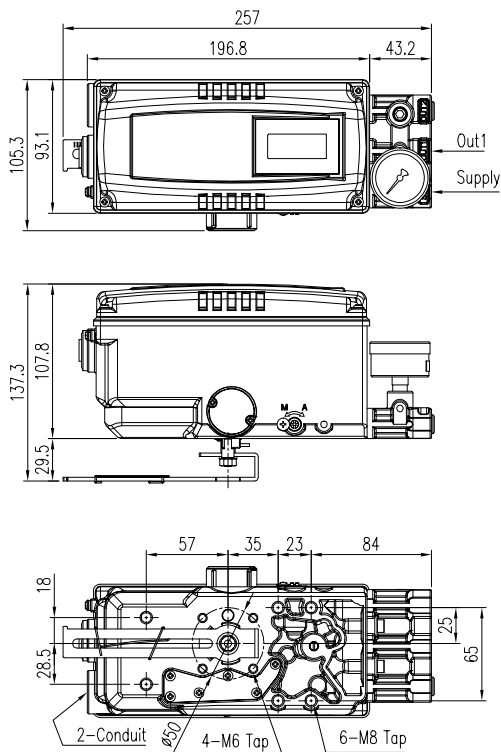

Fig. 2-3: YT-3700L

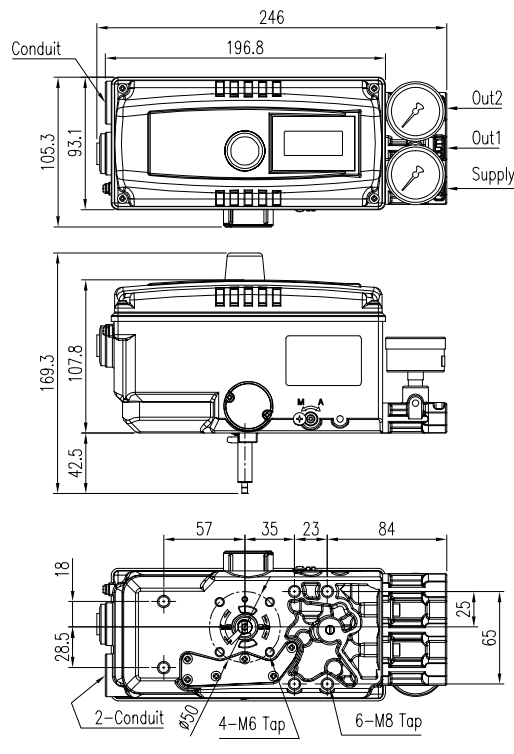

Fig. 2-4: YT-3700R+LS

2.9.2 YT-3750

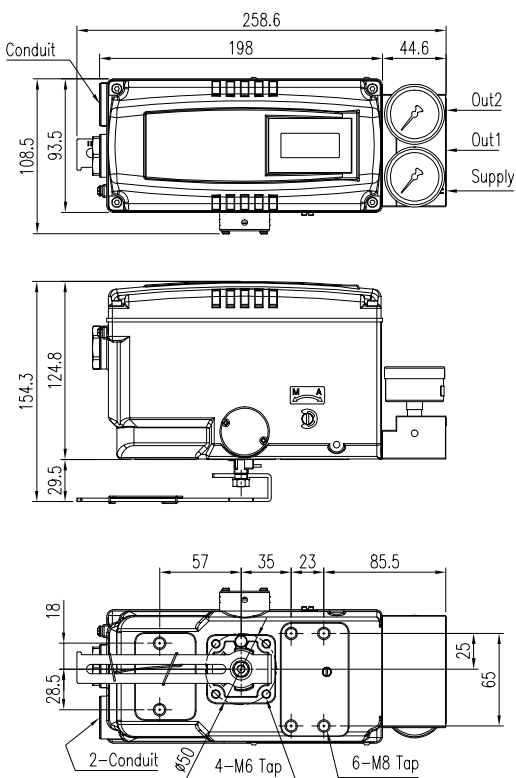

Fig. 2-5: YT-3750L

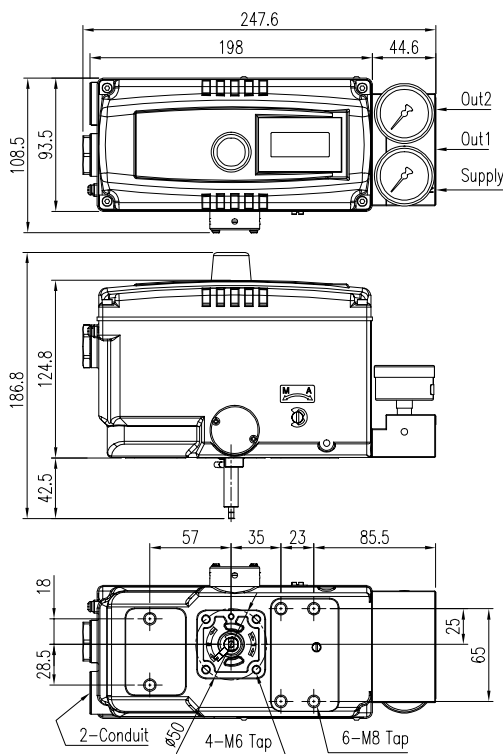

Fig. 2-6: YT-3750R+LS

3 Installation

3.1 Safety

When installing a positioner, please ensure to read and follow safety instructions.



- Any input or supply pressures to valve, actuator, and / or to other related devices must be turned off.
- Use bypass valve or other supportive equipment to avoid entire system “shut down”.
- Ensure there is no remaining pressure in the actuator.
- The positioner has a vent cover to exhaust internal air and drain internal condensation water. When installing the positioner, make sure the vent cover must be facing downward. Otherwise, the condensation water could cause damages to PCB.

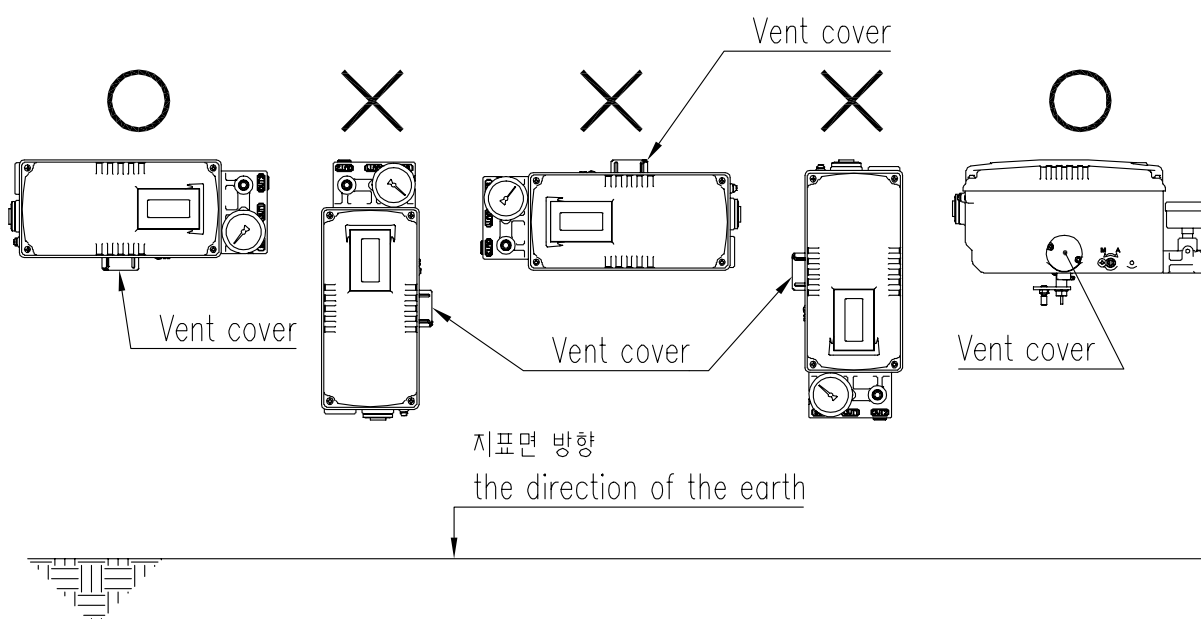

Fig. 3-1: The correct positions of a vent cover

- ※ Installed in accordance with the National Electrical Code(NEC), ANSI/NFPA 70, or CEC Part 1 as applicable.(FM approved product)

3.2 Tools for installation

- Hex key set for hex socket cap bolts
- (+) & (-) Screw drivers
- Spanners for hexagonal-head bolts

3.3 Linear positioner Installation

Linear positioner should be installed on linear motion valves such as globe or gate type which uses spring return type diaphragm or piston actuators.

3.3.1 Linear positioner Installation of Standard lever type

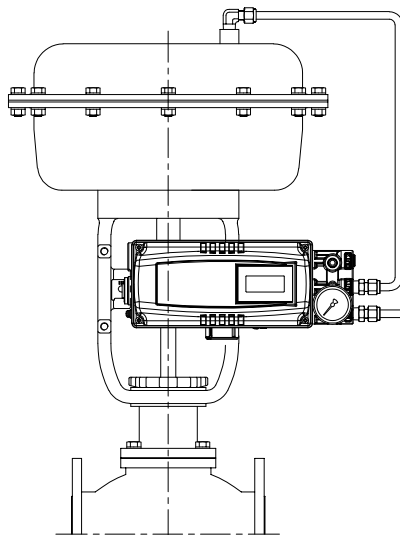

Fig. 3-2: Installation of linear positioner example

Before proceeding with the installation, ensure following components are available.

- Positioner
- Feedback lever and lever spring
- M6 nut and spring washer (fastening feedback lever to a main shaft)
- Bracket, bolts and washers for positioner or sensor – not supplied with the positioner
- Connection bar – not supplied with the positioner

3.3.2 Safety

Proper bracket must be made in order to adapt the positioner on the actuator yoke.

Please consider following important points when a bracket is being designed.

- Positioner's feedback lever must be vertical to the valve stem at 50% of the valve stroke.
- The connection bar of the actuator clamp for the feedback lever should be installed in such a way that the valve stroke length coincides with the corresponding figure in "mm" marked on the feedback lever. Improper setting may cause poor linearity



3.3.3 Standard lever type positioner Installation Steps

1. Assemble the positioner or remote sensor with the bracket made in previous step by fastening the bolts.

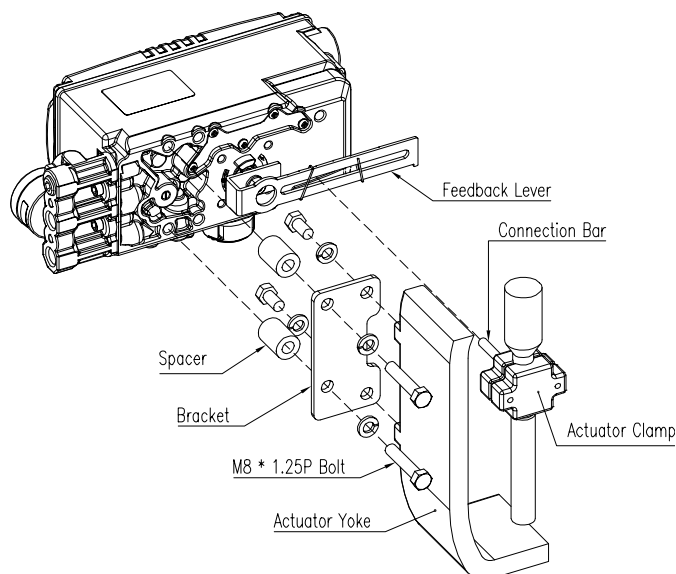

Fig. 3-3: Linear positioner, bracket, actuator

2. Attach the positioner with the bracket to the actuator yoke – **DO NOT TIGHTEN THE BRACKET COMPLETELY.**
3. Connect connection bar to the actuator clamp. The hole gap on the feedback lever is 6.5mm so the connection bar's outer diameter should be less than 6mm.
4. Connect an air-filter regulator to the actuator temporarily. Supply enough air pressure to the actuator in order to position the valve stroke at 50% of the total stroke.

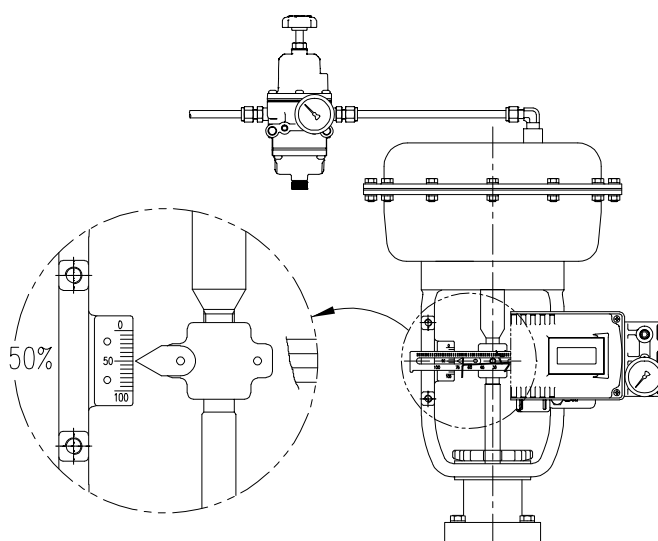

Fig. 3-4: YT-3700L / 3750L

5. Insert the connection bar between the feedback lever and lever spring. The connection bar must be located upward from the lever spring as shown below left figure. If it is located downward from the lever spring as shown below right figure, the connection bar or the lever spring will be worn out quickly because of excessive strong tension.

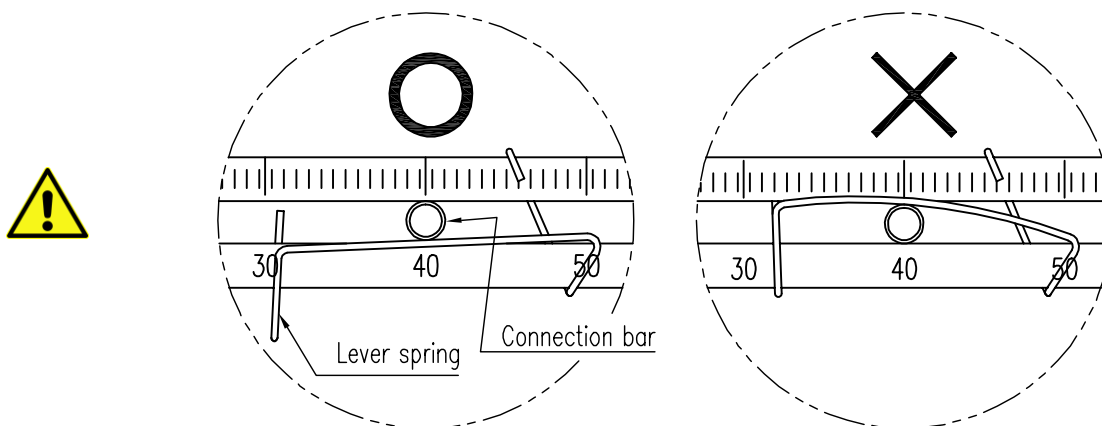

Fig. 3-5: Proper way to insert connection bar between feedback lever and lever spring

6. Check if feedback lever is vertical to the valve stem at 50% of the valve stroke. If it is not vertical, adjust the bracket or the connection bar to make vertical. Improper installation may cause poor linearity.

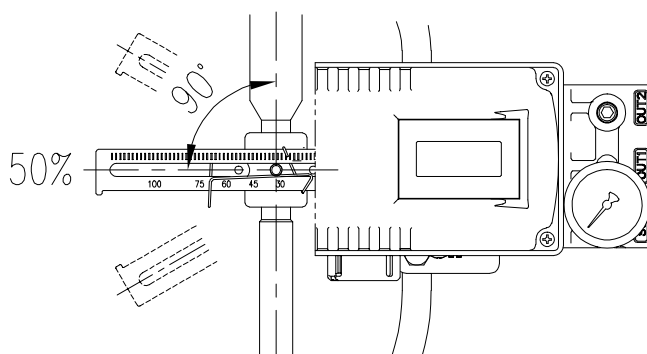

Fig. 3-6: Feedback lever and valve stem

7. Check the valve stroke. The stroke numbers are engraved on the feedback lever of the positioner. Position the connection bar at the number on the feedback lever which corresponds with the desired valve stroke. To adjust, move the bracket, the connection bar or both.

※ The effective linear lever angle is 60 degree.

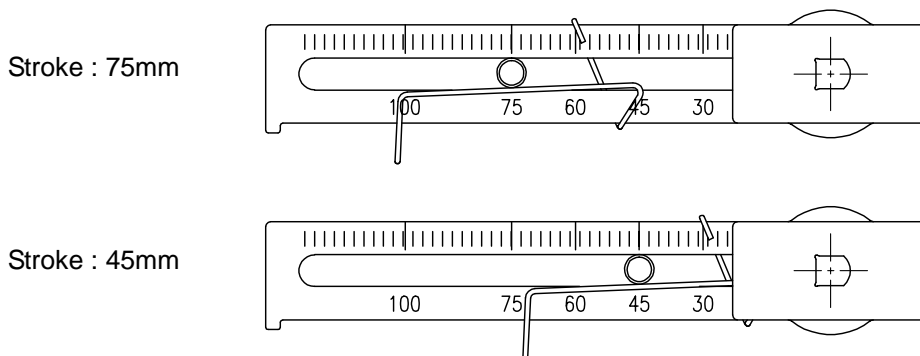

Fig. 3-7: Feedback lever and location of the connection bar



8. After installing the positioner, operate the valve from 0% to 100% stroke by using direct air to the actuator. On both 0% and 100%, the feedback lever should not touch the lever stopper, which is located on the backside of the positioner. If the feedback lever touches the stopper, the positioner should be installed further away from center of the actuator.

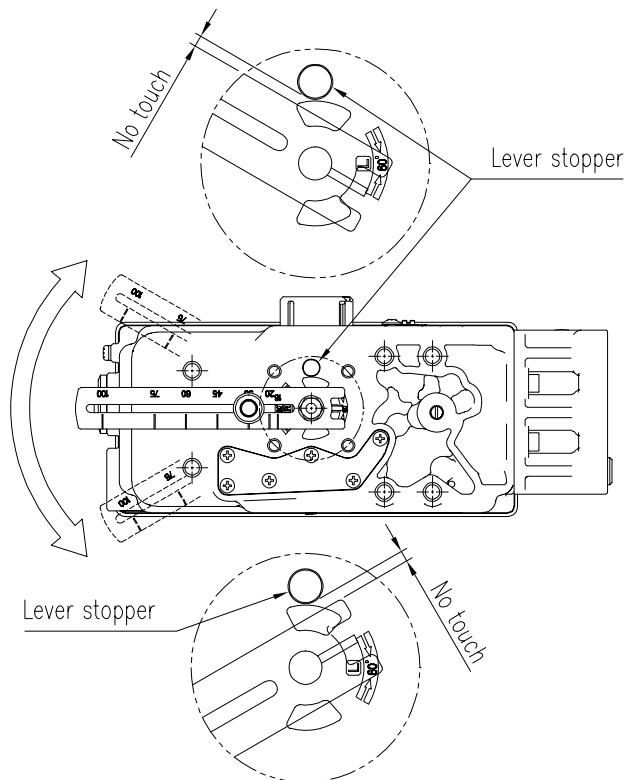

Fig. 3-8: Feedback lever should not touch lever stopper on 0% ~ 100% valve stroke.

9. After the installation, tighten all of the bolts on the bracket and the connection bar.

3.4 Rotary positioner Installation

Rotary positioner should be installed on rotary motion valve such as ball or butterfly type which uses rack and pinion, scotch yoke or other type of actuators which its stem rotates 90 degrees. Before proceeding with the installation, ensure following components are available.

3.4.1 Components

- Positioner
- Rotary bracket set (2 pieces)
- 4 pcs x wrench headed bolts (M6 x 1P x 10L) : For the positioner and the upper bracket
- 4 pcs x wrench headed bolts (M6 x 1P x 15L) : For the brackets
- 4 pcs x M6 nuts : For the brackets
- 4 pcs x M6 spring washers : For the brackets
- Bolts and washers to attach bracket to actuator – not supplied with the positioner

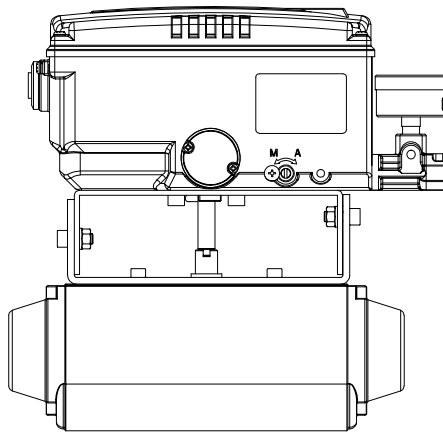

Fig. 3-9: Installation of rotary positioner example

3.4.2 Rotary Bracket Information



The rotary bracket set (included with the positioner) contains two components. The bracket is designed to fit onto the actuator with 20mm, 30mm and 50mm stem height (H) according to VDI/VDE 3845 standard. Please refer to below table how to adjust the height of the bracket.

Actuator stem height (H)	Markings of bolt holes			
	A-L	B-L	A-R	B-R
20mm	H : 20	H : 20, 30	H : 20	H : 20, 30
30mm	H : 30	H : 20, 30	H : 30	H : 20, 30
50mm	H : 50	H : 50	H : 50	H : 50

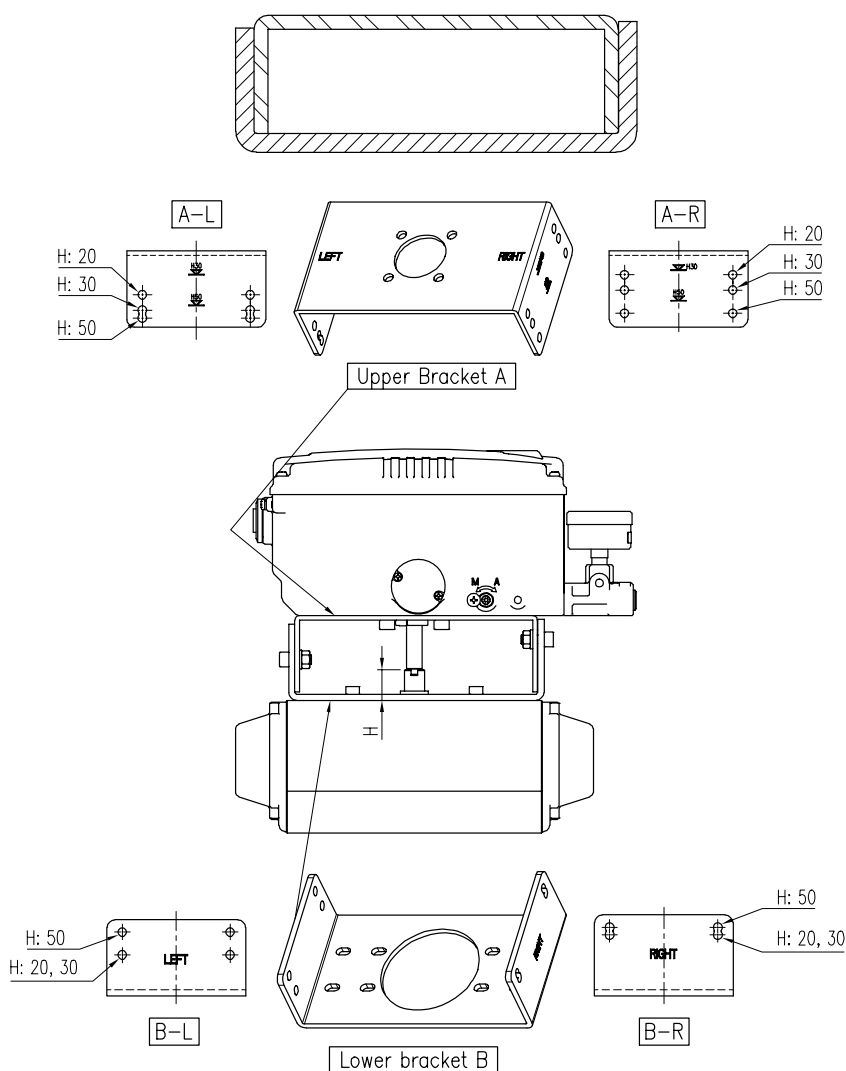

Fig. 3-10: Brackets and positioner

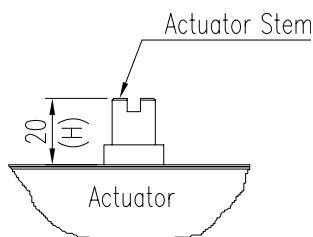

Fig. 3-11: Actuator stem Height

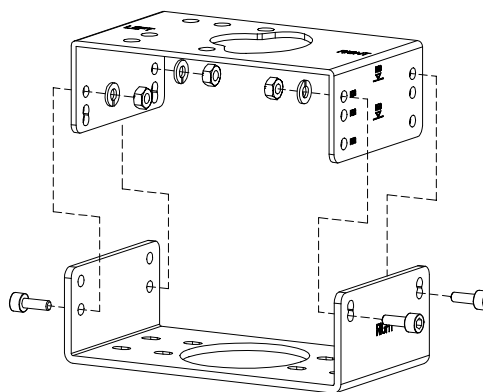

Fig. 3-12: Exploded Brackets

3.4.3 Rotary positioner Installation Steps

1. Please check the actuator's stem height and adjust the brackets by referring to the above bracket table.
2. Attached the brackets onto the actuator. It is recommended to use spring washer so the bolts will not be loosen from vibration.
3. Set rotation position of the actuator stem at 0%. For single acting actuator, it is easy to check 0% point by supplying no pressure to the actuator. For double acting actuator, check actuator stem's rotation direction – clockwise or counter-clockwise - by supplying pressure to the actuator.



4. Attach the positioner to the bracket. Setting alignment of center of main shaft of the positioner and center of the actuator's stem is very important. Poor alignment of the main shaft and the actuator's stem decreases the positioner's durability due to unnecessary forces on the main shaft.

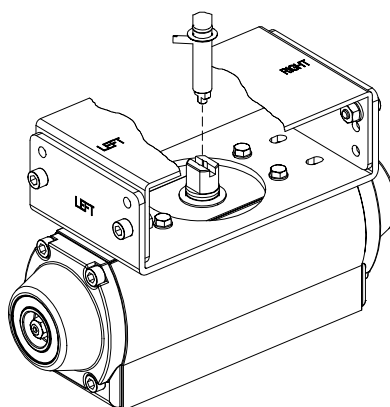

Fig. 3-13: Main shaft center alignment

5. Tighten the positioner and the bracket with bolts **after checking the positioner's position.**

4 Connection - Air

4.1 Safety

- Supply pressure should be clean and dry air – avoiding moisture, oil and dust.
- Always recommended to use air filter regulator (i.e. YT-200 series).
- Rotork YTC Limited **has not tested positioner's operation with any other gases other than clean air. Please contact Rotork YTC Limited for any questions.**

4.2 Supply Pressure Condition



- Dry air with dew point of at least 10°C lower than ambient temperature.
- Avoid from dusty air. Use 5 micron or smaller filter.
- Avoid oil.
- Comply with ISO 8573-1 or ISA 7.0.01.
- Supply pressure range is 0.14 ~0.7 MPa (1.4 ~ 7 bar)
- Set air filter regulator's pressure level 10% higher than actuator's spring range pressure.

4.3 Piping Condition



- Ensure inside of pipe is clean of obstructions.
- Do not use pipeline that is squeezed or shows any type of damages.
- Pipeline should have more than 6mm of inner diameter (10mm outer diameter) to maintain flow rate.
- The length of pipeline system should not be extremely long. Longer pipeline system may affect flow rate due to the friction inside of the pipeline.

4.4 Connection – Piping with actuator

4.4.1 Single acting actuator

Single acting type positioner is set to use only OUT1 port. OUT1 port of positioner should be connected with supply port of actuator when using spring return actuator of single acting type.

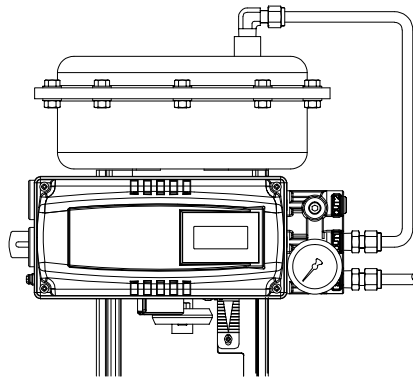

Fig. 4-1: Single acting linear actuator

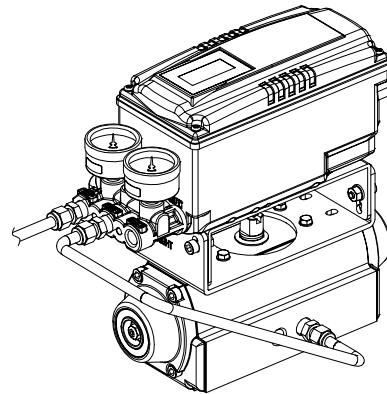

Fig. 4-2: Single acting rotary actuator

4.4.2 Double acting actuator

Double acting type positioner is set to use OUT1 and OUT2 port. As input signal increases, the supply pressure will be supplied through OUT1 port.

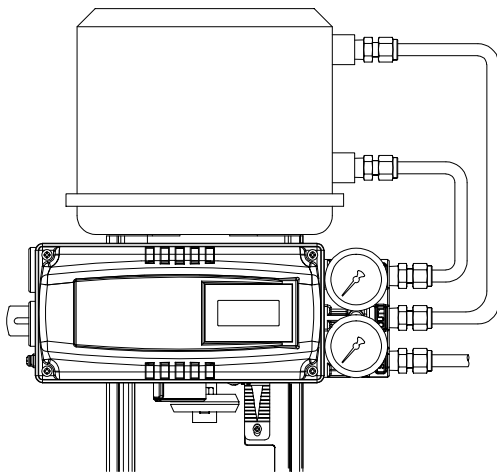

Fig. 4-3: Double acting linear actuator

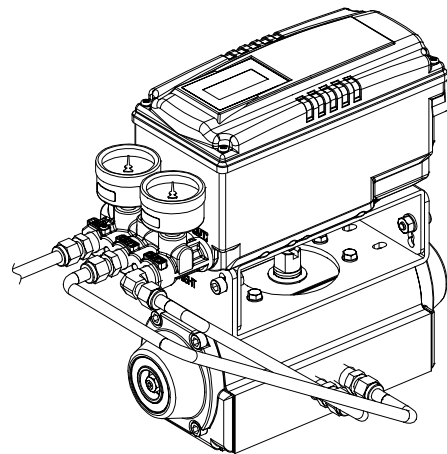

Fig. 4-4: Double acting rotary actuator

5 Connection – Power

5.1 Safety



- There are two conduit entries on the product. See “2.4 Product Code” for conduit entry threads.
- Before connecting terminal, ensure that the power is off completely.
- Please use ring terminal to protect against vibration or any other external impact.
- Positioner usually uses 4~20mA DC. Minimum ampere of input signal is 3.8 mA but maximum ampere of input signal should be 24mA or under.
- Compliance voltage of current source must be Min. 10V and Max. 28V. If the length of the supply cable between the current source and the positioner is long, or if there is a filter or safety barrier, then consider using a current source which could supply higher Compliance voltage.
- Positioner with PTM options must be supplied with **9~28V DC** separately. For mechanical limit switch option, separate **12~30V DC** must be supplied. For inductive proximity limit switch option, separate **8.2V DC** must be supplied.
- DO NOT connect Voltage source (9~28V DC) to Input (4~20mA DC) terminal (IN+, IN-) as it will cause PCB failure.
- Positioner should be grounded.
- Please use twisted cable with conductor section are 1.25mm² and that is suitable for 600V (complying with the conductor table of NEC Article 310). The outer diameter of the cable should be between 6.35 ~ 10mm. Use shield wire to protect against electro-magnetic field and noise.
- Please do not install the cable near high noise equipment, such as high-capacity transformer or motor.
- Please ensure that keep away magnetic materials from a product. It may cause malfunction. For a magnetic screwdriver, It must be away more than 30cm from a product cover.

5.2 Connection

5.2.1 Standard Terminals

The input/output terminals of the basic model are connected to an external system as shown below. Refer to the table below for the signal name and function of each terminal.

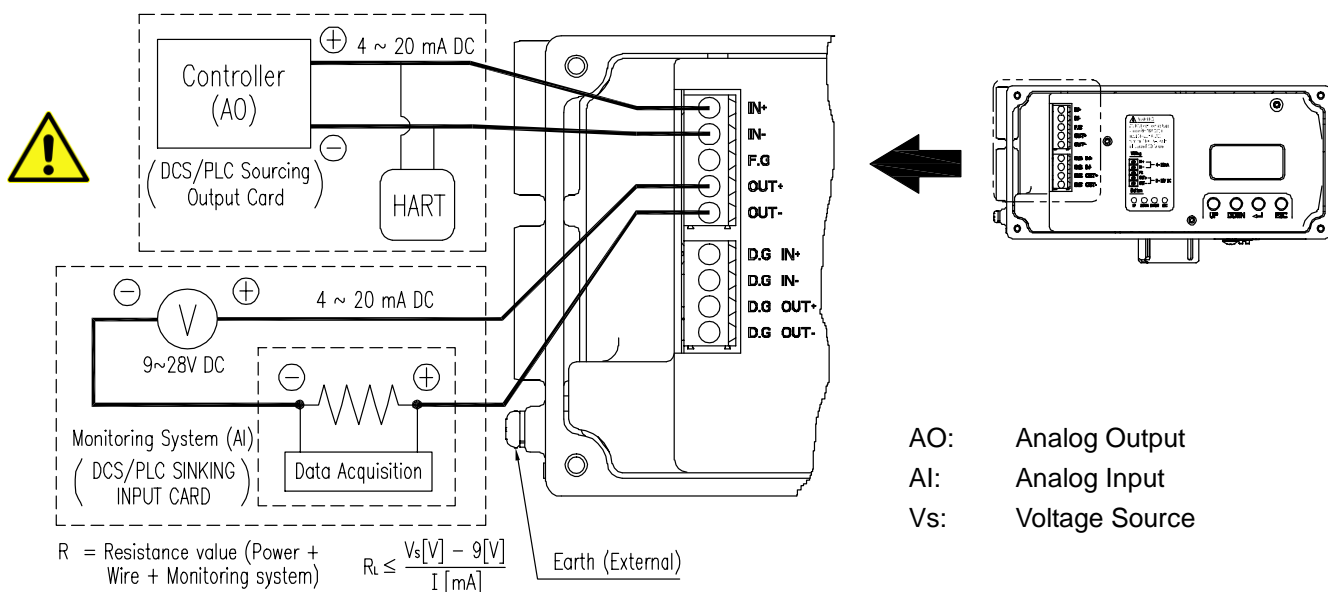

Fig. 5-1: Terminal Overview

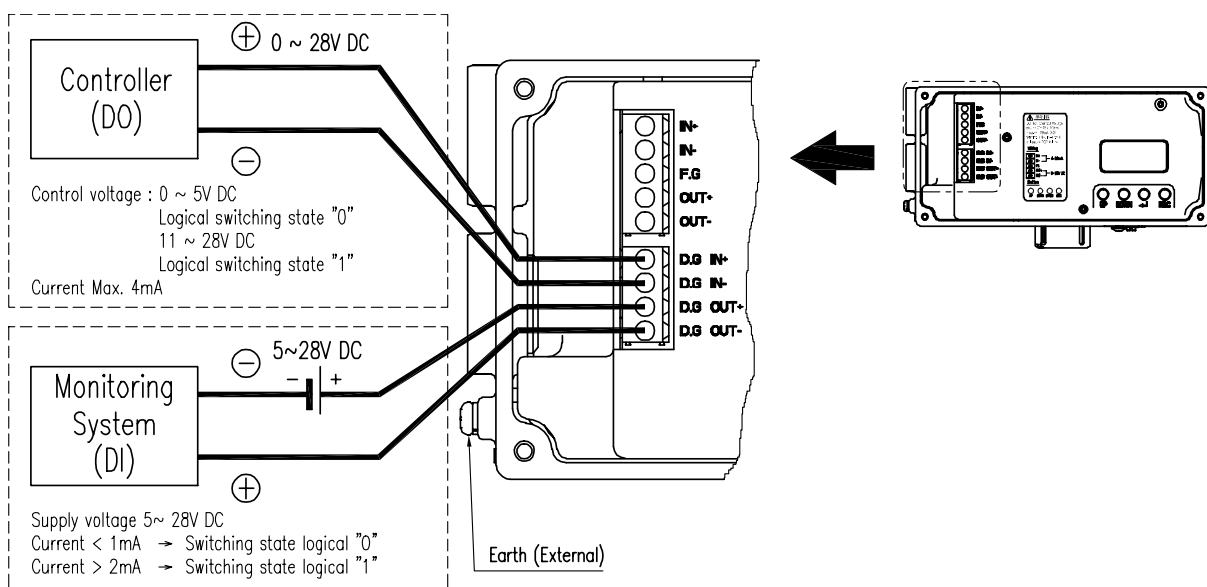

Fig. 5-2: Terminal Overview

Terminal name	Signal name	Function
IN+	Current input signal (+)	Apply analog current command 4 - 20 mA to this terminal to supply power and signal to the positioner.
IN-	Current input signal (-)	
F.G	Safety ground	Safety ground
OUT+	Analog output signal (+)	Analog feedback signal indicating the position of the current valve
OUT-	Analog output signal (-)	
D.G IN+	Digital input signal (+)	A digital input that performs a specific function. The 0 - 5 V input is defined as Low level, and the 10 - 28 V input is defined as High level.
D.G IN-	Digital input signal (-)	
D.G OUT+	Digital output signal (+)	A digital output signal that is activated when a specific event or alarm is triggered. When the output is activated by Low logic at the input voltage range of 5 to 28VDC, no current flows to the output port, and when it is activated by High logic, the current flows between 2.1 and 14.0mA.
D.G OUT-	Digital output signal (-)	

5.2.2 Terminals with micro-limit switch option

The input and output terminals of products equipped with micro-limit switches can be connected to an external system as shown below. Refer to the table below for the signal name and function of each terminal.

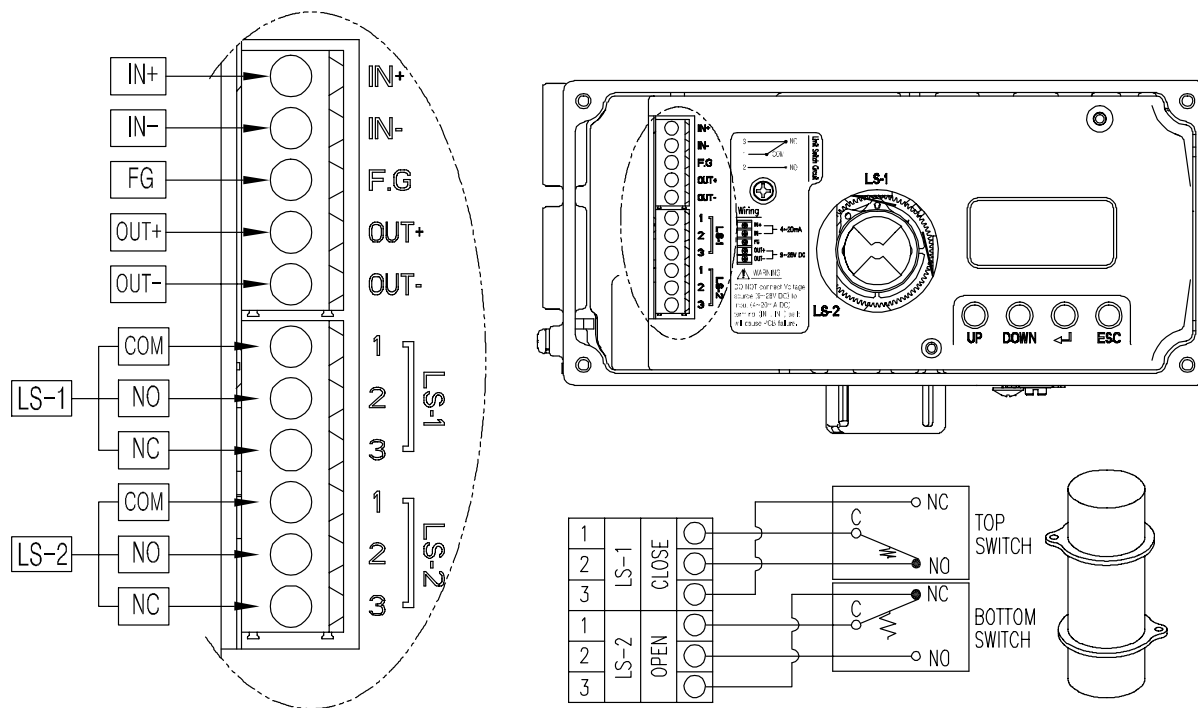

Fig. 5-3: Mechanical Switch Terminal

Terminal name	Signal name	Function
1, LS-1	Common terminal for Limit Switch 1	Common contact terminal for Limit Switch 1
2, LS-1	Normal open signal for Limit Switch 1	The contact of the Limit Switch 1 is closed when the valve passes through the preset position.
3, LS-1	Normal close signal for Limit Switch 1	The contact of the Limit Switch 1 opens when the valve passes through the preset position.
1, LS-2	Common terminal for Limit Switch 2	Common contact terminal for Limit Switch 2
2, LS-2	Normal open signal for Limit Switch 2	The contact of the Limit Switch 2 is closed when the valve passes through the preset position.
3, LS-2	Normal close signal for Limit Switch 2	The contact of the Limit Switch 2 opens when the valve passes through the preset position.

5.2.3 Terminals with proximity Limit Switch option

The input and output terminals of products equipped with proximity limit switch switches can be connected to an external system as shown below. Refer to the table below for the signal name and function of each terminal.

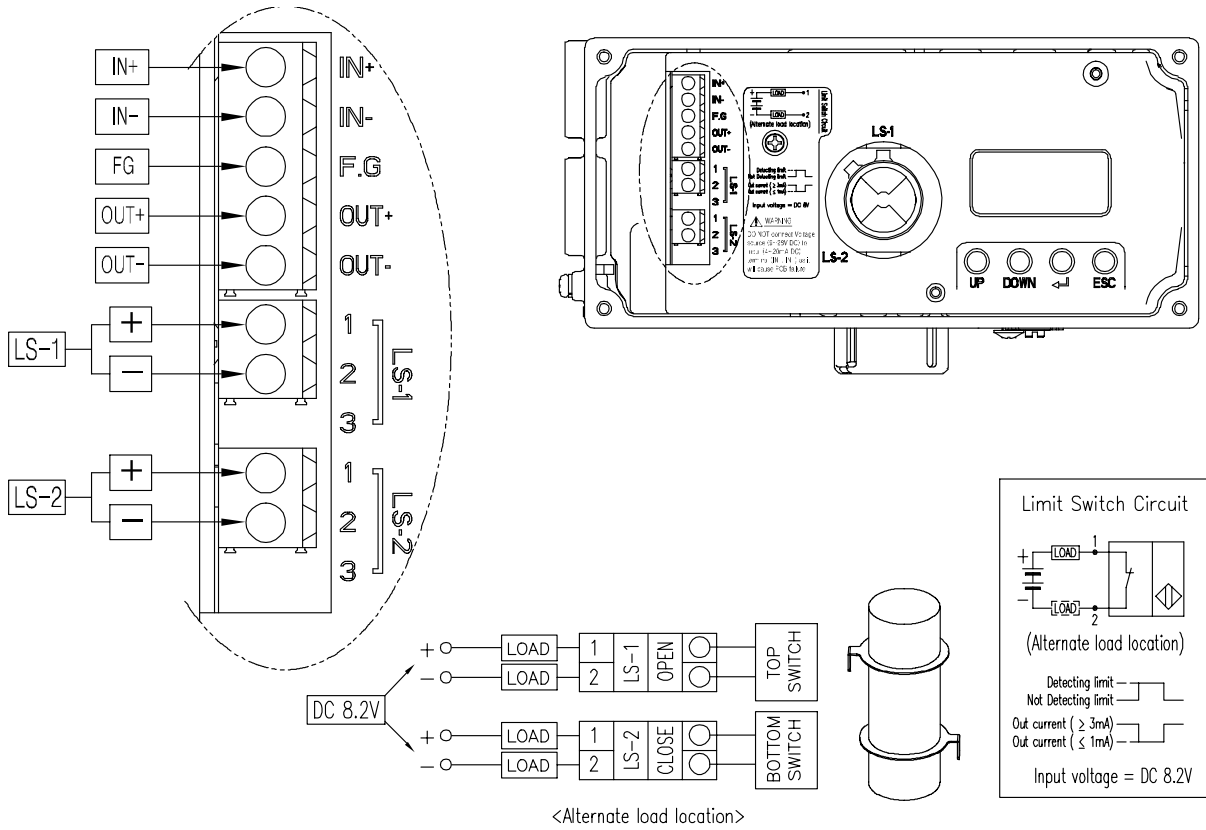

Fig. 5-4: Proximity Sensor Switch Terminal

Terminal name	Signal name	Function
1, LS-1	Common terminal for Limit Switch 1	Common contact terminal for Limit Switch 1
2, LS-1	Normal open signal for Limit Switch 1	The contact of the Limit Switch 1 is closed when the valve passes through the preset position.
3, LS-1	No connection	Not used
1, LS-2	Common terminal for Limit Switch 2	Common contact terminal for Limit Switch 2
2, LS-2	Normal close signal for Limit Switch 2	The contact of the Limit Switch 1 opens when the valve passes through the preset position.
3, LS-2	No connection	Not used

5.3 Ground

1. Ground must be done before operating the positioner.
2. Open base cover and there is an internal ground "F.G" on the left hand.

An external ground bolt is located next to the conduit entry. Please make sure that the resistance is less than 100 ohm.

6 Adjustments

6.1 Limit Switch Adjustment

YT-3700 / 3750 can have limit switch option. If user wants to adjust the sensing position, please loosen bolts and adjust cam.

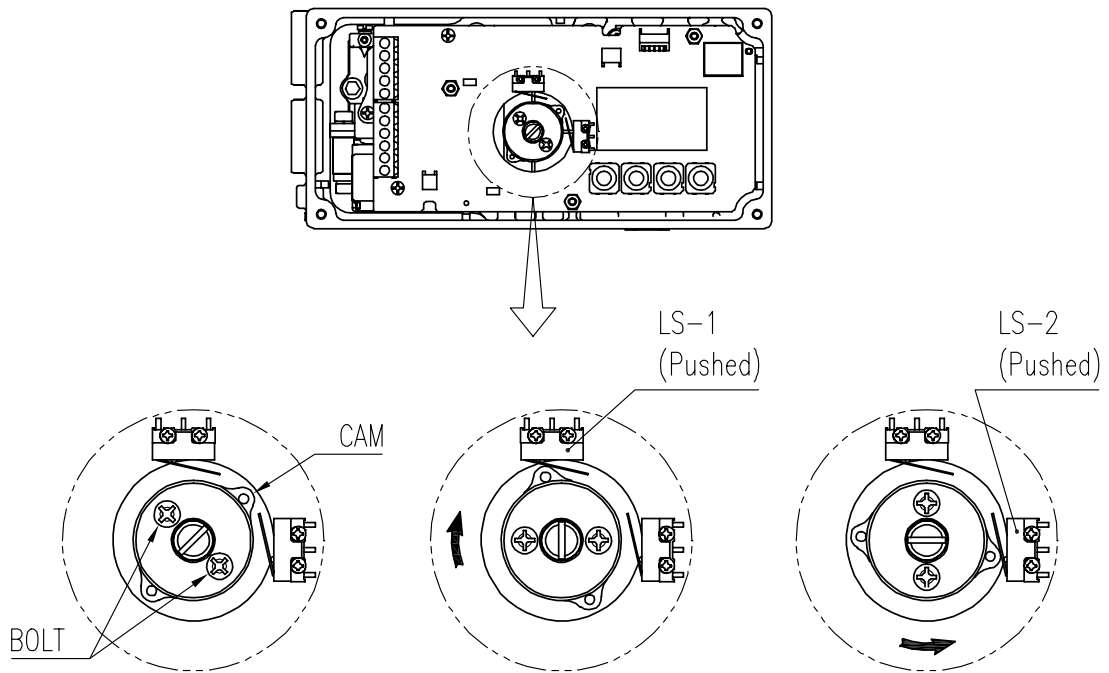

Fig. 6-1: Mechanical Type

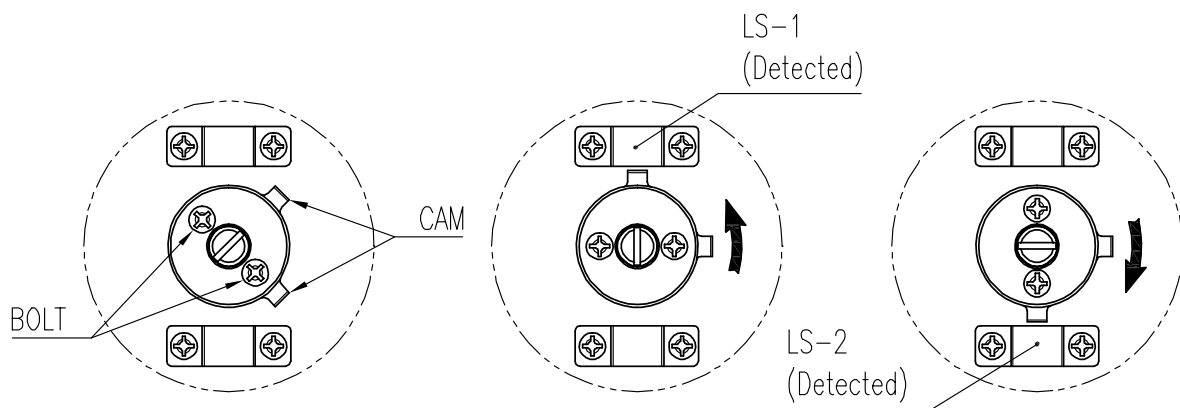

Fig. 6-2: Proximity Type

6.2 A/M switch adjustment

1. On the right hand bottom of positioner, there is A/M switch (Auto/Manual). A/M Switch allows the positioner to be functioned as by-pass. If the switch is turned clockwise (toward “A”) and it is fasten tightly, then the supply pressure will be transferred to actuator through output port by positioner control. On the other hand, if the switch is turned counter-clockwise (toward “M”), it is loosened, then the supply pressure will be directly supplied to the actuator regardless of positioner control. It is extremely important to check the allowed pressure level of the actuator when the switch is loosened.
2. Check whether the supply pressure is too high.
3. After using “Manual” function, A/M switch should be returned to “Auto”.

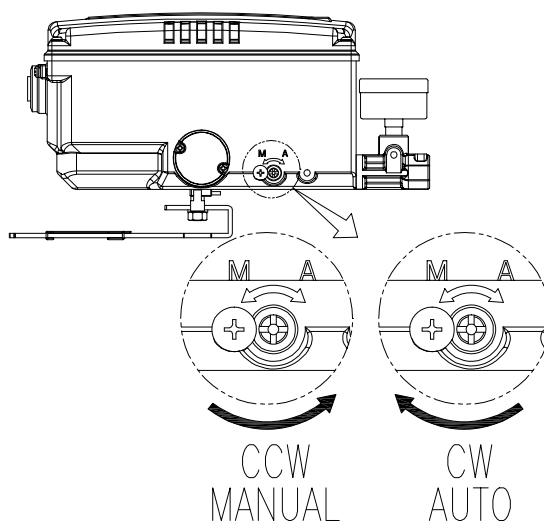

Fig. 6-3: A/M switch adjustment

6.3 Orifice Installment

Hunting can be occurred when the actuator's volume is too small. In order to prevent hunting, orifice can be used.

6.3.1 Plate type Orifice Installment

By installing the plate type orifice, the flow rate of the supply pressure to actuator can be reduced. The diameter of orifice hole is 1 mm.

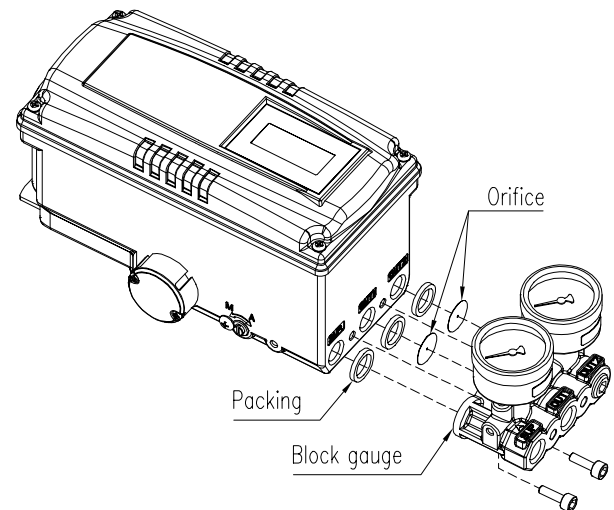

Fig. 6-4: Plate type Orifice installment

7 Optional Sub-PCB Installment

By adding sub-PCB, the positioner can have additional functions. There are 3 types of sub-PCB.

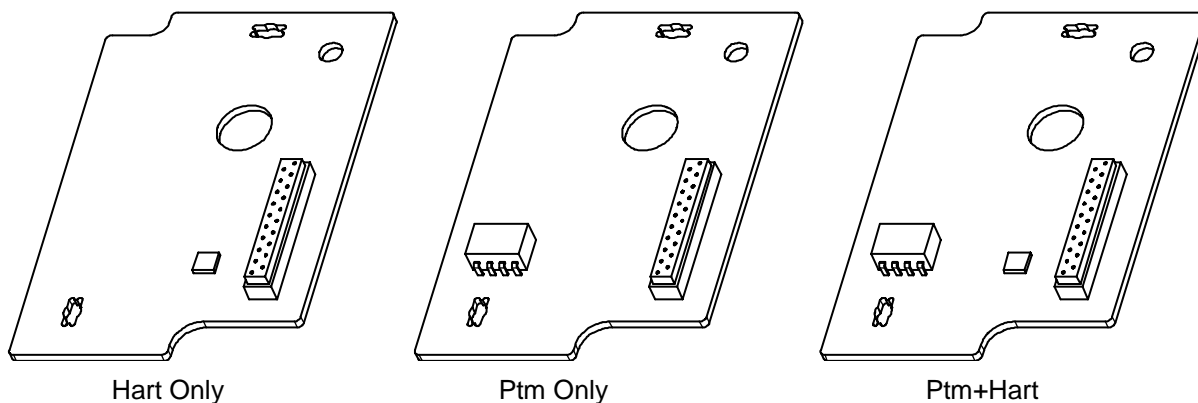

Fig. 7-1: Three types of Sub-PCB of YT-3700 / 3701 / 3703 / 3750

When purchasing option sub-PCBs separately, 4 Bolts and 2 supports are supplied together with sub-PCB.

7.1 Installation steps

1. Mount 2ea of sub-PCB support on sub-PCB with 2ea of bolt.
2. Open base cover, PCB cover. Separate the Main PCB from base body.
3. Insert connector of sub-PCB into connector of main PCB correctly.
4. Fasten sub-PCB with the rest of bolt 2ea.

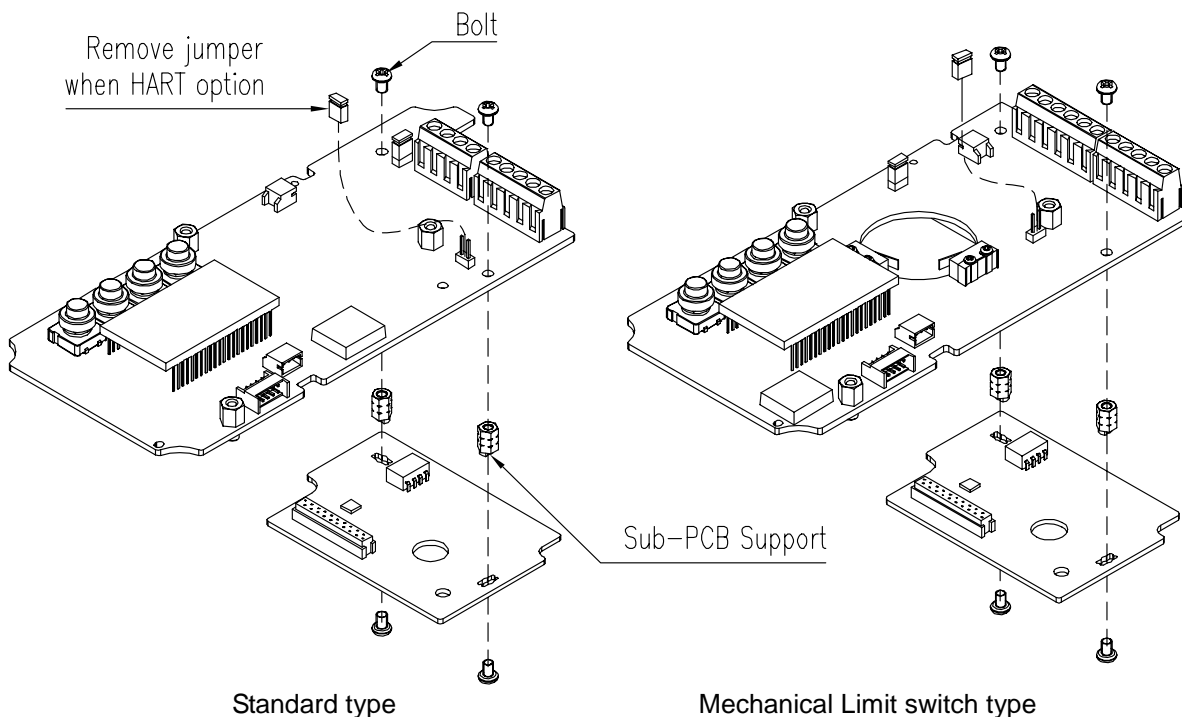
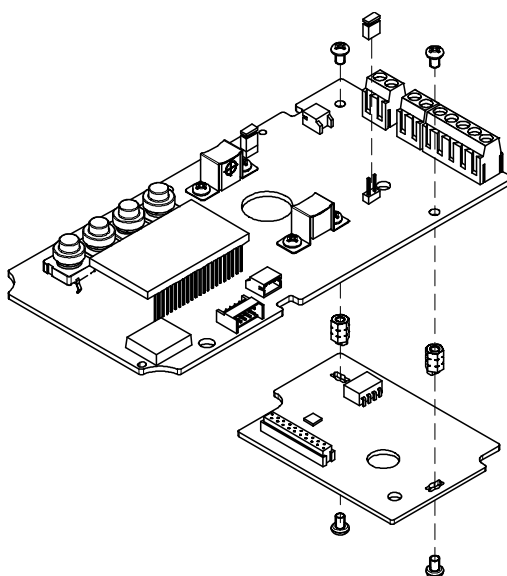

Fig. 7-2: Installation of Option PCB on Main PCBs



Proximity Limit switch type

Fig. 7-3: Installation of Option PCB on Main PCBs



JP1 jumper must be removed, when HART option included sub-PCB is being mounted.

5. After PTM sub-PCB is installed newly, values of PTM ZERO and PTM ENd must be calibrated for correct output signals. For the calibration of PTM ZERO and PTM ENd, please refer to section 8.10.2 of this manual.

8 Auto Calibration and PCB Operation

8.1 Warning



Following process will operate valve and actuator. Make sure to disconnect the Valve from the system prior to the automatic calibration (AutoCal) to prevent any disruption of the process since this operation shall move the Valve and Actuator.

8.2 LCD display and buttons

8.2.1 LCD display and symbols

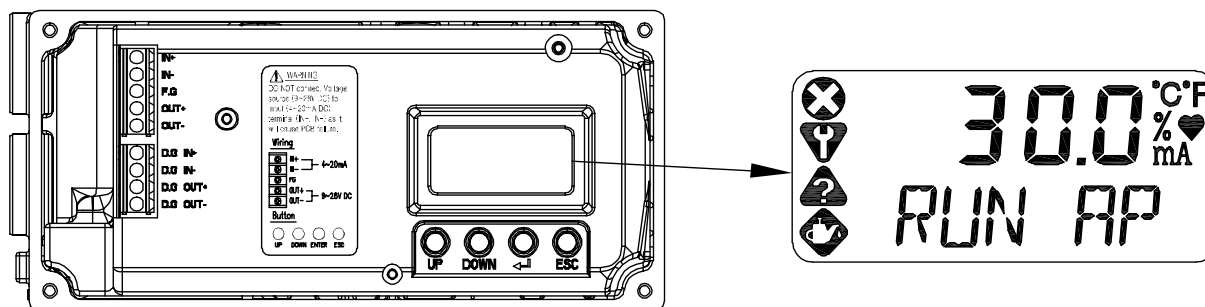

Fig. 8-1

NE107 Symbols	Description	Symbols	Description
	Failure	°C	Degree in Celsius
	Functional Check	°F	Degree in Fahrenheit
	Out of Specifications	%	Percent
	Maintenance Required	♥	Communication status
		mA	Current in mA

The four symbols located on the left are the symbols that display alarm messages classified in four groups in accordance with NAMUR NE107. Assigning each alarm to a specific group of four groups can only be performed through EDD or DTM.

8.2.2 Button and function

Positioner has 4 buttons, and they enable to perform various functions.

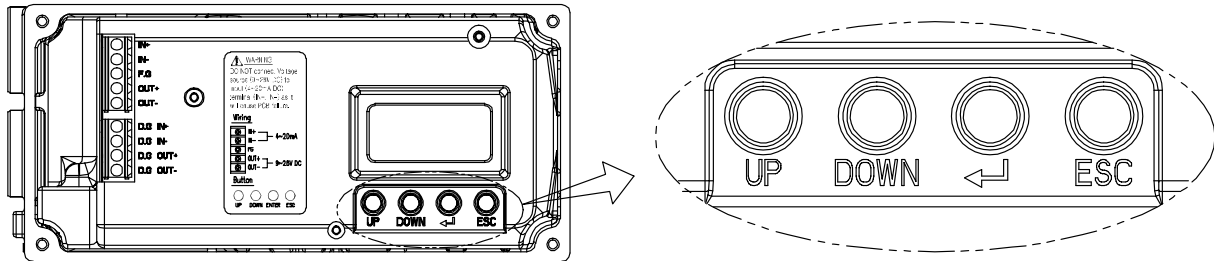
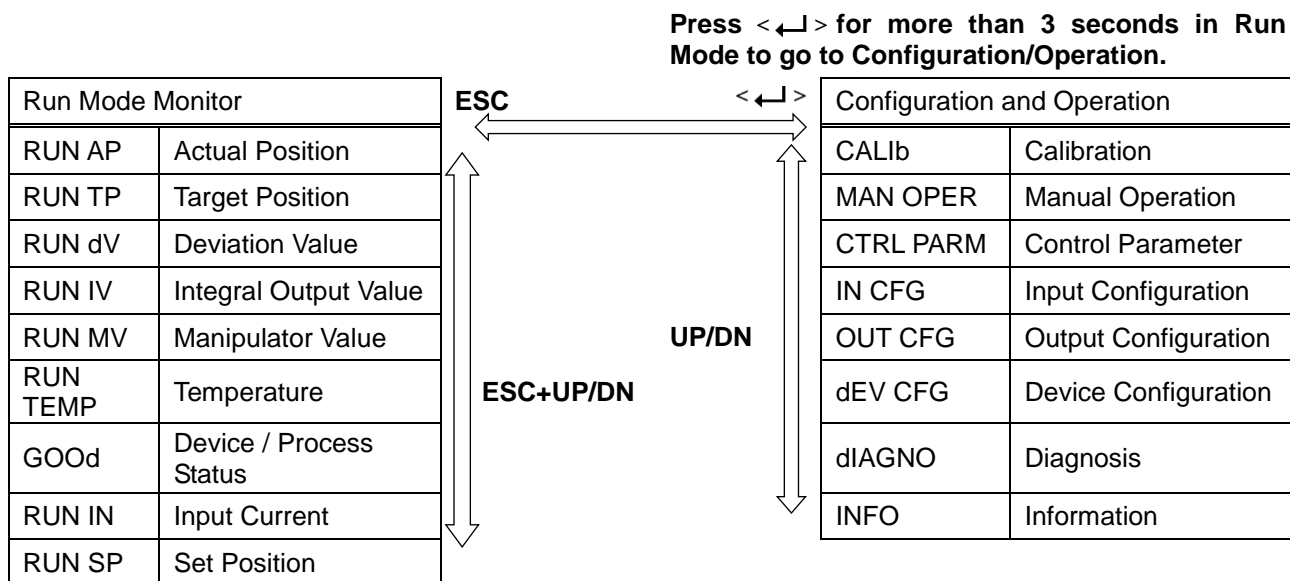

Fig. 8-2

Buttons	Function
UP	Used to navigate to each menu at the same level or to increase the value of the selected parameter.
DOWN	Used to navigate to each menu at the same level in reverse order of UP button or to decrease the value of the selected parameter.
<←→> ENTER	Use to select the current menu or function, or to store the value of a modified parameter.
ESC	Used go directly to parent menu from current menu.

8.3 Menu levels

The basic menu structure consists of the RUN Mode Monitor and the Configuration/Operation. The Run Mode Monitor menu allows you to monitor the values of various variables. The Configuration/Operation menu provides calibration and tuning, manual operation, configuration of I/O port function, configuration and self-test of positioner, configuration of diagnostic function, and basic information of the positioner. See below for information on how to move between Run Mode Monitor menu and Configuration/Operation menu, and move within Run Mode Monitor menu.



Press the <↵> button to select the lower menu of the Configuration/Operation menu. Press the ESC button to return to parent menu after completing configuration. Pressing the ESC button anywhere in the menu structure several times returns the user to the uppermost menu, Run Mode Monitor menu.

8.4 RUN Mode Monitor

The RUN Mode Monitor is displayed on the LCD display when power is provided to the positioner. Pressing the UP/DOWN button scrolls through the various process variables shown in table below. A "30.0%" in the LCD display below indicates that the valve is in the 30% position, and an "AP" indicates the abbreviation of "Actual Position".



The status variables displayed in the RUN Mode Monitor are divided into nine types as shown below.

On LCD	Name	Description
RUN AP [%]	Actual Position	Actual position of the valve indicated as %.
RUN TP [%]	Target Position	Target position in %
RUN dV [%]	Deviation Value	Deviation between target position and actual position.
RUN IV	Integral Output Value	Accumulated integral output value
RUN MV	Manipulator Value	Digital input value applied to I/P converter
RUN TEMP[°C]	Temperature	Internal temperature of positioner in °C.
** dS XXXX (PS XXXX)	** : Alarm Code dS: Device Status PS: Process Status XXXX: NE107 or Abbreviation of each alarm	The status of the current process or positioner is shown with English letter XXXX. Normally, GOOD is displayed when there is no problem, but alarm or status is displayed in abbreviated words (MNTR, FAIL, OUTS, FUNC and so on) along with NE107 symbol when a state change or alarm occurs. Any of the alarms is displayed alternately each time the ENTER button is pressed. (See 8.14 Status and Alarm Code)
RUN IN [mA]	Input Current	Current input signal in mA
RUN SP [%]	Set Position	Input signal converted into %

Normal condition LCD display.



When the condition changed or alarm occurred.

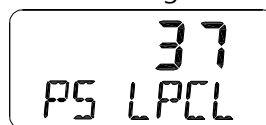

Explaining contents of alarm display

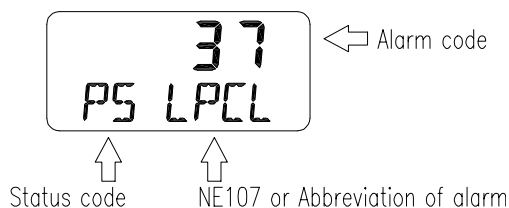

8.5 Configuration and Operation

The Table below shows the eight Configuration/Operation menus, each submenu, ranges for each parameter, and initial factory settings. The words shown in [] for each menu represent the abbreviations of each word displayed when operating the LCD screen.

Level 1	Level 2	Range	Initial factory setting
Calibration [CALIB]	Acting Type	[SINGLE, dOUBLE]	
	Auto Calibration 1 [AUTO 1]		
	Auto Calibration 2 [AUTO 2]		
	Travel Zero [TVL ZERO]		
	Travel End [TVL END]		
Manual Operation [MAN OPER]	Manual Operation by Set Position [MAN SP]		
	Manual Operation by Manipulator Value [MAN MV]		
Control Parameters [CTL PARM]	Dead Band [dEAdbAND]	0.1 ~ 10.0 [%]	0.3 %
	Proportional Gain, Upward [KP UP]	0.1 ~ 50.0	1
	Proportional Gain, Downward [KP dN]	0.1 ~ 50.0	1
	Integral Gain, Upward [TI UP]	0.1 ~ 50.0	1
	Integral Gain, Downward [TI dN]	0.1 ~ 50.0	1
	Differential Gain, Upward [Kd UP]	0.1 ~ 50.0	1
	Differential Gain, Downward [Kd dN]	0.1 ~ 50.0	1
	Auto Dead Band Mode [AUTO db]	oFF, [0%]	oFF
	Performance Mode [PER]	Stable, Normal, Fast [STbL, NORM, FAST]	NORM
Input Configuration [IN CFG]	Signal Direction [SIG]	Normal, Reverse [NORM, REVS]	NORM
	Split Range Mode [SPLIT]	4 ~ 20, 4 ~ 12, 12 ~ 20, Custom [4.20, 4.12, 12.20, CSt]	4.20
	Custom Split Range Zero [CST ZERO]	4 ~ 20.0[mA]	4mA
	Custom Split Range End [CST END]	4 ~ 20.0[mA]	20mA

Level 1	Level 2	Range	Initial factory setting
Input Configuration [IN CFG]	Characterization [CHAR]	Linear, Quick Open, Equal Percent, User Set 5point, User Set 21point [LIN, QO, EQ, U5, U21]	LIN
	User Set Characterization 5p [USER 5P]		0%, 25%, 50%, 75%, 100%
	User Set Characterization 21p [USER 21P]		0%, 5%, 10%, ... 95%, 100%
	Tight Shut Open [TSHUT OP]	0.1 ~ 100 [%]	100.0 %
	Tight Shut Close [TSHUT CL]	0.1 ~ 100 [%]	0.3 %
	SP Ramp Up rate [RAMP UP]	oFF, 0.1 ~ 100 [%]	oFF
	SP Ramp Down rate [RAMP dN]	oFF, 0.1 ~ 100 [%]	oFF
	Digital Input Function [dIF]	[oFF, FCL, FOP, PSTA, PSTO]	oFF
	Digital Input Logic [dI LOGIC]	[Lo, HI]	HI
Output Configuration [OUT CFG]	Position Transmitter Direction [PTM]	[NORM, REVS]	NORM
	Position Transmitter Zero [PTM ZERO]	0 ~ 100.00 [%]	
	Position Transmitter End [PTM ENd]	0 ~ 100.00 [%]	
	HART Feedback Direction [HT]	[NORM, REVS]	NORM
	Back Calculation [bACKCAL]	[oFF, on]	oFF
	Digital Output Function [dOF]	[OFF, TMPH, TMPL, TVLH, TVLL, DVTO, PSTF, LPCL, FAIL, FUNC, OUTS, MNTR]	OFF
	Digital Output Logic [dO LOGIC]	[Lo, HI]	HI
	Analog Output Function [AOF]	[OFF, TMPH, TMPL, TVLH, TVLL, DVTO, PSTF, LPCL, FAIL, FUNC, OUTS, MNTR]	OFF
	AO Current for Alarm Function [AO LOGIC]	[Lo, HI]	LO
Device Configuration [dEV CFG]	Action Change [ACT]	[dIR, REVS]	REVS
	Linear Interpolation [ITP]	[oFF, on]	on with Linear oFF with Rotary
	Write Protect [W]	[UNLOCK, LOCK]	UNLOCK
	View Mode [VI]	[NORM, REVS]	NORM
	Polling Address [POL AddrR]	[0 ~ 63]	0
	Factory Reset [dEFAULT]		
	Self-Test [SELFTEST]		

Level 1	Level 2	Range	Initial factory setting
Diagnosis [dIAGNO]	Process Status [PS]	GOOd, FAIL, FUNC, OUTS, MNTR	GOOd
	Device Status [dS]	GOOd, Refer to 8.14 Status and Alarm Code.	GOOd
	View Monitoring Counts [VI CNTS]	[CYCL CNT, TVLACUM, OPER CNT, FOP CNT, FCL CNT]	0
	Diagnosis Limit Configuration [LIMIT CFG]	TVL HI, TVL LO, TEMP HI, TEMP LO, dV TIME, dV db, AL TVLH, AL TVLL, AL TMPH, AL TMPL, AL dVTO	100%, 0%, 85°C -30°C (depending on option) 10sec, 5.0%, oFF, oFF, oFF, oFF, on
	Reset Alarm Status [RST ALRM]		
	View Event Log [EVT LOG]	RECORD 0 - 19	1
	View PST Result Record [PST RSLT]	RECORD 0 - 11	1
	PST Configuration [PST CFG]	INTERVAL, START PO, TOL, TARGET, HOLD TM, LIMIT TM, PRAMP UP, PRAMP dN, NEXT PST	365d, 100%, 5%, 90%, 5sec, 10sec, 0%, 0%, oFF
	Run PST [PST NOW]		
	PST Schedule [PST SCHd]	on, oFF	oFF
	Information [INFO]	Model Name [YT3700*]	
Firmware Version [SOFT VER]		*.*.**	Program current version
Download Date		YYYYMMDD	Program input date
Run Time [RT]		*.*. RT *d	
Upward Stroke Time [FULL OP]		*.*.*	
Downward Stroke Time [FULL CL]		*.*.*	
Position Sensor Type [PSNT]		PTN, NCS	
Absolute Position in Angle [AbS ANGL]		*.*.*°	
HART Protocol Revision [HART VER]	7	7	

The Table below identifies the range and initial factory settings of each parameter for Menu Level 2 and Menu Level 3 where the menu hierarchy has been lowered by one level.

Level 2	Level 3	Range	Initial factory setting
View Monitoring Counts [VI CNTS]	Cycle Count [CYCL CNT]	0 ~ 4,200,000,000	
	Accumulated Travel [TVL ACUM]	0 ~ 168,000,000 [%]	
	Operating Count [OPER CNT]	0 ~ 4,200,000,000	
	Full Open Count [FOP CNT]	0 ~ 4,200,000,000	
	Full Close Count [FCL CNT]	0 ~ 4,200,000,000	
LIMT CFG	Travel Hi Limit [TVL HI]	0 ~ 120 [%]	100 %
	Travel Lo Limit [TVL LO]	-10 ~ 50 [%]	0 %
	Temperature Hi Limit [TEMP HI]	-57 ~ 85 [°C]	Selecting by temp. option
	Temperature Lo Limit [TEMP LO]	-57 ~ 85 [°C]	Selecting by temp. option
	Deviation Time [dV TIME]	0 ~ 300 [sec]	60 sec
	Deviation Deadband [dV db]	0 ~ 10 [%]	5 %
	Travel Hi Limit Alarm Enable [AL TVLH]	oFF, on	oFF
	Travel Lo Limit Alarm Enable [AL TVLL]	oFF, on	oFF
	Temperature Hi Limit Alarm Enable [AL TMPH]	oFF, on	oFF
	Temperature Lo Limit Alarm Enable [AL TMPL]	oFF, on	oFF
	Deviation Time Out Alarm Enable [AL dVTO]	oFF, on	oFF
PST CFG	PST Interval [INTERVAL]	1 ~ 365 [days]	365
	PST Starting Position [START PO]	0 ~ 100 [%]	100 %
	PST Tolerance [TOL]	0.1 ~ 10 [%]	5 %
	PST Target Position [TARGET]	0 ~ 100 [%]	90 %
	PST Hold Time [HOLD TM]	1 ~ 300 [sec]	5 sec
	PST Limit Time [LIMT TM]	1 ~ 200 [sec]	10 sec
	PST Ramp Up Rate [PRAMP UP]	oFF, 1 ~ 100 [%/sec]	oFF
	PST Ramp Down Rate [PRAMP dN]	oFF, 1 ~ 100 [%/sec]	oFF
	PST Time Remaining [NEXT PST]	oFF, 1 ~ 365[days], 0 ~ 24[hour]	oFF

8.6 Calibration (CALib)

The calibration consists of five menus.

Calibration [CALib]	Acting Type [SINGLE/ dOUBLE]	Set manually single or double acting by actuator type
	Auto Calibration 1 [AUTO 1]	Calibration on the zero and end points of the valve
	Auto Calibration 2 [AUTO 2]	Calibration on all parameters required to operate the valve
	Travel Zero [TVL ZERO]	Manually adjust the zero point of the valve
	Travel End [TVL END]	Manually adjust the endpoint of the valve

Auto Calibration simplifies calibration without having to go through complex gain tuning. Once the current input between 4 and 20 mA is applied, it takes approximately 2-3 minutes to complete the automatic calibration, which may vary depending on the size of the actuator. There are two types of Auto Calibrations as shown below so that you select and use them as required.

	ZERO	END	P, I, D gain	RA, DA	BIAS
AUTO 1	√	√			
AUTO 2	√	√	√	√	√

8.6.1 Acting Type (SINGLE / dDOUBLE)

This is used to change the settings of the positioner to SINGLE or dDOUBLE, depending on the actuator type. The setting of the SINGLE and dDOUBLE affects the automatic calibration, so it must be set carefully considering the actuator type.



When the actual acting types of Actuator is different with the setting values, make sure to fit the actual acting type with the currently operating Actuator type as it causes any problems.

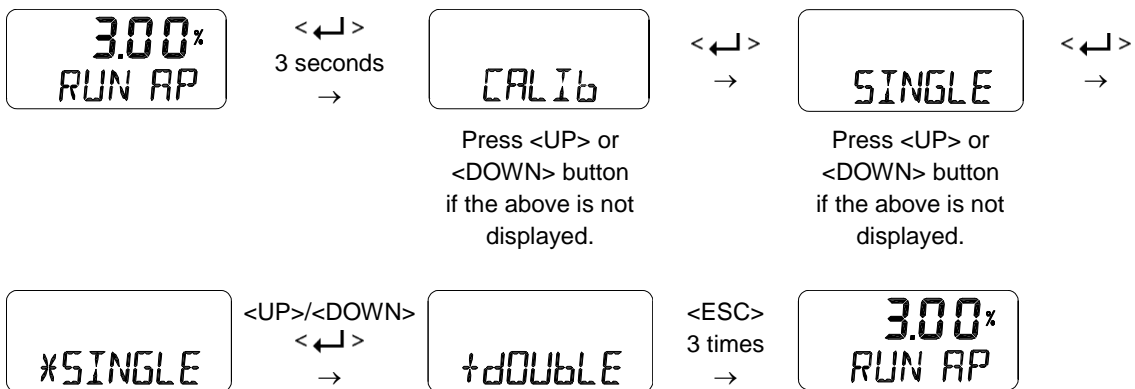

8.6.2 Auto Calibration 1 (AUTO 1)

AUTO 1 is used to set only the origin and end points. It does not change the PID and other parameter values that already have been set. This is usually used when the origin and end points of the already calibrated positioner have changed slightly.

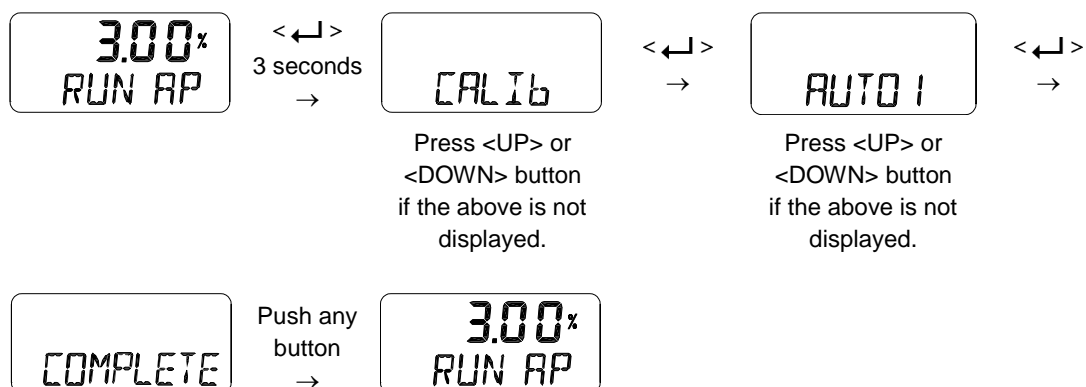

8.6.3 Auto Calibration 2 (AUTO 2)

AUTO 2 tunes up and then changes all parameters required for valve operation. Be sure to perform this AUTO 2 when installing the positioner on the valve for the first time or when reinstalling the positioner from the actuator.

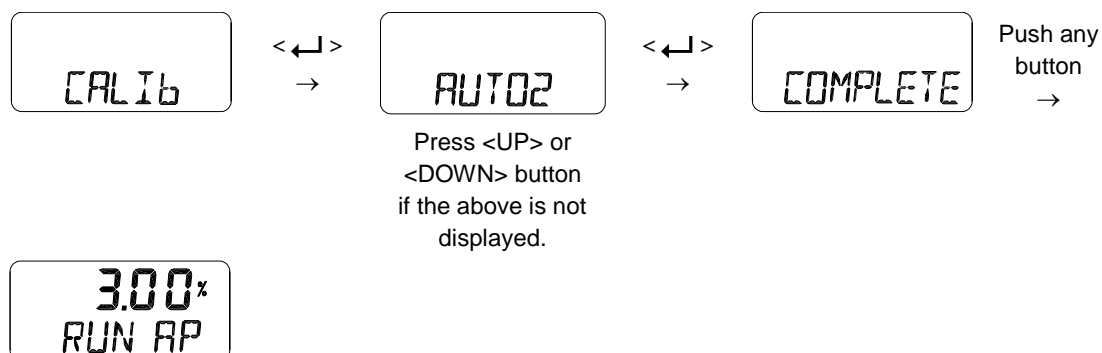

8.6.4 Travel Zero (TVL ZERO) and Travel end (TVL END)

This is a manual adjustment of the zero point or endpoint of the valve after auto calibration. Once you enter the TRAVEL ZERO (or TRAVE END) setting, press the UP/DOWN button to change the zero point (or endpoint) of the valve, and then press the ENTER button to save it. The saved position is recognized as the zero (or endpoint) of the valve.

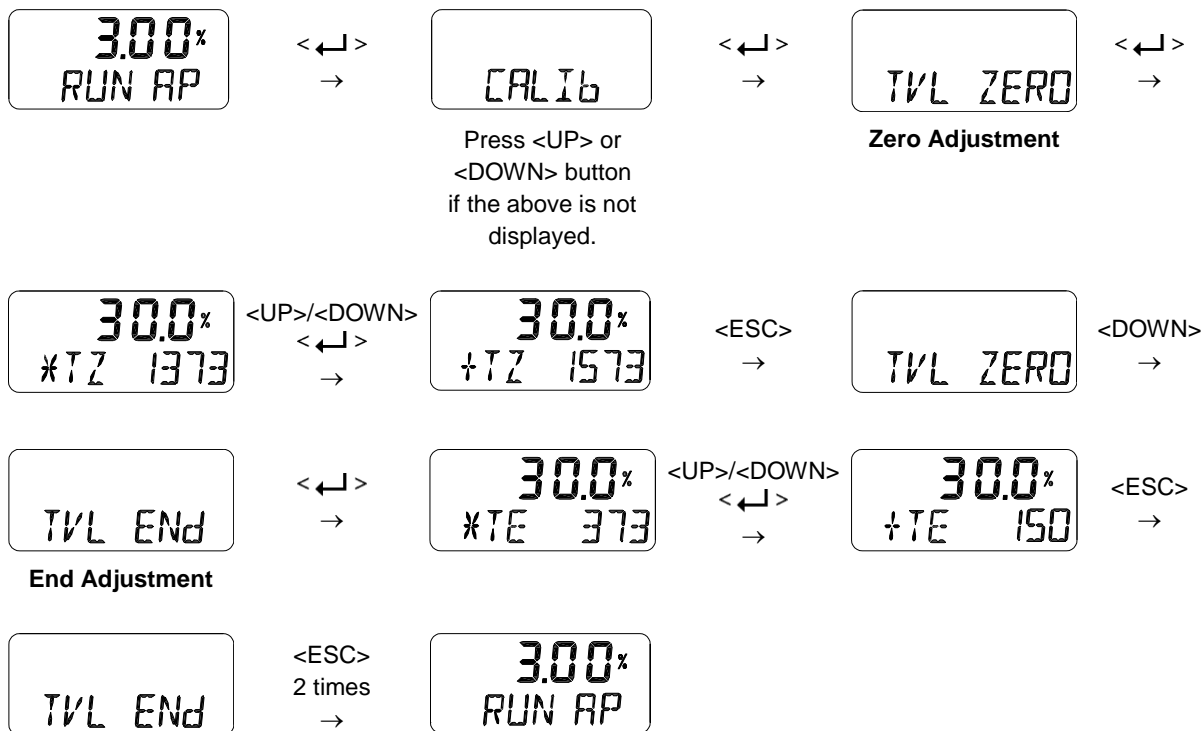

8.7 Manual Operation (MAN OPER)

It is used to manually raise or lower the valve stem by operating the UP or DOWN buttons. This can be used to observe the move of valve stem without any external input signals. When engaged, the current input signal to the positioner has no effect on the positioner.



Manual operation may affect the process in service, so use this function when the process is down or when it is acceptable to shut down the process.

8.7.1 Manual Operation by Set position (MAN SP)

The target position is incremented by the UP and DOWN buttons based on the currently entered set position values, which moves the stem of the valve up and down. Once out of the menu by <ESC>, the positioner is controlled again by an input signal.

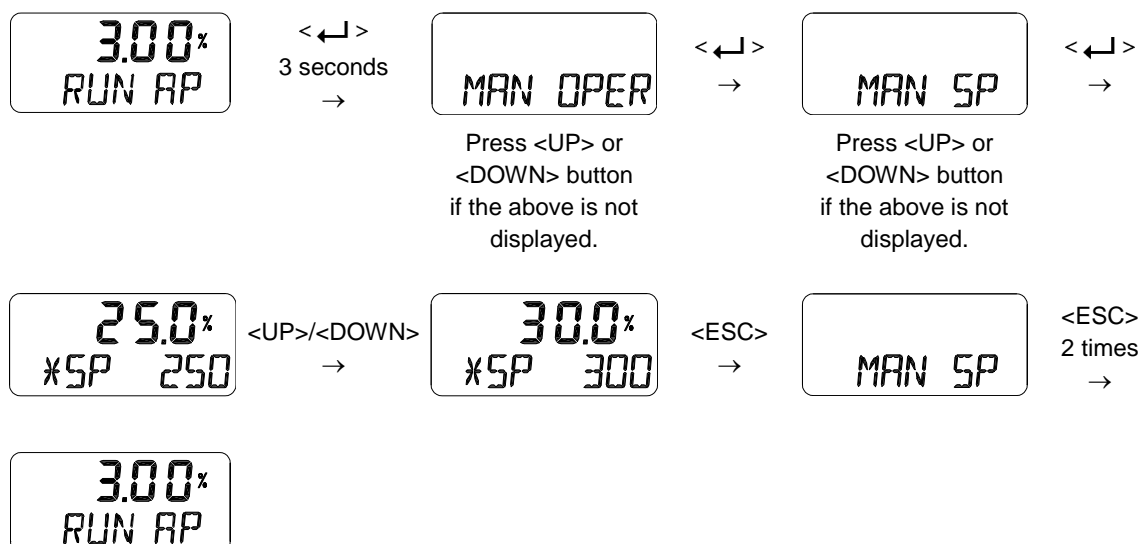

8.7.2 Manual Operation by MV (MAN MV)

The input to I/P converter is incremented or decremented by the UP and DOWN buttons based on the currently entered I/P input value, which moves the stem of the valve up and down. Once out of the menu by <ESC>, the positioner is controlled again by an input signal.

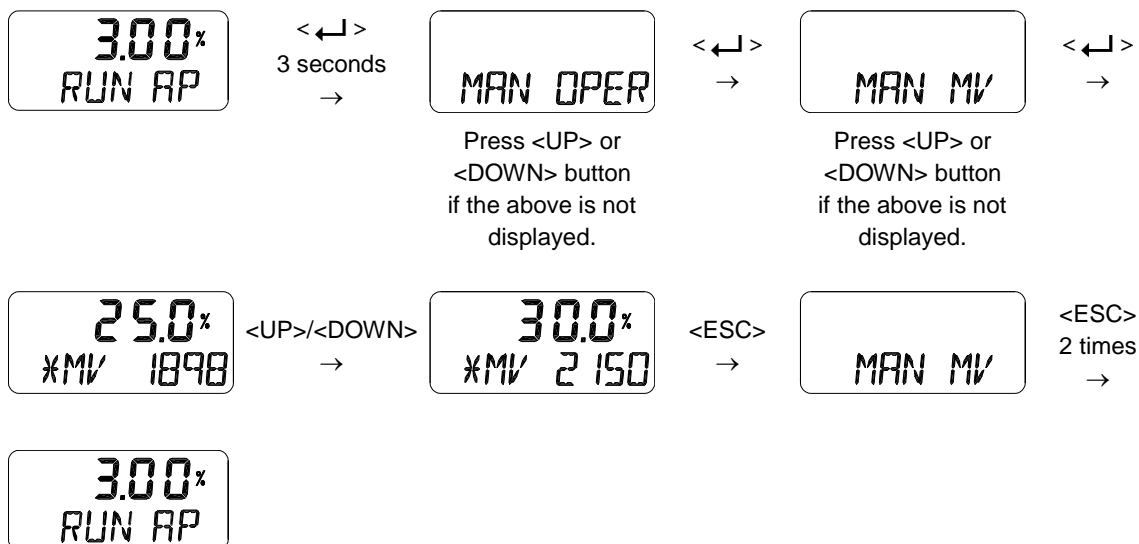

8.8 Control Parameters (CTL PARM)

Followings are the values changeable at the Control Parameters Mode.

- 1) Dead Band (dEAdbANd)
- 2) Forward P parameter (KP UP) and reverse P parameter (KP dN)
- 3) Forward Integral time parameter (TI UP) and reverse Integral time parameter (TI dN)
- 4) Forward D parameter (Kd UP) and reverse D parameter (Kd dN)
- 5) Auto Dead band Mode (AUTO db)
- 6) Performance Mode (PER)

8.8.1 Dead Band (dEAdbANd)

Deadband indicates the size of the allowable deviation that is set near the target position. If the valve has large packing friction, this value can be adjusted and set accordingly to prevent the limit cycle caused by the friction. If the deadband is set to 0.5%, its range is $\pm 0.5\%$ of the target.

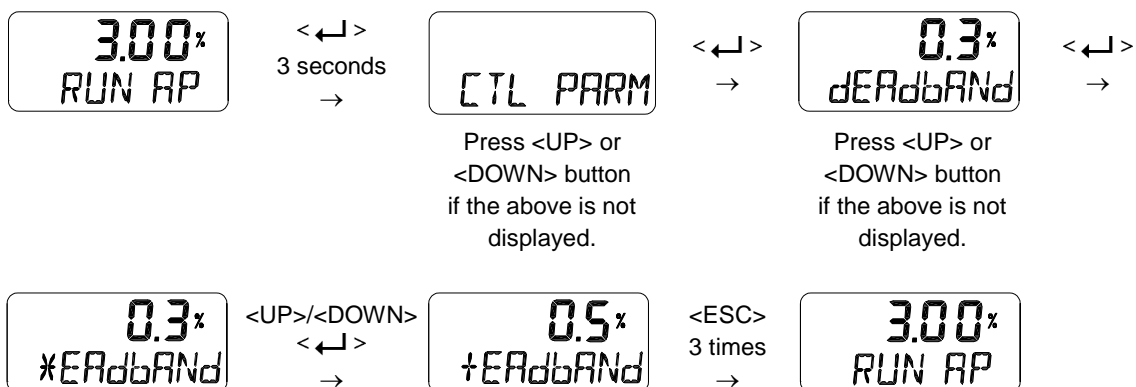

8.8.2 Forward P parameter (KP UP) and reverse P parameter (KP dN)

The KP parameter is the proportional control constant to the calibration signal to reduce the error between the target position and the current position, the KP UP is applied when the valve moves in the direction of increasing output air pressure, and KP dN is applied when the valve moves in the direction of venting output air pressure. A larger value of gains "KP UP" or "KP dN" moves the valve faster to reach a target position, but will tend to oscillate it if set to high. However, smaller gains improve stability, but make it slower to reach a target position.

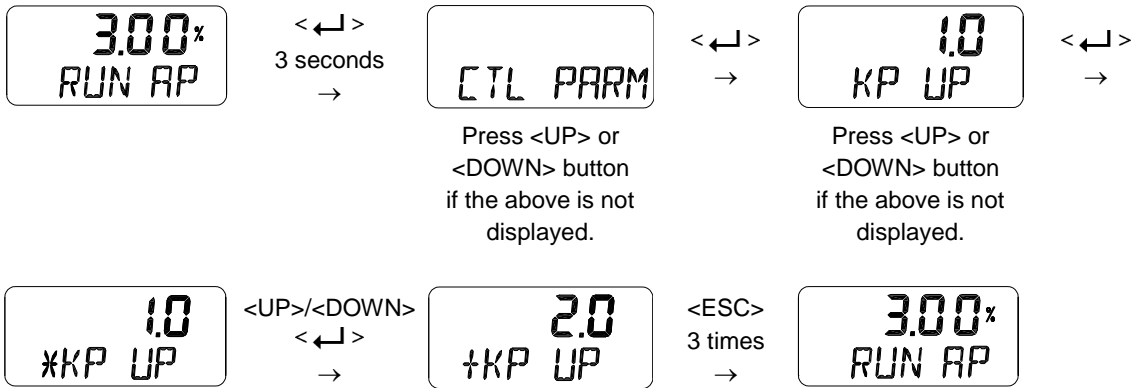

8.8.3 Forward Integral time parameter (TI UP) and reverse Integral time parameter (TI dN)

TI parameters are an integral value that add the error correction signal to the existing calibration signal, TI UP is applied when the valve moves in the direction of increasing the output air pressure, and TI DN is applied when the valve moves in the direction of decreasing the output air pressure. A smaller TI makes the valve faster to reach a target position and tends to cause oscillation.

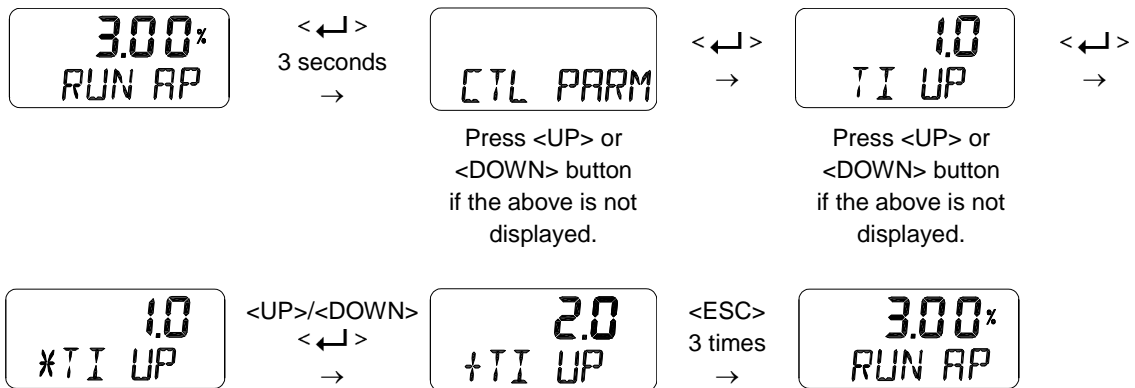

8.8.4 Forward D parameter (Kd UP) and reverse D parameter (Kd dN)

The Kd parameter is a differential value that adds the correction signal due to the rate of error to the existing calibration signal. Kd UP is applied when the valve moves in the direction of increasing output air pressure, and Kd dN is applied when the valve moves in the direction of decreasing output air pressure. A larger D value makes the valve hunting easier, and a smaller value can lead to poor linearity or dynamic properties.

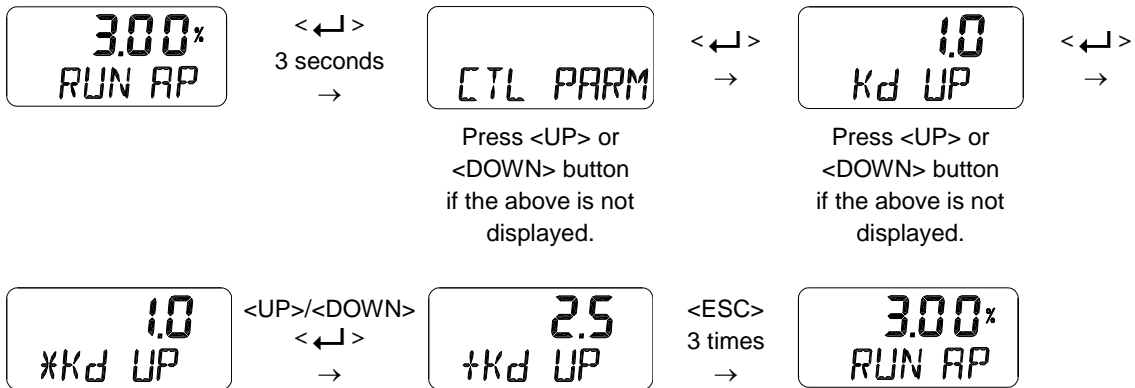

8.8.5 Auto Dead band Mode (AUTO db)

This function is used to suppress a hunting for valves with high static friction. The initial value is OFF and it shall be set to 0 % to activate the auto dead band automatically. The value is changed to a proper value once this mode is activated.

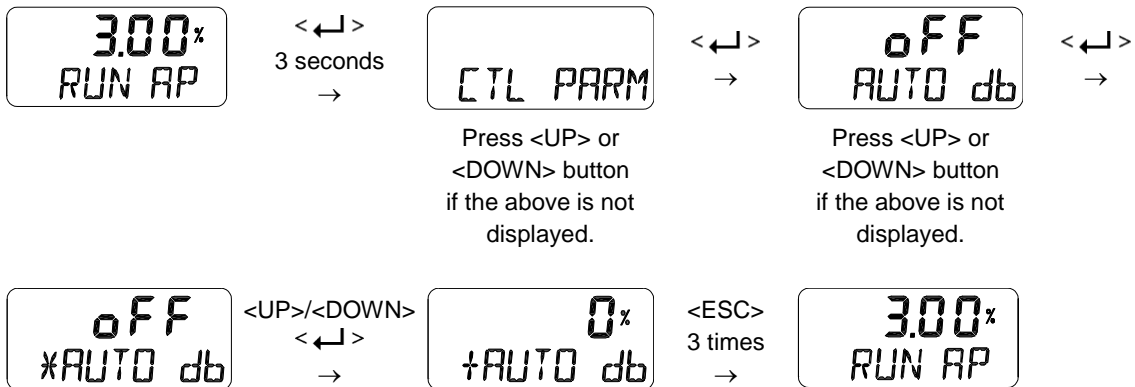

8.8.6 Performance Mode (PER)

This mode has three modes of operation: Stable, Normal, and Fast that allow you to select the required responsiveness. The performance modes in the order of Stable, Normal and Fast indicates the response characteristics from slow response to quick response.

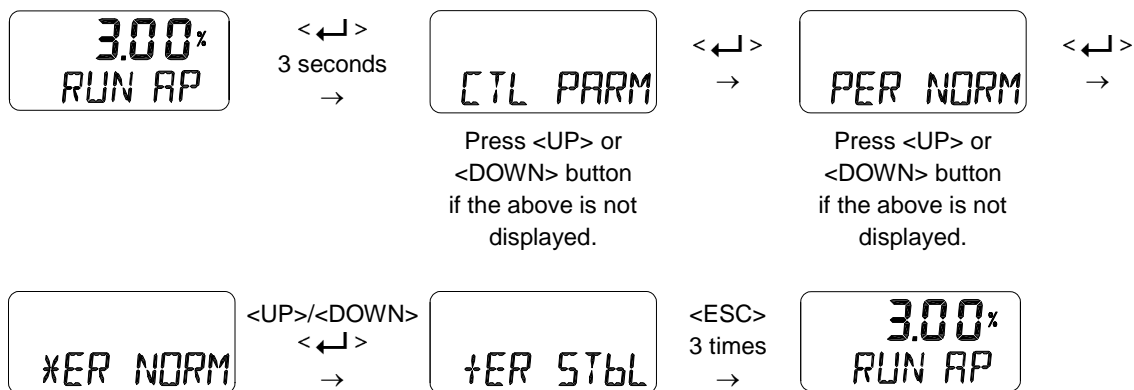

8.9 Input Configuration (IN CFG)

Followings are the values changeable at the Input Configuration Mode.

- 1) Signal Direction (SIG NORM / REVS)
- 2) Split Range Mode (SPLIT)
- 3) Custom Split Range Zero (CST ZERO)
- 4) Custom Split Range End (CST END)
- 5) Characterization Curves (CHAR)
- 6) User Set Characterization 5 Points (U5)
- 7) User Set Characterization 21 Points (U21)
- 8) Tight Shut Open (TSHUT OP)
- 9) Tight Shut Close (TSHUT CL)
- 10) Target Position Ramp Up Rate (RAMP UP) and Target Position Ramp Down Rate (RAMP dN)
- 11) Digital Input Function (dIF)
- 12) Digital Input Logic (dI LOGIC)

8.9.1 Signal Direction (SIG NORM / REVS)

This function changes the action type of the valve, NORM or REV. If NORM is selected, the air is completely released through output port 1 of the positioner when 4mA is applied, and the maximum air pressure is loaded to the actuator through output port 1 when 20 mA is applied. If set to REV, the maximum air pressure is loaded to the actuator via output port 1 when an input current of 4 mA is applied to the positioner.

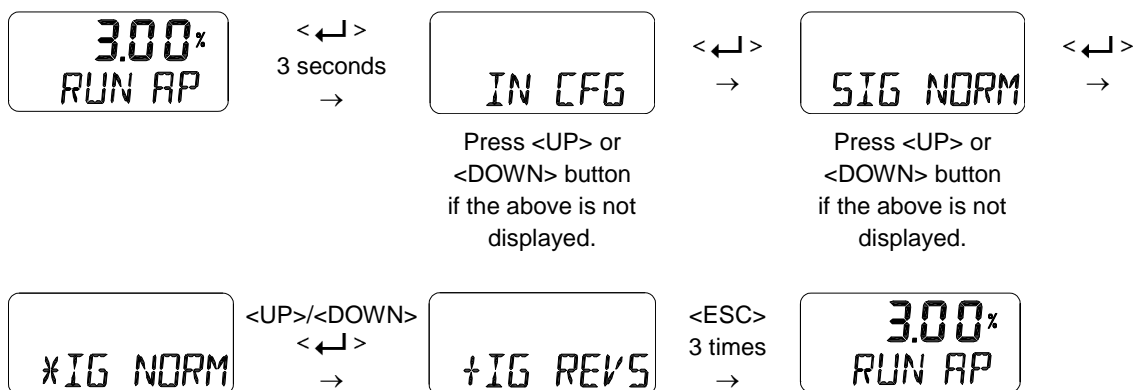

8.9.2 Split Range Mode (SPLIT)

This is used to set the range of the input signal to control the entire stroke of the valve. You can select one of the four input signals that consists of 4-20 mA, 4-12 mA, 12-20 mA, and user settings (Custom, CSt). 4-20 mA is the factory setting.

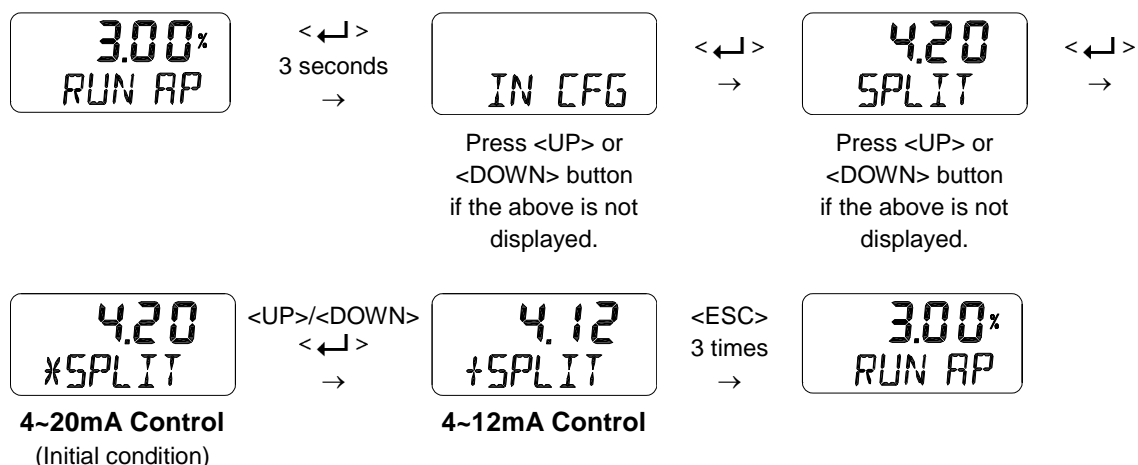

8.9.3 Custom Split Range Zero (CST ZERO)

It is used to set the current corresponding to the zeropoint when the valve position of 0 to 100% is controlled by the user-set CUSTOM. For example, if the valve is controlled by 6-20 mA instead of 4-20 mA, CST ZERO is 6 mA. However, the difference of the current between the origin point and the endpoint must be greater than 4 mA.

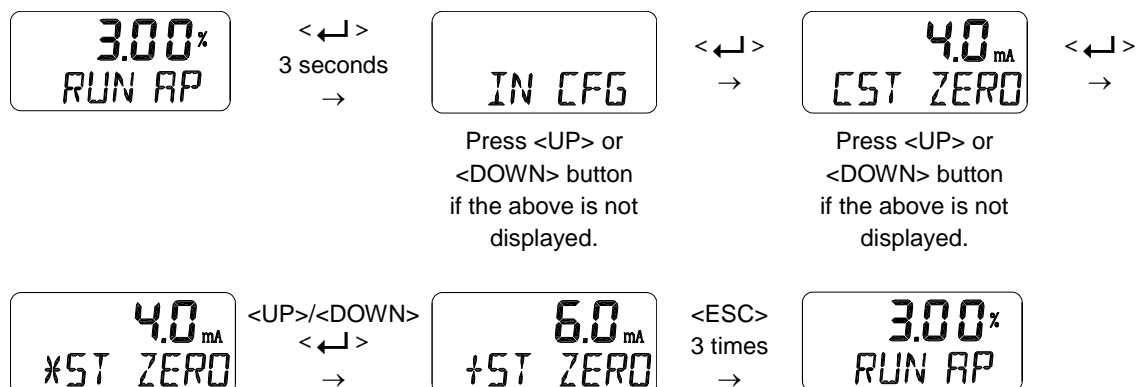

This function is activated by saving the Split Range Mode (SPLIT) of above Section 8.9.2 as “CSt”.

8.9.4 Custom Split Range End (CST END)

It is used to set the current corresponding to the endpoint when the valve position of 0 to 100% is controlled by the user-set CUSTOM. For example, if the valve is controlled by 4-18 mA instead of 4-20 mA, CST END is 18 mA. However, the difference of the current between the origin point and the endpoint must be greater than 4 mA.

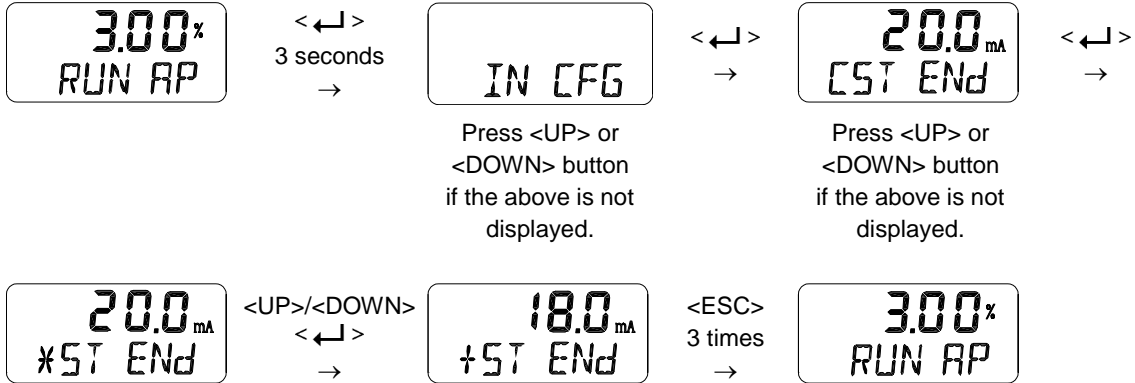

This function is activated by saving the Split Range Mode (SPLIT) of above Section 8.9.2 as "CSt".

8.9.5 Valve Flow Characterization Curves (CHAR)

The flow characteristic curve of valve is available by selecting one of the following: Linear(LIN), Quick Open(QO), Equal Percentage(EQ), User Set Characterization 5 Points (U5), User Set Characterization 21 Points(U21).

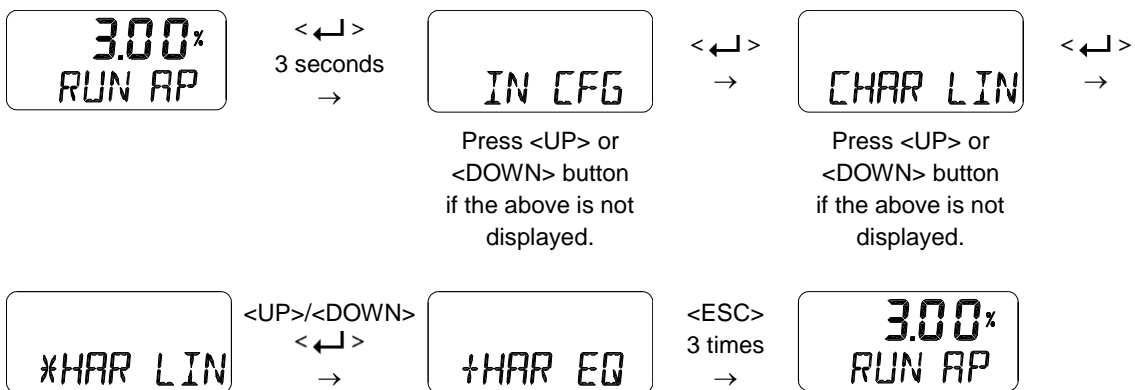
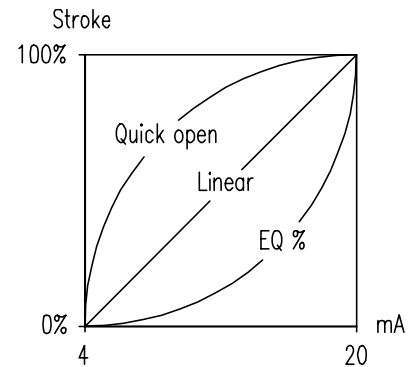

8.9.6 User Set Characterization 5 Points (U5)

A total of 5 target positions are set every 4 mA intervals. When shipped from the factory, the initial positions are P0 (4mA, 0%), P1 (8mA, 25%), P2 (12mA, 50%), P3 (16mA, 75%), and P4 (20mA, 100%). User can change all 5 points or only change partially and exit the menu by pressing <ESC> button.

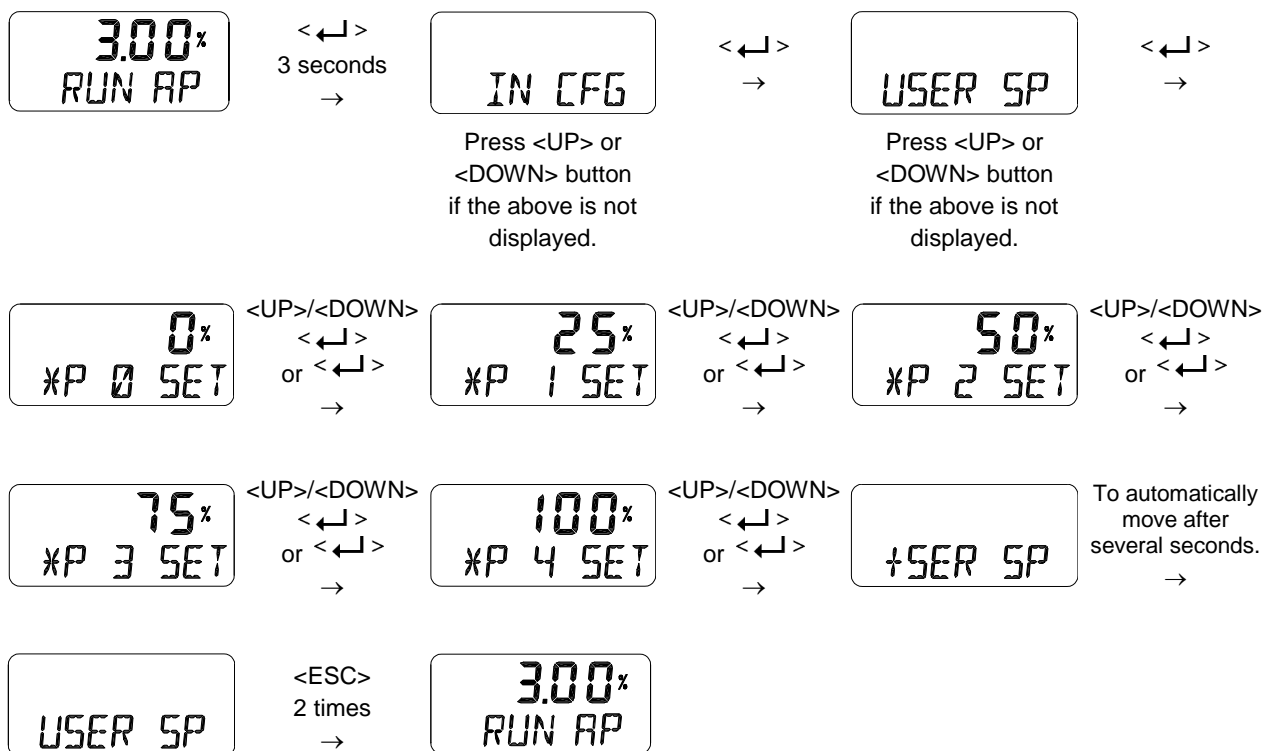

This function is activated by saving the Valve Flow Characterization Curves (CHAR) of above Section 8.9.5 as "U5".

8.9.7 User Set Characterization 21 Points (U21)

A total of 21 target points can be set every 0.8 mA intervals. When shipped from the factory, the initial P0 (4mA, 0%), P1 (4.8 mA, 5%), P2 (5.6 mA 10%), - - -, P19 (19.2 mA, 95%), and P20 (20 mA, 100%). For example, a characteristic curve below can be made through the settings of P1 to P20. User can change all 21 points or only change partially and exit the menu by pressing <ESC> button.

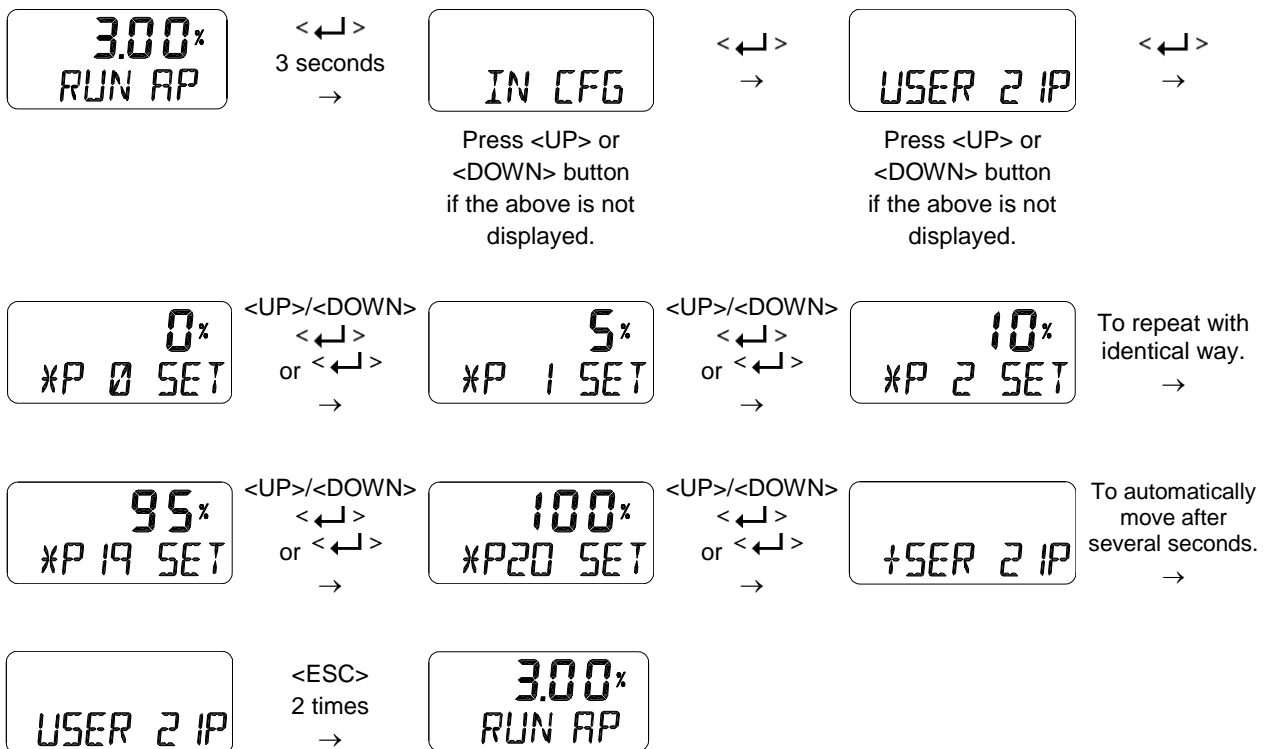
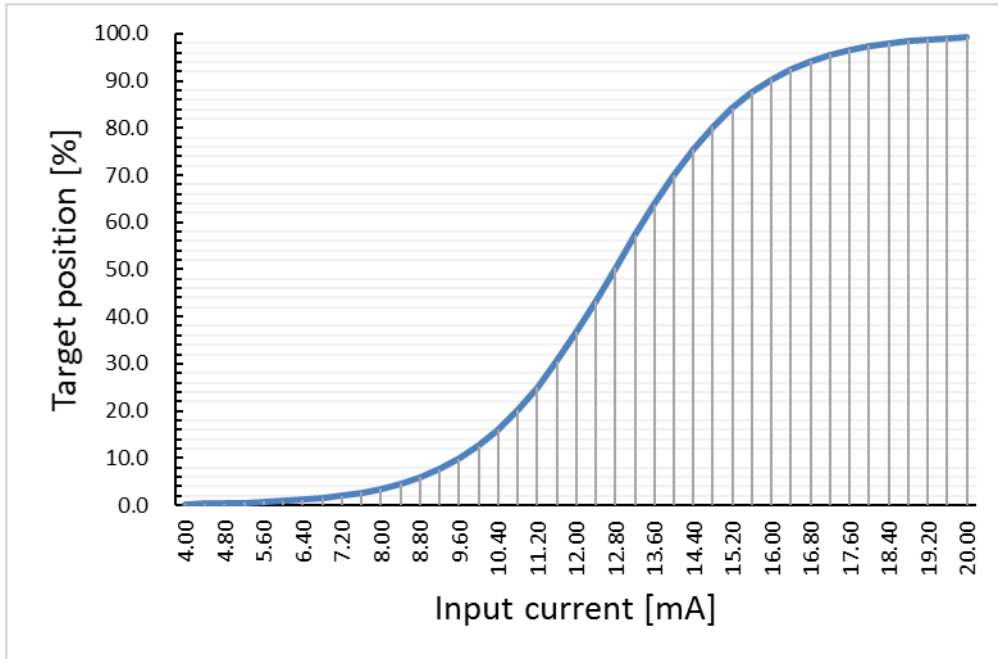

This function is activated by saving the Valve Flow Characterization Curves (CHAR) of above Section 8.9.5 as "U21".

8.9.8 Tight Shut Open (TSHUT OP)

It is used to ensure that the valve is fully opened with a large force. When the input signal SP is greater than the value set in the TSHUT OP, all available force is applied to OUT 1 port to tightly open the valve. If the input current of 4 mA is 0% of valve position and 20 mA is 100% of valve position, and the Tight Shut Open value is set to any position less than 100% (e.g. 95%), then the valve stroke will be 100% immediately when the input signal is over the set value (e.g. 95%). A full supply pressure applied to the actuator via the OUT1 port prevents leakage of the valve by shutting the valve tightly. However, when the value is set to 100%, Tight Shut Open function doesn't work.

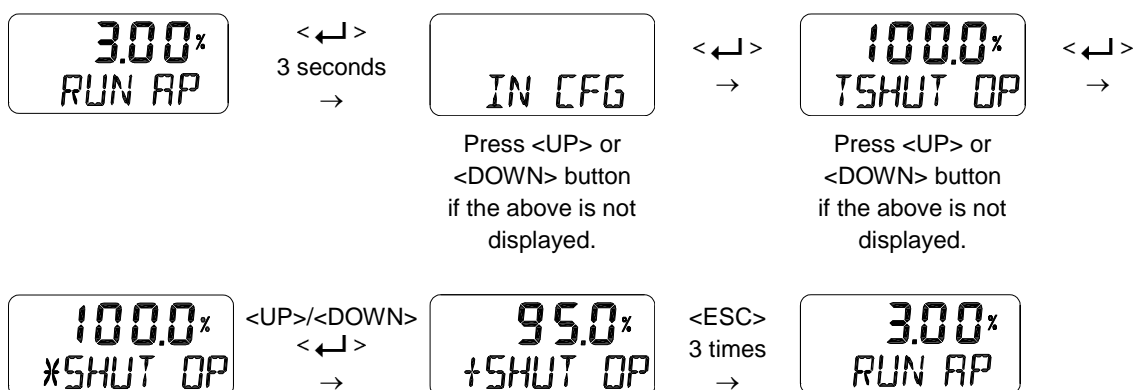

8.9.9 Tight Shut Close (TSHUT CL)

It is used to ensure that the valve is fully closed with a large force. When the input signal SP is smaller than the value set in the TSHUT CL, air pressure is vented through OUT 1 port to tightly close the valve. If the input current of 4 mA is 0 % of valve position and 20 mA is 100 % of valve position, and the Tight Shut Close value is set to any position larger than 0 % (e.g. 5%), then the valve stroke will be 0 % immediately when the input signal goes below the set value (e.g. 5%). The air venting from the actuator via the OUT1 port prevents leakage of the valve by shutting the valve tightly. However, when the value is set to 0%, Tight Shut Close function doesn't work.

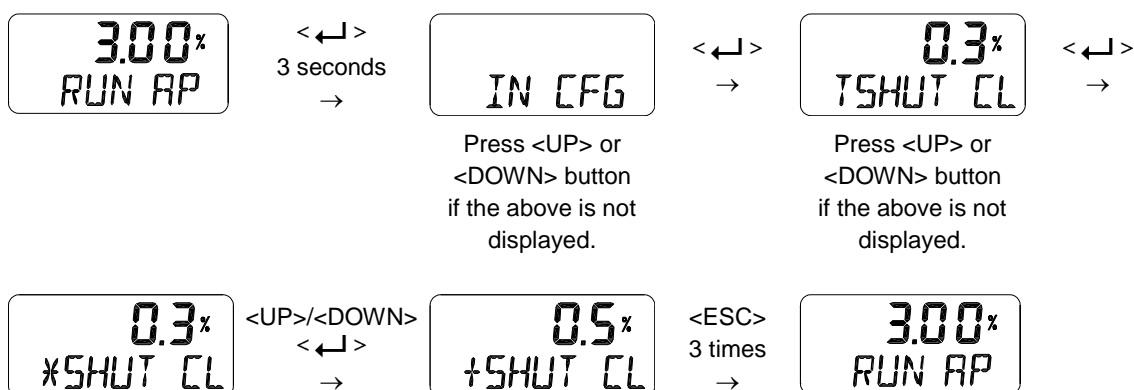

The following graph shows the operation of the valve stroke when the input signal corresponding to Tight Shut Open or Tight Shut Close is applied to the device.

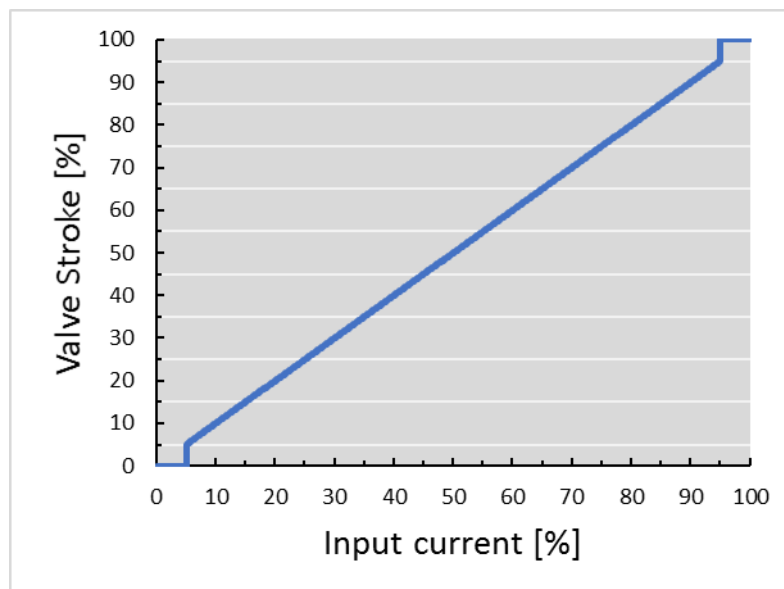

8.9.10 Target Position Ramp Up Rate (RAMP UP) and Target Position Ramp Down Rate (RAMP dN)

It is used to prevent the valve from moving too fast when the process to be controlled is too sensitive to rapid changes in flow or pressure. The unit of setting is %/sec. If you want to move 100% of the stroke for about 5 seconds, set it to 20 [%/sec]. The rising and falling speed can be set independently, and the valve will move to the target position as soon as possible when this function is switched off.

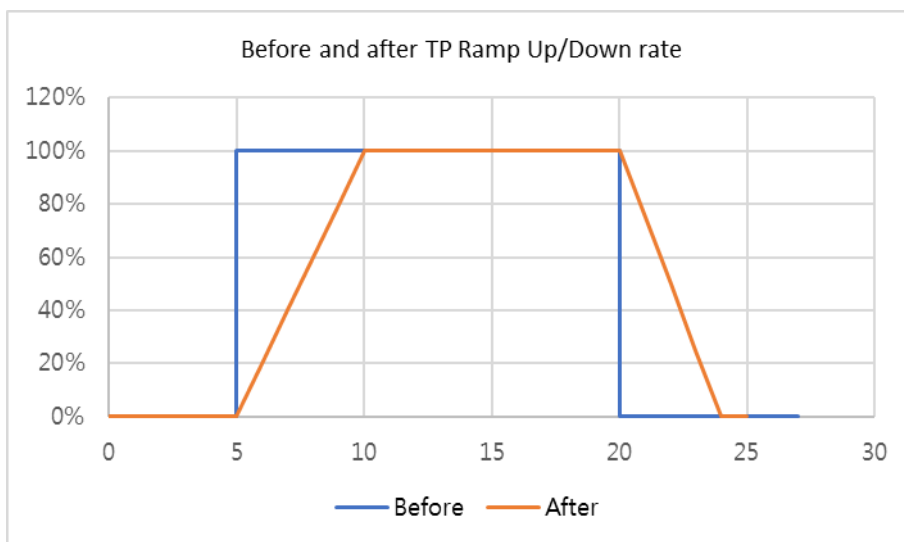

The curves below show the target position (red) and the actual position (blue) of the valve after applying SP Ramp Up/Down rate.

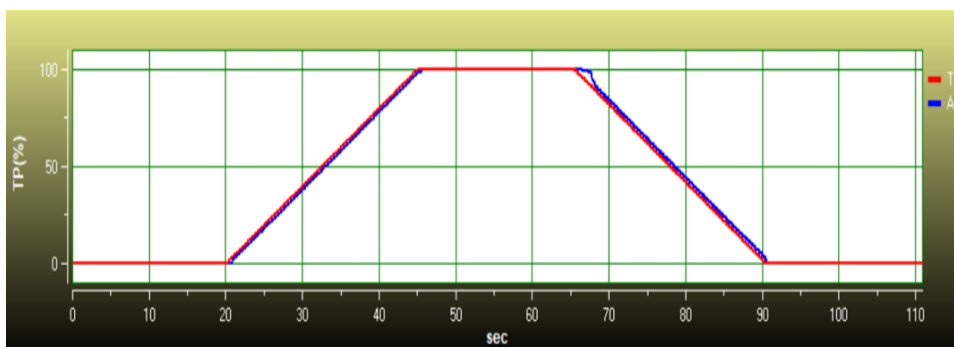

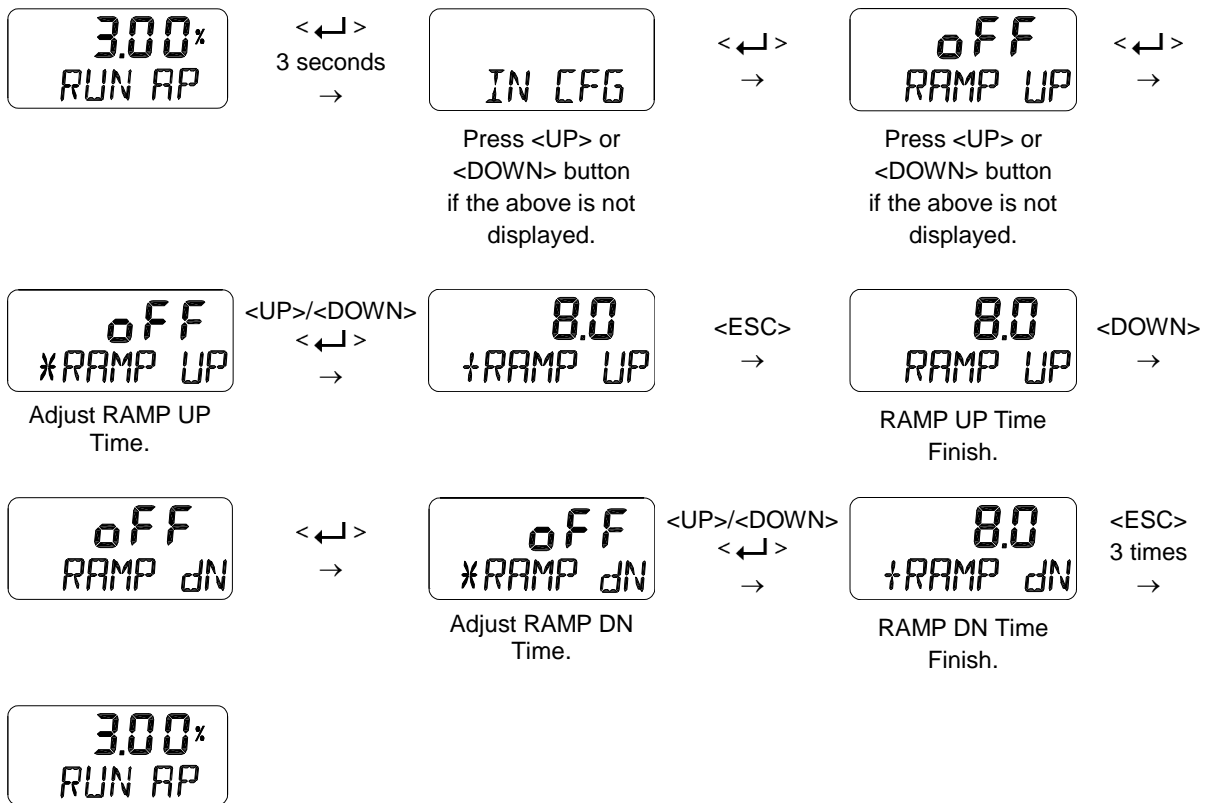

8.9.11 Digital Input Function (dIF)

It is used to perform a specific function as the signal is activated on the digital input port. The dIF should be configured taking into account Digital Input Logic of Section 8.9.12.

Function name	Abbreviation on LCD	Description
OFF	OFF	Not performing any function.
Fully Closed Position	FCL	Valve moves to a fully closed position, i.e. safe position.
Fully Open position	FOP	Valve moves to a fully open position.
Partial Stroke Test Start	PSTA	Start Partial Stroke Test
Partial stroke Test Stop	PSTO	Stop Partial Stroke Test in progress

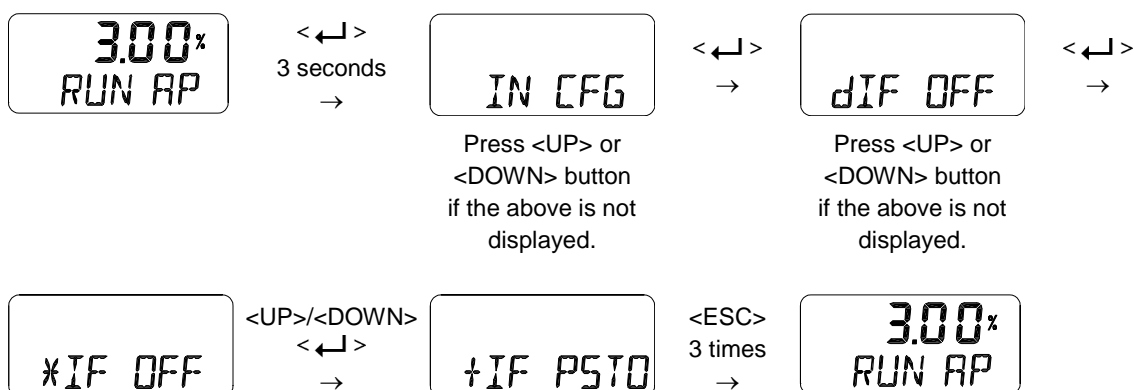

8.9.12 Digital Input Logic (dI LOGIC)

It sets the logic that activates digital input to High (HI) or Low (Lo). The initial factory setting is HI, which means that when 11 - 28 V DC voltage is applied, it is recognized as HI state. If Lo is set, when 0 - 5V is applied or the electric power is disconnected, it is recognized as Lo state.

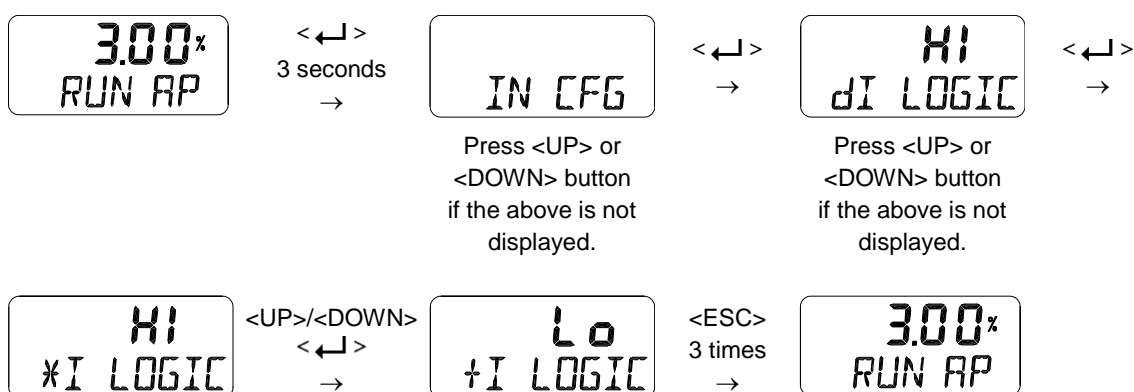

8.10 Output Configuration (OUT CFG)

Followings are the values changeable at the Output Configuration Mode.

- 1) Position Transmitter Direction (PTM NORM / REVS)
- 2) Position Transmitter Zero / End (PTM ZERO / ENd)
- 3) HART Feedback Direction (HT NORM / REVS)
- 4) Back Calculation (bACKCAL oFF / on)
- 5) Digital Output Function (dOF oFF / on)
- 6) Digital Output Logic (dO LOGIC)
- 7) Analog Output Function (AOF oFF / on)
- 8) Analog Output Logic (AO LOGIC)

8.10.1 Position Transmitter Direction (PTM NORM / REVS)

The analog feedback signal from the positioner can be changed to normal (NORM) or reverse (REVS), which means they are the same or reversed direction as the actual position.

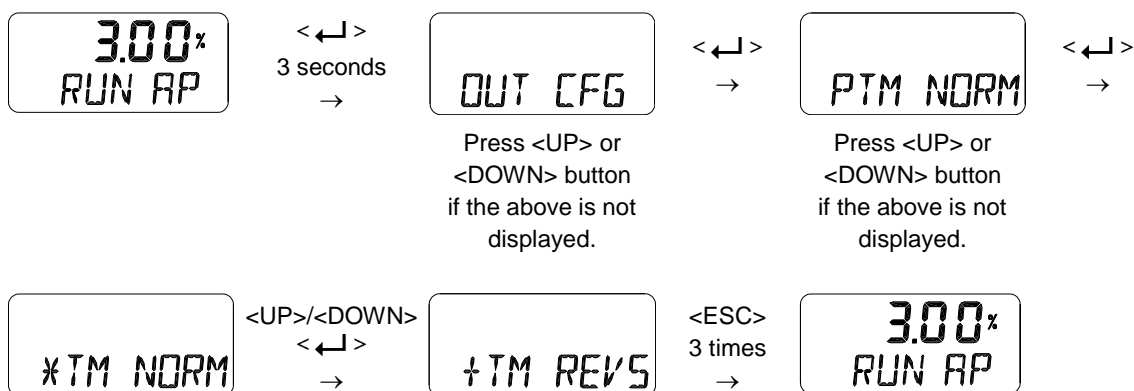

8.10.2 Position Transmitter Zero / End (PTM ZERO / ENd)

ZERO adjusts the zero point of the position transmitter (4mA feedback), and ENd adjusts the end point of the transmitter (20mA feedback). This is used when the analog output signal needs to be feedbacked differently than the actual position of the valve, or to be adjusted a little. A measuring instrument such as an ampere meter is needed to view the analog output signal, and it should be connected as shown below.

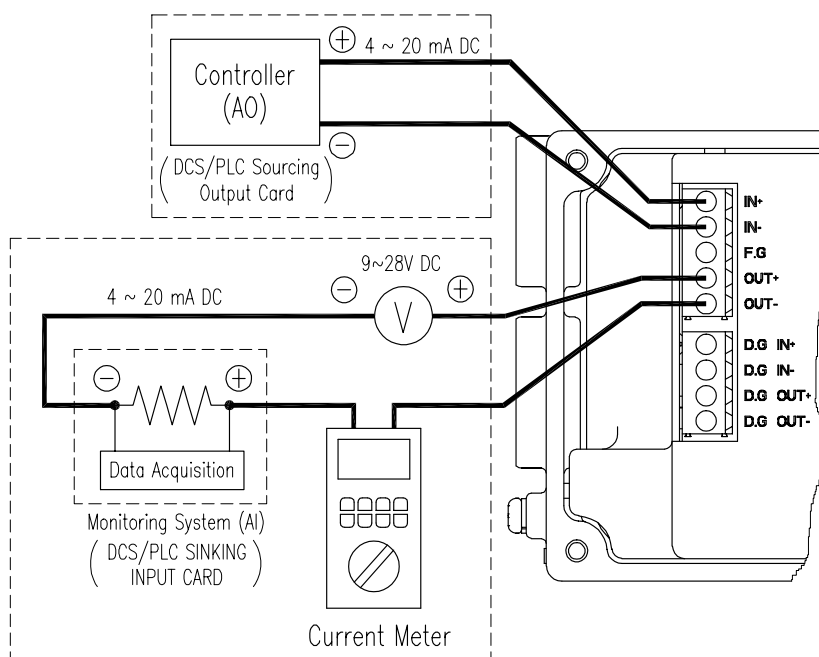
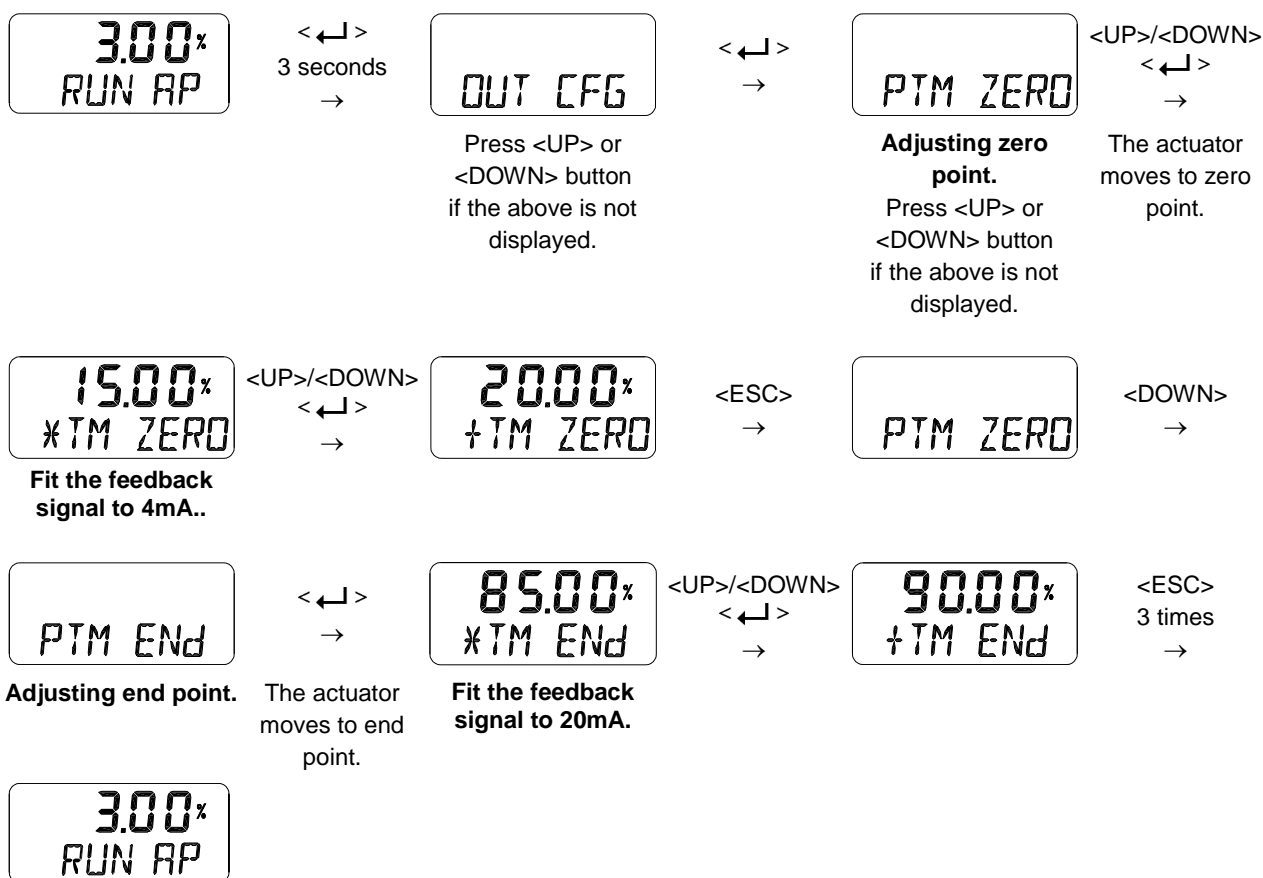
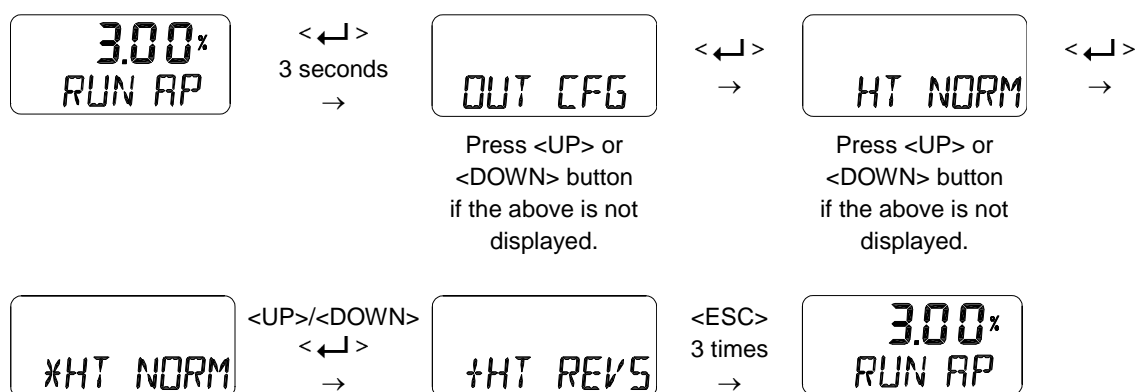

Fig. 8-3: Setting transmitter



8.10.3 HART Feedback Direction (HT NORM / REVS)

The feedback signal from the HART communication output of the positioner can be output in the same direction or the reversed direction as the actual position of the valve. NORM or REV is selected.



8.10.4 Back Calculation (bACKCAL oFF / on)

This function recalculates the output "RUN AP" value changed by the flow characteristics setting mode to display it linearly proportional to actual input current. For example, if the flow characteristic mode is set from "LIN" to "EQ", when an input current value of 8 mA (25 %) is applied, the target position is changed to 6.25 % and "RUN AP" is displayed as 6.25 % after the move. If you change the bACKCAL from OFF to ON, the "RUN AP" is displayed as 25 %.

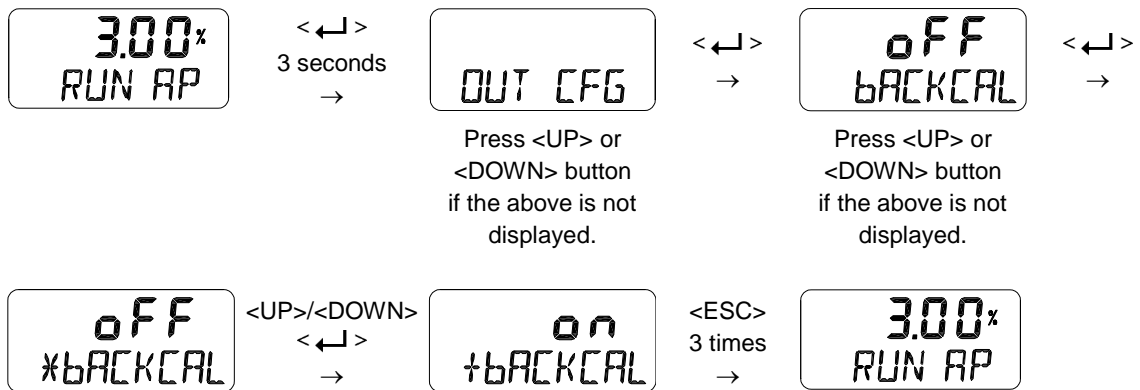

8.10.5 Digital Output Function (dOF)

This is used to output a specific alarm through the digital output port when triggered. Any of the alarms below can be configured to activate digital output. Assign any alarm to one of four NE107 signals to activate a digital output even when several alarms are triggered. The initial factory setting is OFF.

Alarm name to be assigned to digital out port	Abbreviation on LCD	Activated by digital output signal
OFF	OFF	Not activated when alarm occurs.
Temperature High Limit	TMPH	When the internal temperature exceeds the preset Temperature High Limit.
Temperature Low Limit	TMPL	When the internal temperature is lower than the preset Temperature Low Limit.
Travel High Limit	TVLH	When the valve position exceeds the Travel High Limit towards the 100 % position.
Travel Low Limit	TVLL	When the valve position is lower than Travel Low Limit towards the 0 % position.
Deviation Timeout	DVTO	When actual deviation greater than the preset Deviation persists longer than the preset Deviation Time.
PST Fail	PSTF	When Partial Stroke Test failed.
Loop Current Low	LPCL	When Loop input current is below 3.8 mA
Failure	FAIL	When the events classified as Failure in NE107 signals occur.
Functional Check	FUNC	When the events classified as Functional Check in NE107 signals occur.
Out of Specification	OUTS	When the events classified as Out of Specification in NE107 signals occur.
Maintenance required	MNTR	When the events classified as Maintenance Required in NE107 signals occur.

The assignment of any alarms to NE107 signals is shown in section 8.12.1 Default Alarms Settings. A review of the alarms that occurred the most recently can be done through 8.12.7 View Event Log (EVT LOG).

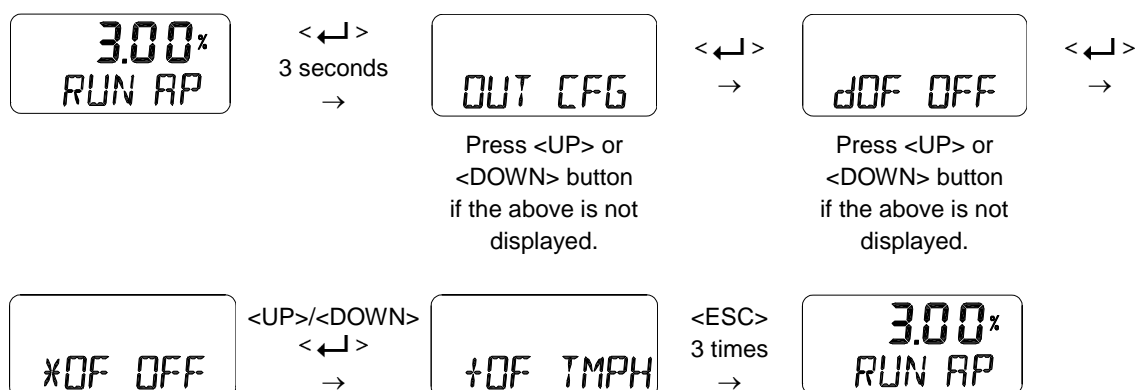

8.10.6 Digital Output Logic (dO LOGIC HI / Lo)

This logic function activates digital output to High (HI) or Low (Lo). The initial factory setting is HI, which means that when 5 - 28 V DC voltage is applied, the output current will be in the range of 2.2 to 14 mA flowing through the output port. Under the setting of Low (Lo), the output current will be less than 1.0 mA when 5 - 28 V DC is applied. A resistor is built into the electronic board limiting the output current.

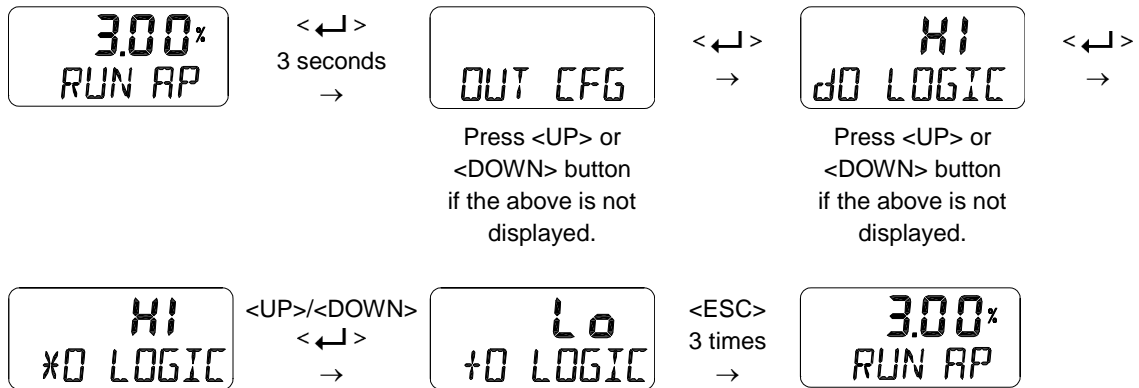

8.10.7 Analog Output Function (AOF)

This is used to output a specific alarm through the analog output port when triggered. If one of the alarms below occurs, it can be configured so that the analog output is activated. Assign any alarm to one of the four NE107 signals to activate an analog output signal required for any of the listed alarms. The initial factory setting is OFF. Analog output current is selected as 3.6 mA or 21.0 mA by Analog Output Logic (AO LOGIC).

Alarm name to be assigned to digital out port	Abbreviation LCD	Activated by analog out signal
OFF	OFF	Not activated when alarm occurs.
Temperature High Limit	TMPH	When the internal temperature exceeds the preset Temperature High Limit.
Temperature Low Limit	TMPL	When the internal temperature is lower than the preset Temperature Low Limit.
Travel High Limit	TVLH	When the valve position exceeds the Travel High Limit towards the 100 % position.
Travel Low Limit	TVLL	When the valve position is lower than Travel Low Limit towards the 0 % position.
Deviation Timeout	DVTO	When actual deviation greater than the preset Deviation persists longer than the preset Deviation Time.
PST Fail	PSTF	When Partial Stroke Test failed.
Loop Current Low	LPCL	When Loop input current is below 3.8 mA
Failure	FAIL	When the events classified as Failure in NE107 signals occur.
Functional Check	FUNC	When the events classified as Functional Check in NE107 signals occur.
Out of Specification	OUTS	When the events classified as Out of Specification in NE107 signals occur.
Maintenance required	MNTR	When the events classified as Maintenance Required in NE107 signals occur.

The assignment of any alarms to NE107 signals is shown in section 8.12.1 Default Alarms Settings. The verification of the alarms that occurred the most recently can be done through 8.12.7 View Event Log (EVT LOG).

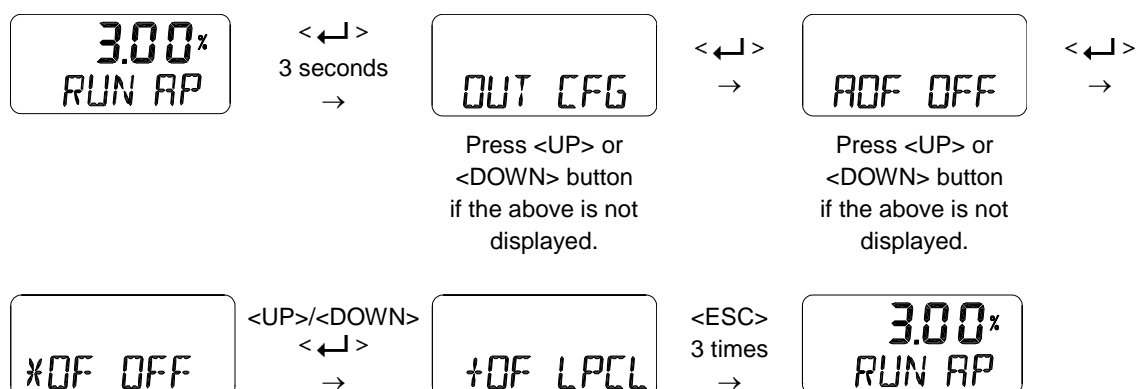

8.10.8 Analog Output Logic (AO LOGIC Lo / HI)

This logic function activates the analog output to High (HI) or Low (Lo). A current of less than 3.6 mA is sourced from the analog output port when the initial factory setting is low (Lo) with an external voltage source applied to the analog output. When the analog output logic is set to HI, more than 21.0 mA is sourced.

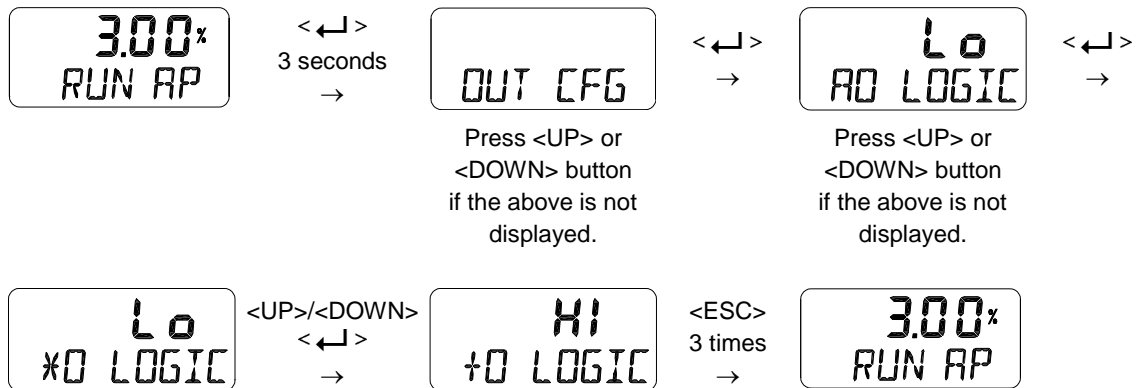

8.11 Device Configuration (dEV CFG)

Followings are the values changeable at the dEV CFG Mode.

- 1) Action Setting (ACT REVS / dIR)
- 2) Linear Interpolation (ITP oFF / on)
- 3) Lock of Parameters (Write Protect, W UNLOCK / LOCK)
- 4) Actual Position View Mode (View Mode, VI NORM / REVS)
- 5) Polling address setting (POL Addr 0 ~ 63)
- 6) Factory Reset (dEFAULT oFF / on)
- 7) Positioner Self-Test (SELFTEST)

8.11.1 Action Setting (ACT)

Reverse Action (REVS) or Direct Action (dIR) are automatically set by performing "AUTO 2" within the Auto Calibration function. However, this function is used when the user requires to change ACT REVS or ACT dIR to other action. Changing the action from Reverse Action (REVS) to Direct Action (dIR) or Direct Action (dIR) to Reverse Action (REVS) will also change the Signal Direction (SIG), Position Transmitter Direction (PTM), HART Feedback Direction (HT) and View Mode (VI).

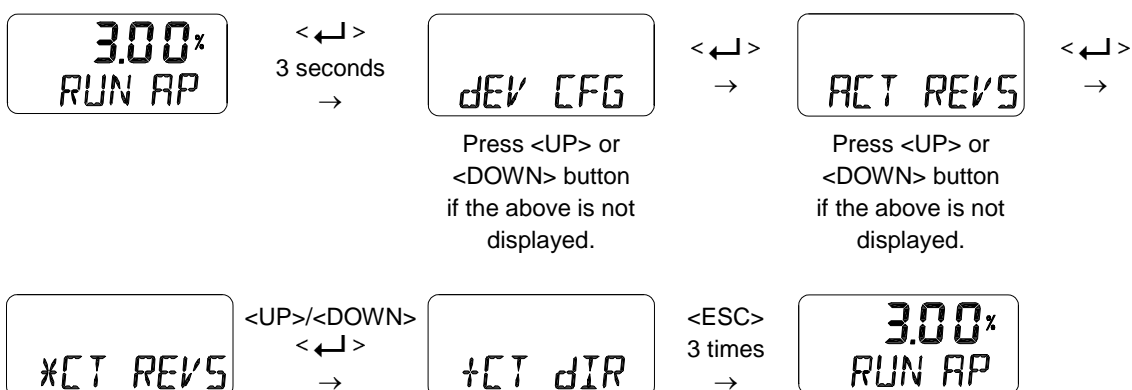

8.11.2 Linear Interpolation (ITP off / on)

ITP is used to compensate the linear motion of the actuator into rotary motion of the feedback lever. Following Auto Calibration, the ITP mode is set automatically to ON when the angle range of the feedback lever is greater than 20°, but it is set to OFF when this angle is less than 20° or rotary positioner is used.

The settings below are the process of manually changing the “ITP off” to the “ITP on”.

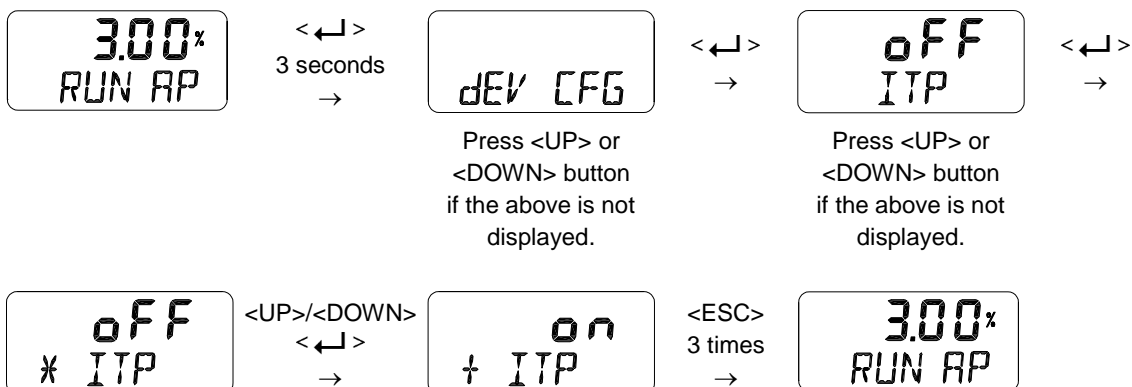

8.11.3 Lock of Parameters (Write Protect, W UNLOCK / LOCK)

This function is used to set (LOCK) or disable (UNLOCK) the lock for the parameters. Used to prevent the stored parameters from being changed.

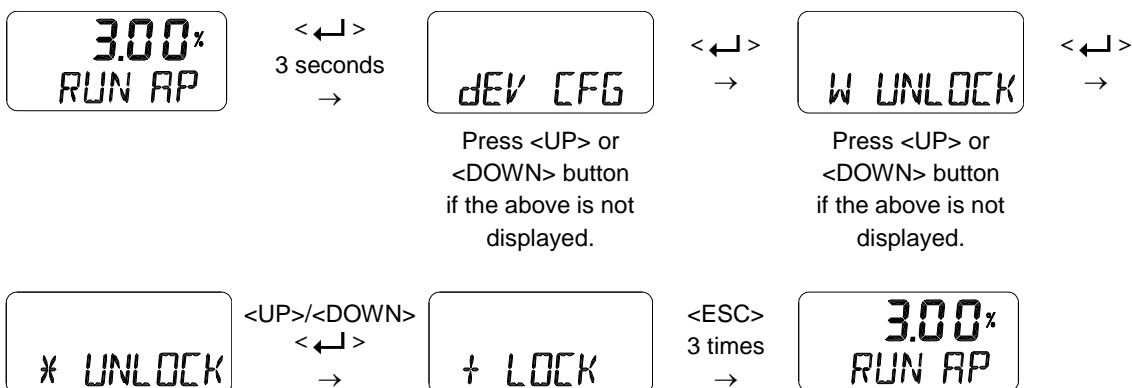

8.11.4 Actual Position View Mode (View Mode, VI NORM / REVS)

This function is used to set the "RUN AP" value on the LCD to be displayed as direct (NORM) or reversely (REVS) as the actual position of the valve.

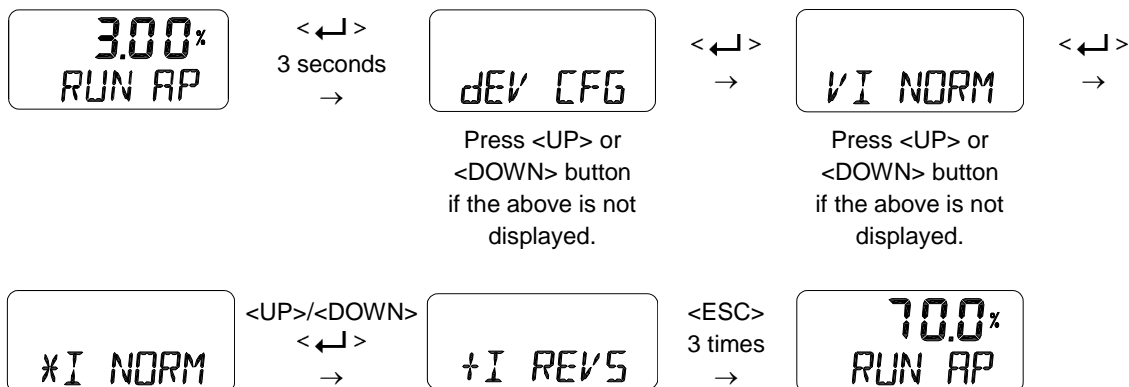

8.11.5 Polling address setting (POL Addr)

This function is used to set the address value of the positioner on HART(Highway Addressable Remote Transducer) communication. The value from 0 to 63 could be set and default is 0.

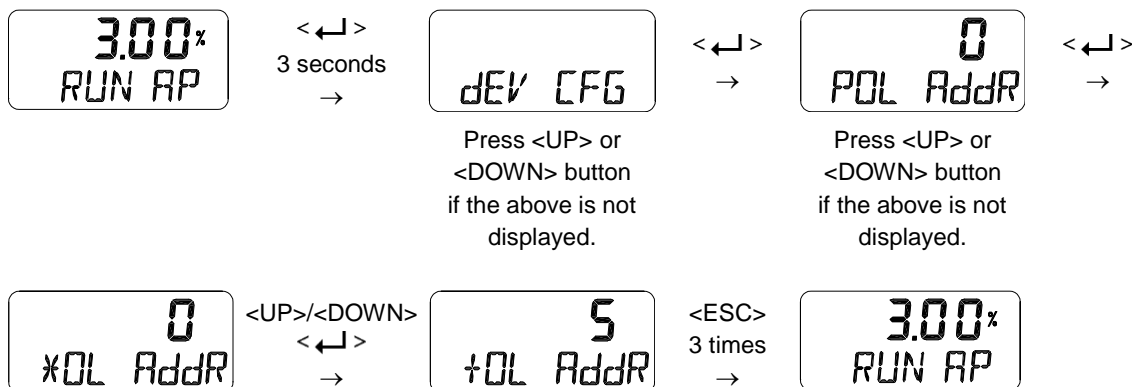

8.11.6 Factory Reset (dEFAULT oFF / on)

This function initializes all parameters stored in the positioner to initial factory setting. In the dEFAULT mode, pressing the Enter button for approximately 3 seconds enables ON/OFF setting mode and then setting it to ON resets all parameters.



Pay attention when using this mode as all the parameter values will be changed to the factory settings.

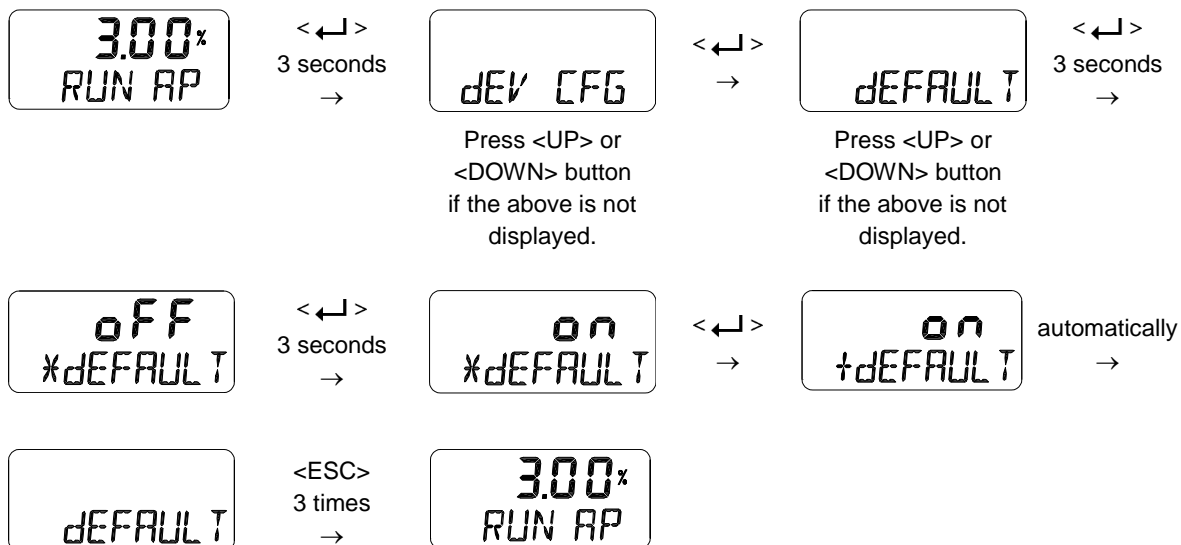

8.11.7 Positioner Self-Test (SELFTEST)

This function is used to diagnose the operation of the memory (RAM or NVM) inside the positioner. If no error is found during SELFTEST, the SELFTEST menu is displayed after FINISH is displayed, and if abnormalities are detected, the message "SEt / NVMW" is displayed.

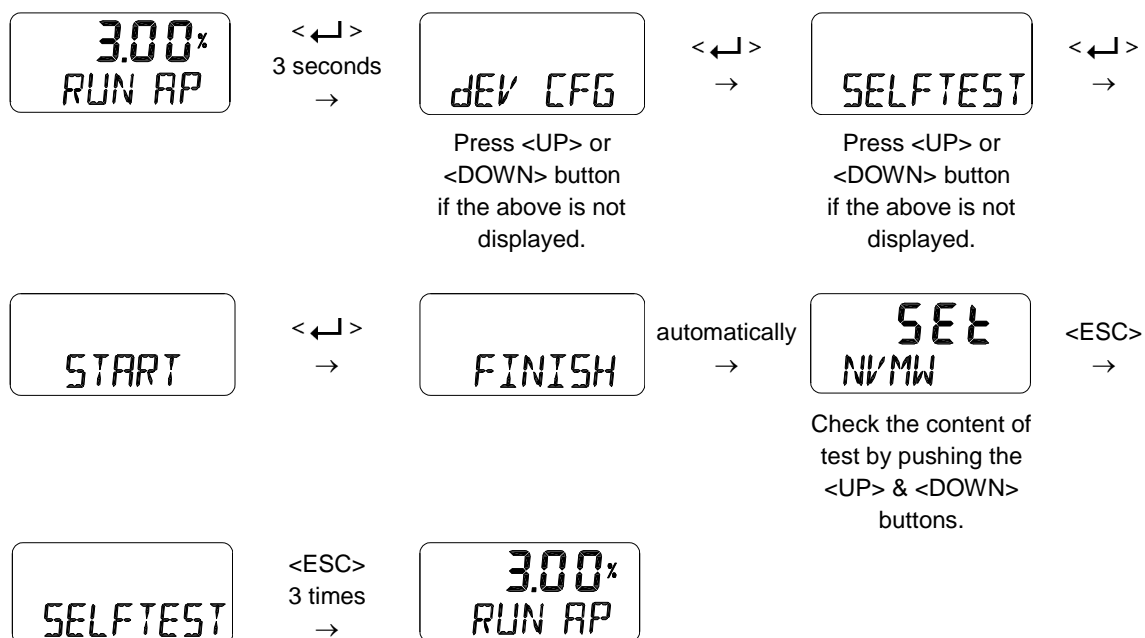

Diagnostic message

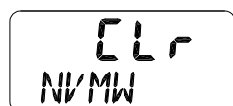

If the abbreviation displayed at the top line is "Set", it means the event has been created, and if it is "CLr", the message has been cleared. NVMW at the bottom is an alarm message that has occurred. See "8.14 Status and Alarm Code" for alarm details.

8.12 Diagnosis Mode (dIAGNd)

Followings are the values changeable at the dIAGNO Mode.

- 1) Default Alarm Settings
- 2) Process Status (PS)
- 3) Device Status (dS)
- 4) View Monitoring Counts (VI CNTS)
- 5) Diagnostic Limit Configuration (LIMT CFG)
- 6) Reset Alarm Status (RST ALRM)
- 7) View Event Log (EVT LOG)
- 8) Partial Stroke Test Record (View PST Result Record, PST RSLT)
- 9) PST Configuration (PST CFG)
- 10) Run PST (PST NOW)
- 11) Periodic PST Test (PST Schedule, PST SCHd)

8.12.1 Default Alarm Settings

The table below shows the initial values set at factory for handling the positioner status or associated process conditions. To trigger any alarm automatically when a specific event occurs, the corresponding alarm needs to be set to “Enable”. Each status or alarm is also set to either Failure, Out of Specification, Maintenance Required, or Functional Check depending on the classification of the NE107 signal, so that the corresponding NE107 symbol is displayed when a preset alarm occurs. This setting can be reassigned to the one of NE107 signals, depending on the operator's decision. As shown in the table below, the status / alarms that can be manually reset are Auto Calibration Running, Diagnosis Running, Critical NVM Fail, Non-Critical NVM Fail, PST Fail and Auto Calibration Fail. The activation of each status / alarm and the classification of NE107 signals can be set through HART communication, and the five alarms below can be even activated using the LCD screen and button.





- Travel High Limit, Travel Low Limit, Temperature High Limit, Temperature Low Limit, Deviation Timeout

Status / Alarm	Activation	NE107 signals	Is the Status or Alarm reset manually?
Local Operation Active	Enable	Functional Check	No
Auto Calibration Running	Enable	Functional Check	Yes
PST Running	Enable	Functional Check	No
Diagnosis Running	Enable	Functional Check	Yes
Position Sensor High Limit	Disable	Out of Specification	No
Position Sensor Low Limit	Disable	Out of Specification	No
Critical NVM Fail	Enable	Failure	Yes
Non Critical NVM Fail	Disable	Failure	Yes

Status / Alarm	Activation	NE107 signals	Is the Status or Alarm reset manually?
Cycle Count Limit	Disable	Maintenance Required	No
Travel Accumulate Limit	Disable	Maintenance Required	No
Operating Count Limit	Disable	Maintenance Required	No
Temperature High Limit	Disable	Out of Specification	No
Temperature Low Limit	Disable	Out of Specification	No
Travel High Limit	Disable	Out of Specification	No
Travel Low Limit	Disable	Out of Specification	No
Deviation Timeout	Enable	Out of Specification	No
PST Fail	Enable	Failure	Yes
Temperature Sensor Fail	Disable	Failure	No
Position Sensor Fail	Enable	Failure	No
Abnormal Drive Signal	Disable	Out of Specificaion	No
I Value High Limit	Disable	Out of Specification	No
I Value Low Limit	Disable	Out of Specification	No
Travel Cutoff High Limit	Disable	Out of Specification	No
Travel Cutoff Low Limit	Disable	Out of Specification	No
Not Calibrated	Disable	Maintenance Required	No
Auto Calibration Fail	Enable	Maintenance Required	Yes
Zero Point Drift	Disable	Maintenance Required	No
End Point Drift	Disable	Maintenance Required	No
Stack Overflow	Enable	Failure	No
Communication Error Limit	Disable	Out of Specification	No
Full Close Count Limit	Disable	Maintenance Required	No
Full Open Count Limit	Disable	Maintenance Required	No
Loop Current High Limit	Disable	Out of Specificaion	No
Loop current Low Limit	Enable	Failure	No
DI Status Change	Disable	Not defined	No
DO Status Change	Disable	Not defined	No
Diagnosis Fail	Disable	Failure	No

8.12.2 Process Status (PS)

The status of the current process is indicated as GOOD, NE107 symbol, and abbreviation for alarm.

NE107 symbols	Abbreviation	Function
None	PS GOOD	Good
	PS FAIL	Failure
	PS FUNC	Functional Check
	PS OUTS	Out of Specification
	PS MNTR	Maintenance Required



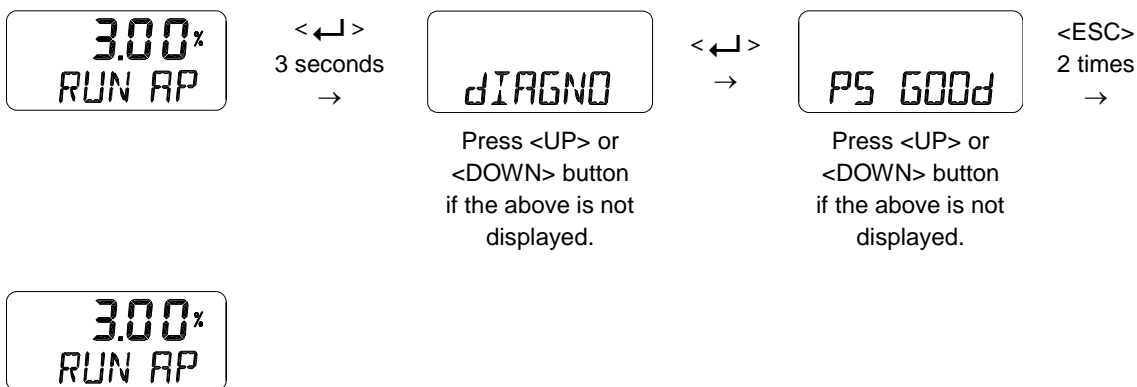

Alarms generated by each process are assigned to one of the four NE107 signals at initial factory settings and can be used by reassigning the already preset signals as required. Reassignment of NE107 signals to process alarms shall be made using HART communication. The table below shows the type of the process status or alarm and its abbreviations. See 8.14 Status and Alarm Code for the details of each alarm.

Process Alarm	Abbreviation
Cycle Count Limit	CYCC
Travel Accumulator Limit	TVLA
Operating Count Limit	OPRC
Temperature High Limit	TMPH
Temperature Low Limit	TMPL
Travel High Limit	TVLH
Travel Low Limit	TVLL
Deviation Timeout	dVTO
Travel Cutoff High Limit	TVCH
Travel Cutoff Low Limit	TVCL
Zero Point Drift	ZPDR
End Point Drift	EPDR
Full Close Count Limit	FCLC
Full Open Count Limit	FOPC
Loop Current High Limit	LPCH
Loop Current Low Limit	LPCL



8.12.3 Device Status (dS)

The status of the current device is indicated as GOOd, NE107 symbol, and abbreviation for alarm.

NE107 symbols	Abbreviation	Function
None	dS GOOd	Good
	dS FAIL	Failure
	dS FUNC	Functional Check
	dS OUTS	Out of Specification
	dS MNTR	Maintenance Required

Reassignment of NE107 signals to device alarms shall be made using HART communication. The table below shows the type of the device status or alarm and its abbreviations. See 8.14 Status and Alarm Code for the details of each alarm.

Device Alarm	Abbreviation
Loop Operation Active	LOPA
Auto Calibration Running	CALR
PST Running	PSTR
Diagnosis Running	dIGR
Position Sensor High Limit	PSNH
Position Sensor Low Limit	PSNL
Critical NVM Fail	NVMF
Non-Critical NVM Fail	NVMW
Abnormal Drive Signal	AbdS
Not Calibrated	NCAL
Auto Calibration Fail	CALF
Communication Error Limit	COMM
DI 0 Status	dI0S
DO 0 Status	dO0S
Diagnosis Fail	dIGF
PST Fail	PSTF

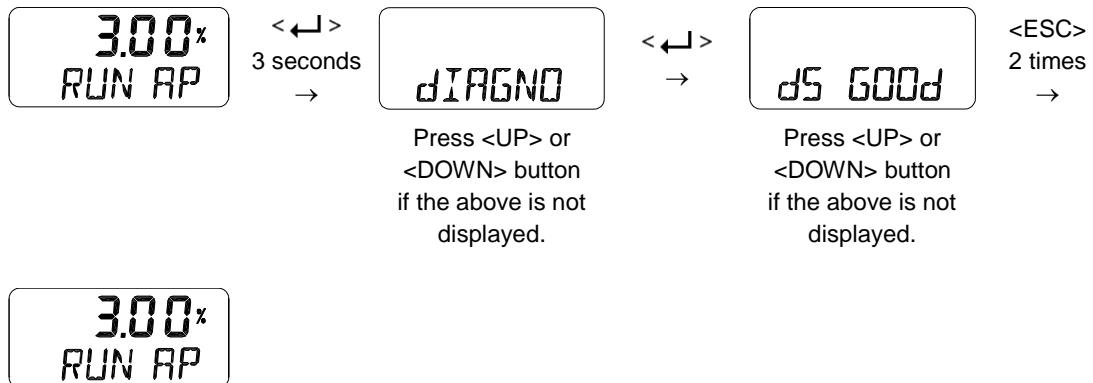

8.12.4 View Monitoring Counts (VI CNTS)

It is used to view the accumulated data information for valve movement up to now.

Counter Name	Abbreviation [unit]	Function
Cycle Count	CYCL CNT	The accumulated number of times the valve has changed its direction. It is accumulated only when the valve change direction while Cycle Count Deadband is exceeded.
Travel Accumulator	TVL ACUM [%]	The total valve travel accumulated whenever Travel Accumulator Deadband is exceeded.
Operating Count	OPER CNT	Total number of input change applied to I/P converter.
Fully Open Count	FOP CNT	The accumulated number of times the valve has been fully open.
Fully Closed Count	FCL CNT	The accumulated number of times the valve has been fully closed.

The upper limit for the five counters can be set so that an alarm is triggered if the accumulated counter value exceeds this limit. Other parameters related to the counters, such as Cycle Count Deadband, Travel Accumulator Deadband or Upper Limits for the counters can be only set through HART using DD or DTM.

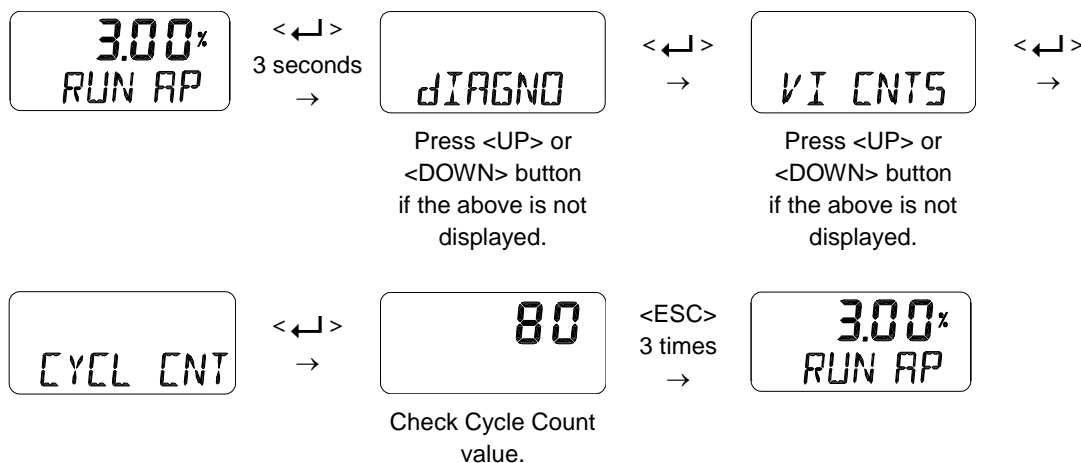

8.12.5 Diagnostic Limit Configuration (LIMT CFG)

This configuration is used to set the upper or lower limit that is generated by the Travel High Limit Alarm, Travel Low Limit Alarm, Temperature High Limit Alarm, Temperature Low Limit Alarm, and Deviation Timeout Alarm. Even if this condition is met, the corresponding alarm will not be triggered if the alarm(s) is not enabled.

Upper / Lower Limit or Enable	Abbreviation [unit]	Description
Travel High Limit	TVL HI [%]	Alarm is triggered if the valve exceeds TVL HI. The initial factory setting is 100 %.
Travel Low Limit	TVL LO [%]	Alarm is triggered if the valve moves to the position lower than TVL LO. The initial factory setting is 0 %.
Temperature High Limit	TEMP HI [°C]	Alarm is triggered if the internal temperature exceeds TEMP HI. The initial factory setting is +85°C
Temperature Low Limit	TEMP LO [°C]	Alarm is triggered if the internal temperature is lower than TEMP LO. The initial factory setting is -30°C
Deviation Time	dV TIME [sec]	Alarm is triggered if actual deviation greater than the preset "dV db" persists longer than the preset "dV TIME". The initial factory setting is 60sec and 5%.
Deviation Deadband	dV db [%]	
Travel High Limit Alarm Enable	AL TVLH	These are used to set "on" or "oFF" for each alarm. When set to oFF, the alarm does not occur even if the conditions are met. All the initial factory settings are oFF.
Travel Low Limit Alarm Enable	AL TVLL	
Temperature High Limit Alarm Enable	AL TMPH	
Temperature Low Limit Alarm Enable	AL TMPL	
Deviation Timeout Alarm Enable	AL dVTO	

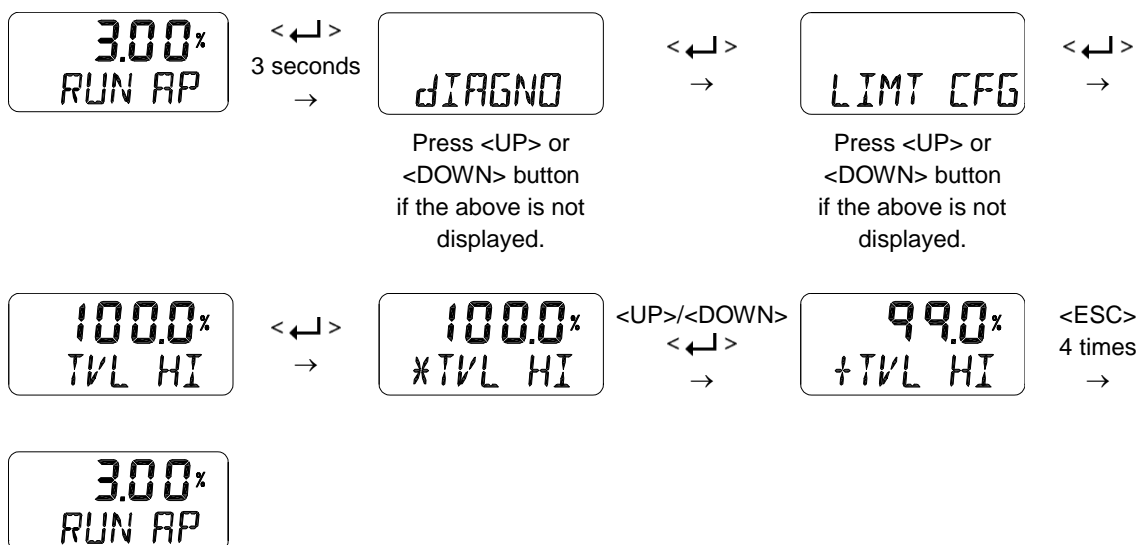

8.12.6 Reset Alarm Status (RST ALRM oFF / on)

The alarm is automatically released when the cause of the alarm is removed. For example, if a high-temperature alarm is created, the alarm is automatically released when internal temperature drops below the Temperature High Limit. However, if the Partial Stroke Test fails or Auto Calibration fails, use this function to release the alarm.

Below is an alarm list that can be released using the RST ALRM function.

- 1) Auto Calibration Running
- 2) Diagnosis Running
- 3) Critical NVM Fail
- 4) Non-Critical NVM Fail
- 5) PST Fail
- 6) Auto Calibration Fail

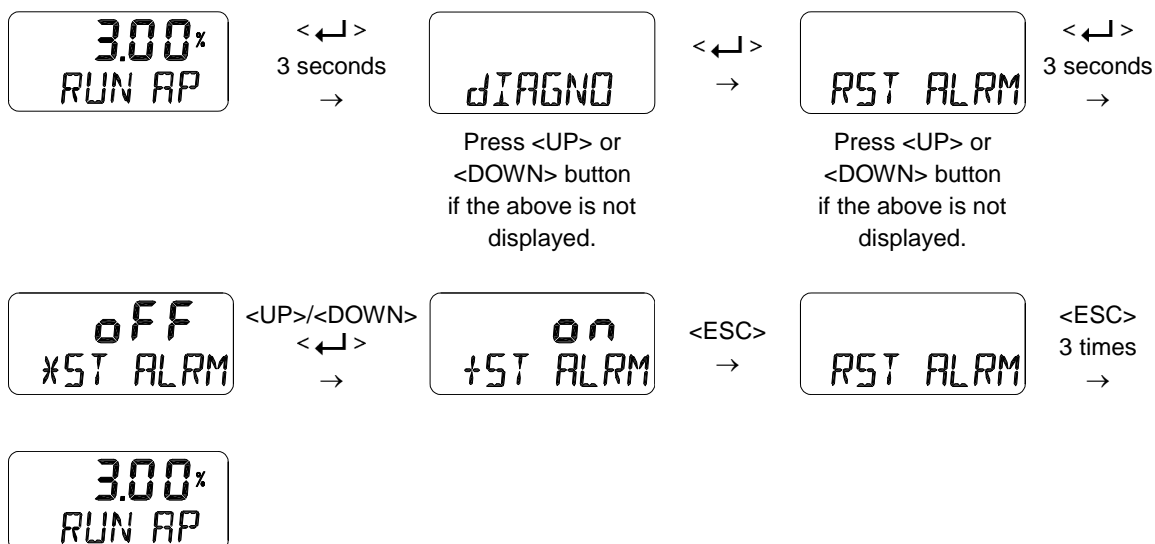

8.12.7 View Event Log (EVT LOG)

This is used to show the 20 most recent events that occurred in operation. Record 0 is the most recent of the 20 events and Record 19 is the oldest event. The event detail shows the time when the event occurred (EVT TIME) as well as the content of the event (EVT INFO). See 8.14 Status and Alarm Codes for an abbreviation and description of the event details.

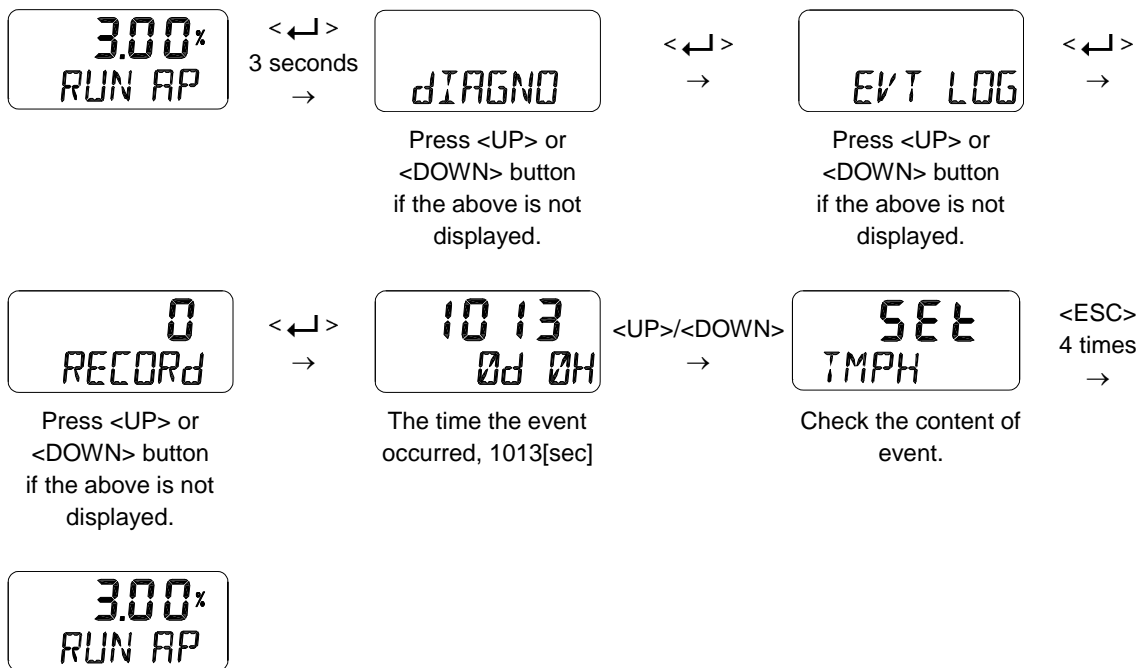

Event Message Description



The “SEt on the upper section of screen shows that a specific event has occurred, while the “CLr” means that the event has been removed. The “TMPH” displayed on the bottom section indicates an abbreviation for the alarm.

8.12.8 Partial Stroke Test Record (View PST Result Record, PST RSLT)

This is used to show information about the 10 most recent Partial Stroke Tests performed. Record 1 is the most recent of the 10 PST histories, and Record 10 is the result of the oldest PST operation. The response time (RT), response code (RC), and dead time (dT) after the PST operation are also shown. Response time represents the time to reach the target position from the PST start, and deadtime indicates the time from the start of the PST command to the moment the valve starts to move. The table below describes the response codes.

Response Code (RC)	Description
1	Pass
2	Out of Tolerance
3	Time Out
4	Abort, but reserved
5	Hunting
6	Abnormal Shutdown
256	Stopped by low current less than 4 mA at Analog Input Port. Venting air through output port 1.
512	Stopped by Digital Input Function (dIF)

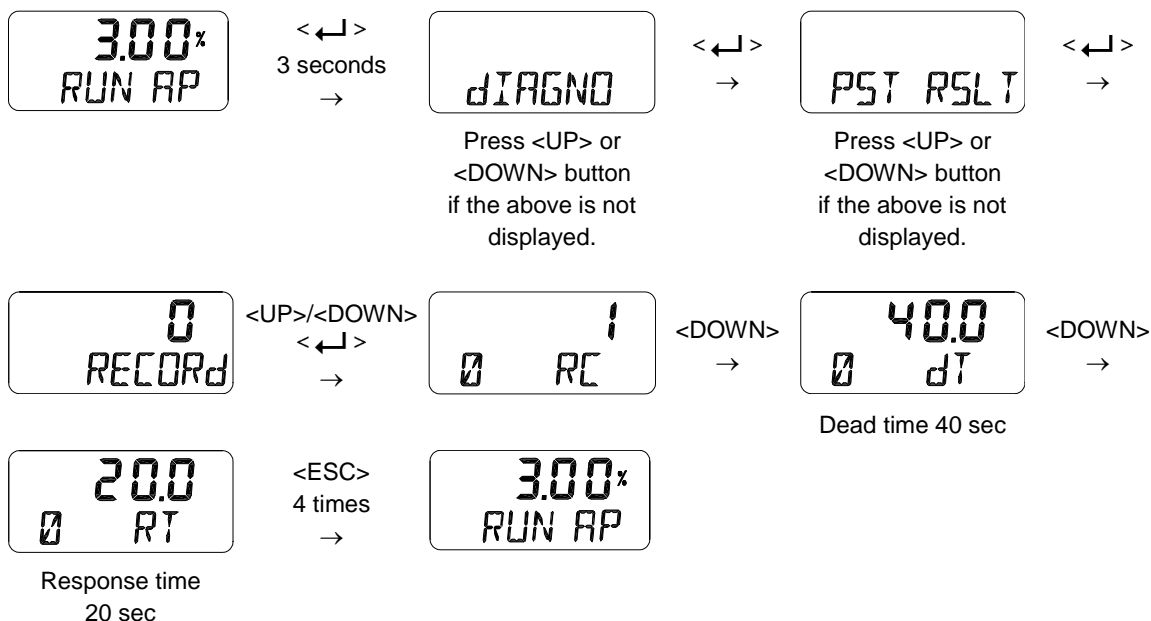

8.12.9 PST Configuration (PST CFG)

Parameter names	Abbreviation [unit]	Description
PST Interval	INTERVAL [days]	Sets time interval PST is triggered. Initial factory setting is 365 days.
PST Start Position	START PO [%]	Sets the start position to launch PST. Initial factory setting is 100 %.
PST Tolerance	TOL [%]	The allowable tolerance for the start position. PST Failure alarm is triggered as Out of Tolerance(OOT) when actual position exceeds the tolerance. Initial setting is 5%.
PST Target Position	TARGET [%]	Target position. Initial factory setting is 90%.
PST Hold Time	HOLD TM [sec]	Sets hold time after target position ($\pm 2\%$) is reached Initial factory setting is 5 sec.
PST Limit Time	LIMIT TM [sec]	PST Failure alarm is triggered as Limit Time Over (LTO) when target position is not reached within LIMT TM after starting PST. Initial factory setting is 10 sec.
PST Ramp up Rate	RAMP UP [%/sec]	Sets ramp rate when the valve moves from the target position to the start position. Initial factory setting is oFF.
PST Ramp down Rate	RAMP dN [%/sec]	Sets ramp rate when the valve moves from the start position to the target position. Initial factory setting is oFF.
Remaing PST Time	NEXT PST[days.hrs]	Based on the current time, the remaining time to start PST is displayed by Days and Time.

Graph below shows PST target position (TP) and actual position (AP) when applying PST Start Position 100%, Target Position 90%, Hold Time 10 sec, PST Ramp up Rate 0.5%/sec, PST Ramp down Rate 0.5%/sec.



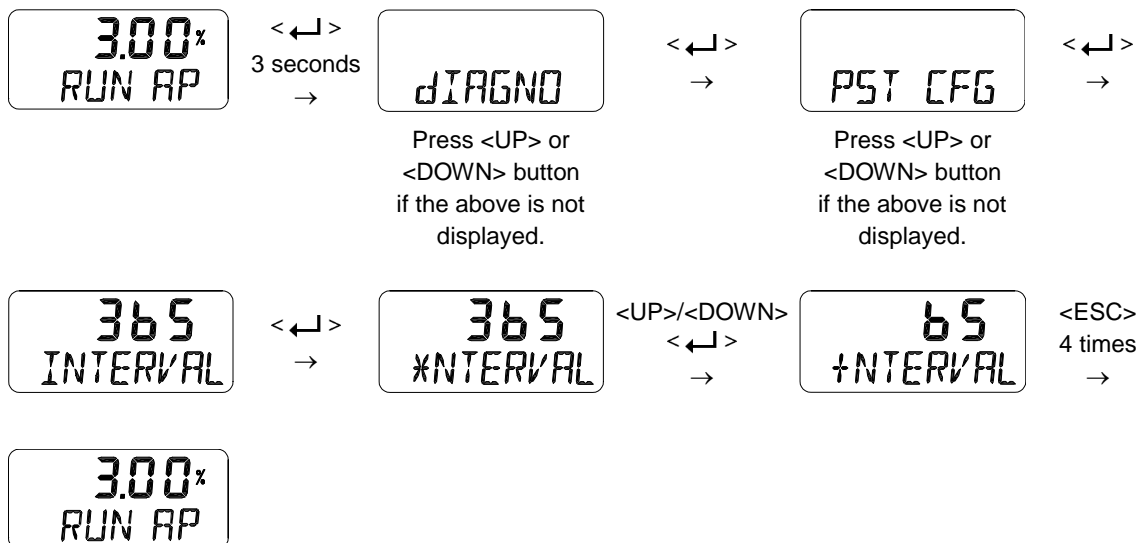

8.12.10 Run PST (PST NOW)

PST NOW is used to perform Partial Stroke Test promptly in accordance with the conditions set in 8.12.9.

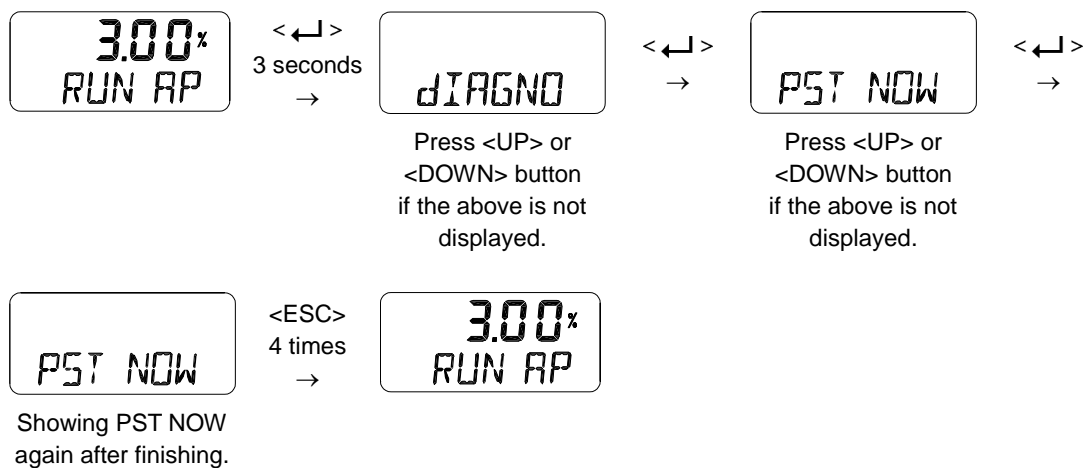

8.12.11 Periodic PST Test (PST Schedule, PST SCHd OFF / on)

When PST SCHd is set to ON, the Partial Stroke Test is executed regularly under the conditions set in 8.12.9 above. For example, PST is performed every 365 days when PST Interval is set to 365 days. The initial factory setting is OFF.

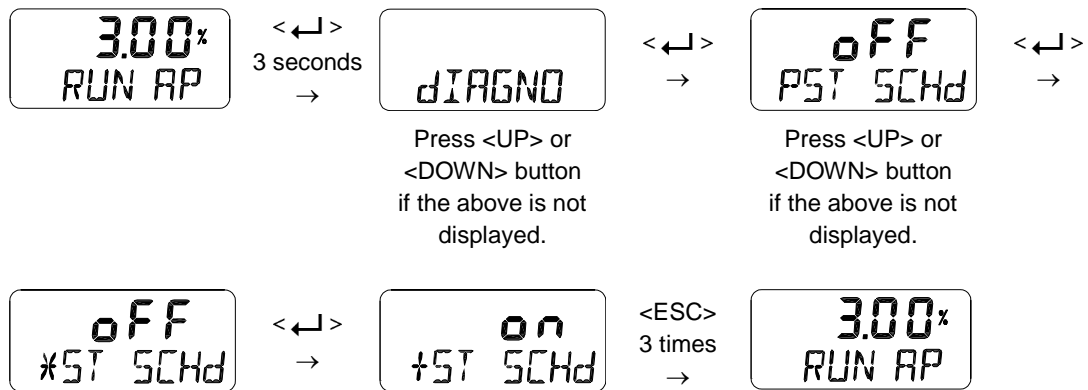

8.13 Position information (INFO)

The diverse Positioner information is provided in the INFO Mode.

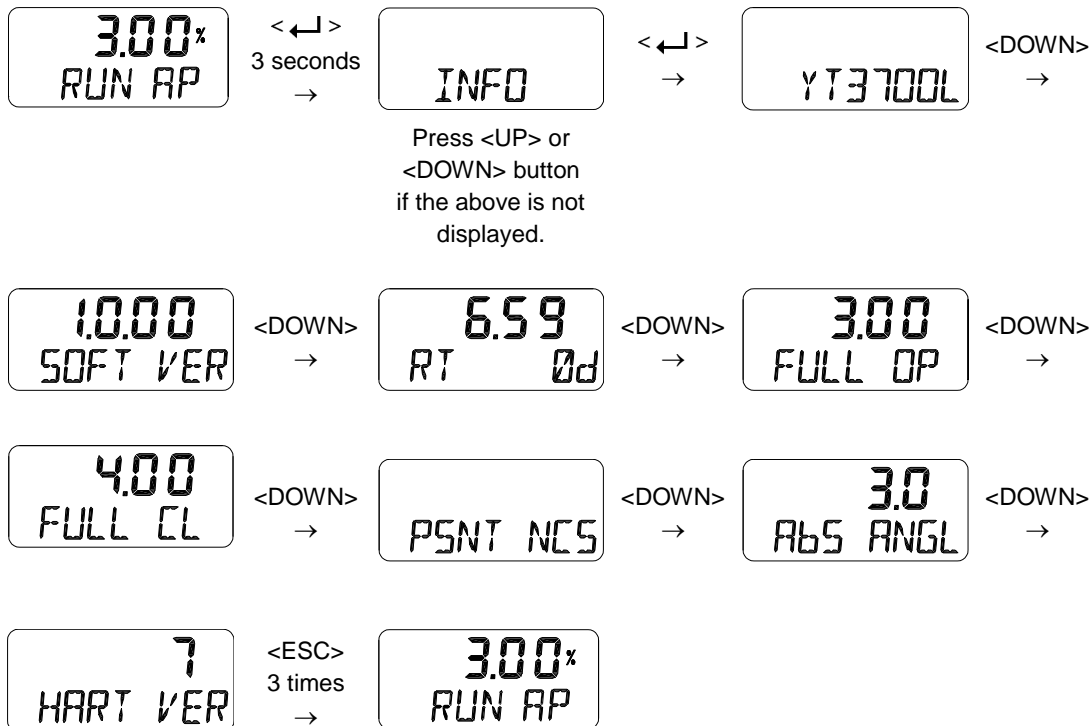

LCD display	Description
YT3700L	Model Name
1.0.00 SOFT VER / 2019MA21	Software Version [SOFT VER] "1.0.00" Software Input date : "2019 MA 21" At SOFT VER status if <← > button is pressed, the date will be displayed and then if <← > button is pressed again, SOFT VER is displayed again.
4.18 RT 0d	Run Time [RT] Total usage time of the product Upper "4.18" indicates 4 hours and 18 minutes. Lower "0d" indicates days used. Interval to store time is one minute.
3.12 FULL OP	Upward Full Stroke Time [FULL OP] This value is stored automatically after executing AUTO 2 calibration, and indicates the time in seconds it takes for the valve to fully open from fully closed.
2.97 FULL CL	Downward Full Stroke Time [FULL CL] This value is stored automatically after executing AUTO 2 calibration, and indicates the time in seconds it takes for the valve to fully closed from fully open.
PSNT NCS	Position Sensor Type [PSNT] Potentiometer [PTN] Non-Contact Sensor [NCS]
AbS ANGL	Absolute Position in Angle [ABS ANGL].
HART VER	HART Protocol Revision [HART VER]

8.14 Status and Alarm Code

The status and alarm codes can be displayed on the LCD screen as required. Refer to the table below to check the status and alarm codes, and then take the appropriate action. (See 8.5 Configuration and Operation)

Alarm Code	Abbreviation	Status / Alarm name	Description or proposed actions
0	LOPA	Local Operating Active	It indicates the positioner is being operated by manual operation.
1	CALR	Auto Calibration Running	It is active when auto-calibration is in progress.
2	DIGR	Diagnostics Running	It is active when diagnosis test such as Step Response Test, Stroke Time Test, and Trace Test is in progress.
3	PSTR	PST Running	It is active when Partial Stroke Test is in progress.
4	PSNH	Position Sensor Hi Limit	Position sensor is out of range. Check the installed state if it happened during operation.
5	PSNL	Position Sensor Lo Limit	Position sensor is out of range. Check the installed state if it happened during operation.
6	NVMF	Critical NVM Defect	It is active if there is a failure associated with NVM (Nonvolatile Memory). Initialize the positioner using Default function and then AUTO 2 calibration. If it is repeated, replace the electronics board by contacting the manufacturer or manufacturer's representative.
7	NVMW	Non-Critical NVM Defect	
8	CYCC	Cycle Count Limit	It is active if the accumulated cycle counter exceeds Cycle Count Limit. Check the condition of the valve and then determine if it is replaced or not. If there is no problem with the valve, increase the Cycle Count Limit.
9	TVLA	Travel Accumulator Limit	It is active if the travel accumulator exceeds Travel Accumulator Limit. Check the condition of the valve and then determine if it is replaced or not. If there is no problem with the valve, increase the Travel Accumulator Limit.
10	OPRC	Operating Count Limit	It is active if the number of operations for I/P converter exceeds has exceeded Operating Count Limit. Determine if the setting is appropriate or the I/P converter is replaced or not.
11	TMPH	Temperature Hi Limit	It is active if internal temperature exceeds Temperature Hi Limit. If the set temperature exceeds the maximum temperature allowed by the product, the product may not operate if the ambient temperature around the positioner is not lowered.
12	TMPL	Temperature Lo Limit	It is active if internal temperature is lower than Temperature Lo Limit. If the set temperature is lower than the minimum temperature allowed by the product, the product may not operate if the ambient temperature around the positioner is not raised.

Alarm Code	Abbreviation	Status / Alarm name	Description or proposed actions
13	TVLH	Travel Hi Limit	It is active when the travel exceeds Travel Hi Limit.
14	TVLL	Travel Lo Limit	It is active when the travel falls below Travel Lo Limit.
15	dVTO	Deviation Time Out	It is active when actual deviation greater than the preset Deviation persists longer than the preset Deviation Time. Check if the setting is appropriate or if there is no problem with the friction of valve/actuator, pneumatic leaks, insufficient supply pressure.
16	PSTF	PST Failure	It is active when Partial Stroke Test has failed. Remove the cause of the fail after checking the response code of the PST.
17	TSNF	Temperature Sensor Defect	It is active when internal temperature sensor has failed. If it is repeated, replace the electronics board by contacting the manufacturer or manufacturer's representative.
18	PSNF	Position Sensor Defect	It is active if there is a problem with the position feedback sensor inside the positioner. If it is repeated, replace the electronics board by contacting the manufacturer or manufacturer's representative.
19	ABdS	Abnormal Drive Signal	It is active if there is a problem with I/P converter. If it is repeated, replace the electronics board by contacting the manufacturer or manufacturer's representative.
21	IVLH	Integral Value Hi Limit	It is active if the integrator output is saturated at Integral Value Hi Limit. It may happen when the valve/actuator has a high friction.
22	IVLL	Integral Value Lo Limit	It is active if the integrator output is saturated at Integral Value Lo Limit. It may happen when the valve/actuator has a high friction.
23	TVCH	Travel Cutoff Hi Limit	It is active when the travel exceeds the available high stroke of the valve/actuator. The available stroke is already set during auto calibration. The event is not created when Tight Shut Open is used. Aging of the valve / actuator assembly or problem in the positioner sensor.
24	TVCL	Travel Cutoff Lo Limit	It is active when the travel is below the available low stroke of the valve/actuator. The available stroke is already set during auto calibration process. The event is not created when Tight Shut Close is used. Aging of the valve / actuator assembly or problem in the positioner sensor.
28	NCAL	Not Calibrated	It is active when auto-calibration has not done after installation. Perform AUTO 2 calibration after checking if the installed state is good.
29	CALF	Auto Calibration Failure	It is active when auto-calibration has failed. Retry auto-calibration after checking if there is no problem with installed state such pneumatic leaks, lever position and others.

30	ZPdR	Zero Point Drift	It is active if zero point or endpoint exceeds the settings. The valve seat may be damaged or there may a linkage problem associated with lever.
31	EPdR	EndPoint Drift	

Alarm Code	Abbreviation	Status / Alarm name	Description or proposed actions
32	STAK	Stack Overflow	Replace the electronics board by contacting the manufacturer or manufacturer's representative.
33	COMM	Communication Error Count Limit	It is active if the HART related communication errors exceed the setting. Check the cable connections or make sure that the environment is susceptible to noise.
34	FCLC	Full Close Count Limit	It is active if the valve exceeds Full Close Count Limit.
35	FOPC	Full Open Count Limit	It is active if the valve exceeds Full Open Count Limit.
36	LPCH	Loop Current Hi Limit	It is active if the input current exceeds 20.5 mA.
37	LPCL	Loop Current Lo Limit	It is active if the input current falls below 3.8 mA.
38	DI0S	Digital Input Status	It is active when the digital input port has changed its status.
39	DO0S	Digital Output Status	It is active when the digital output port has changed its status.
40	DIGF	Diagnostics Failure	It indicates that the diagnosis test such as Large Step Test, Normal Step Test, Small Step Test, Stroke Time Test and Trace Test has failed.
145	VARA	Device Variable Alert	It is active when one of the internal variables are out of range.
144	MNTR	Maintenance Required	It is active when more than one of alarms assigned to "Maintenance Required" have happened. Remove the cause of the alarm after checking it.
147	FAIL	Failure	It is active when more than one of alarms assigned to "Failure" have happened. Remove the cause of the alarm after checking it.
148	OUTS	Out of Specification	It is active when more than one of alarms assigned to "Out of Specification" have happened. Remove the cause of the alarm after checking it.
149	FUNC	Function Check	It is active when more than one of alarms assigned to "Functional Check" have happened. Remove the cause of the alarm after checking it.

9 Main Software Map

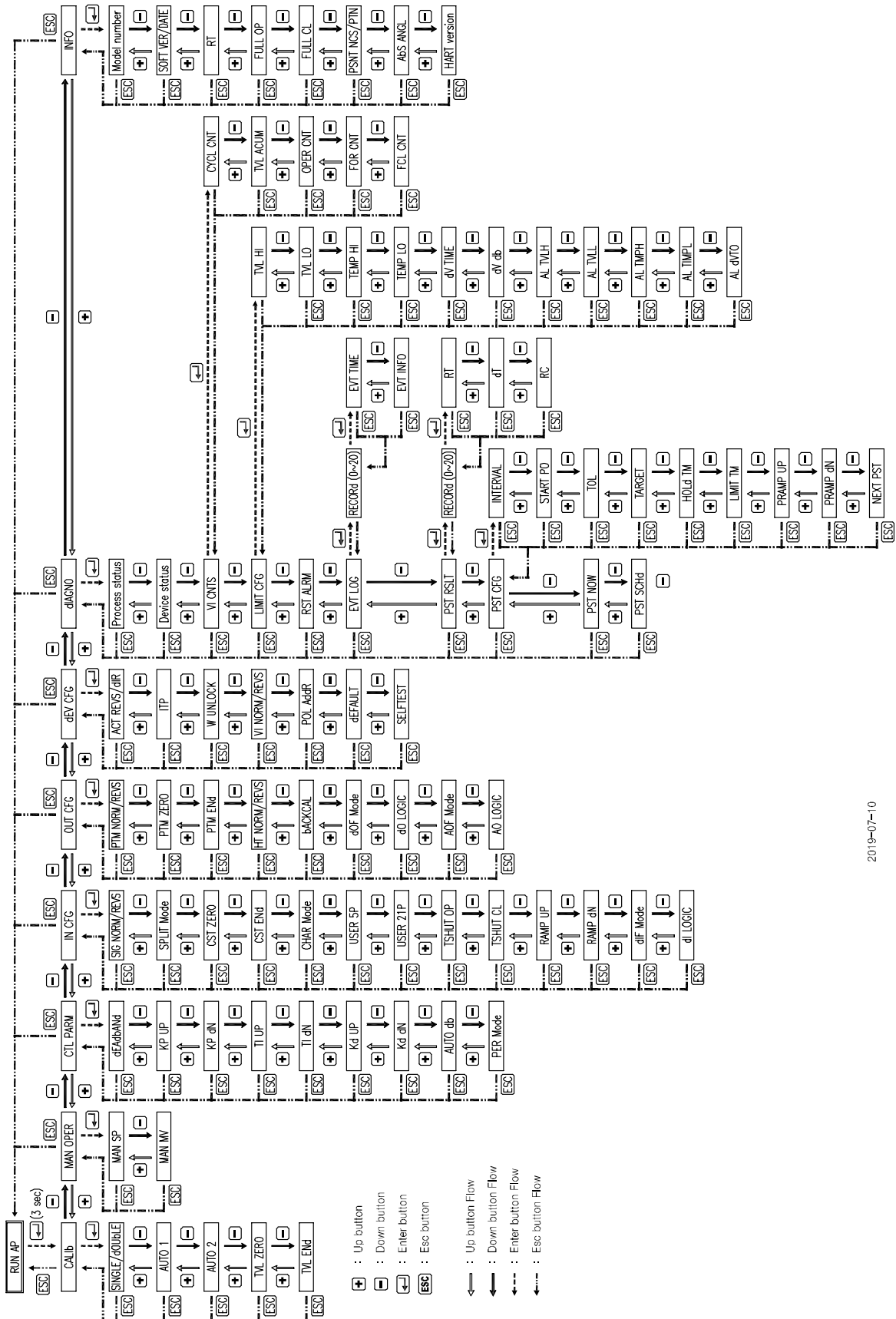

2019-07-10

Manufacturer: Rotork YTC Limited

Address: 81, Hwanggeum-ro, 89 Beon-gil, Yangchon-eup, Gimpo-si, Gyeonggi-do, South Korea

Postal code: 10048

Tel: +82-31-986-8545

Fax: +82-70-4170-4927

Email: ytic.sales@rotork.com

Homepage : <http://www.ytc.co.kr>

Issued : 2020-01-02

Copyright © Rotork YTC Limited. All Rights Reserved.