



Backwater, Sewage & Sump Pump Specialty Valves



PRODUCT

Contact Spears® for any Information not found.

Valves Product Sewer Disconnect



Spears® Sewer Disconnect functions as both cleanout and disconnect device, plus helps prevent sewage backup during hurricanes and floods. Complete unit consists of body and plunger (sold separately - both parts are required for proper use). The plunger can be screwed into the body to block solids waste flow. The plunger should be removed from the body and stored when not in use to prevent accidental closing (i.e., from ground vibration, etc.).



- Connects directly to 4" or 6" SDR-35 (or any ASTM D3034/D2729) PVC Sewer Pipe.
- Easily adapted to 4" or 6" Schedule 40 PVC Drainage Pipe with addition of IPS x Sewer Adapters, Socket x Spigot, Spears® part no. 3729-04013IXS for 4" or 3729-06013IXS for 6".
- User-supplied standpipe can be installed to grade using PVC Sewer Pipe connected to the body branch socket and a Sewer Cap to close off (Spears® part no. 4047-040 for 4" or 4047-060 for 6"). Optionally, user-supplied Schedule 40 Pipe can be used for standpipe with addition of a Schedule 40 DWV Socket Coupling (Spears® part no. P100-040 for 4" or P100-060 for 6") and Cap (Spears® part no. P116-040 for 4" or P116-060 for 6").
- T-handle for Plunger operation can be easily fabricated from user-supplied 1" Schedule 40 Pipe and Tee fitting (Spears® part no. 401-010).

Note - the unit restricts flow by approximately 85%. As a result, the unit must be located in the sewer line where solids are present. Full disconnect is not achieved without solids in the flow.

Auxiliary Components (Purchased Separately)

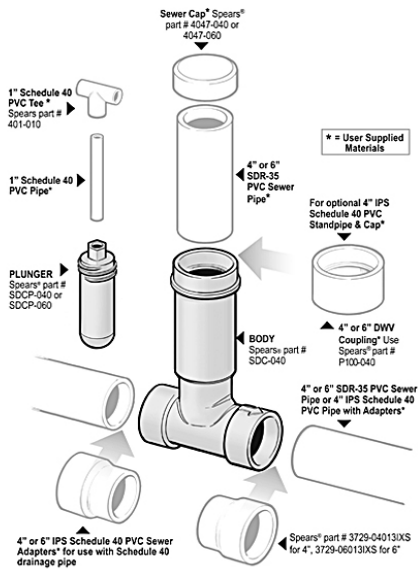

4" Basic Dimensions

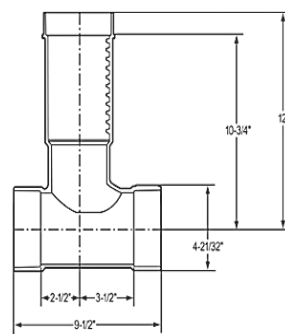

6" Basic Dimensions

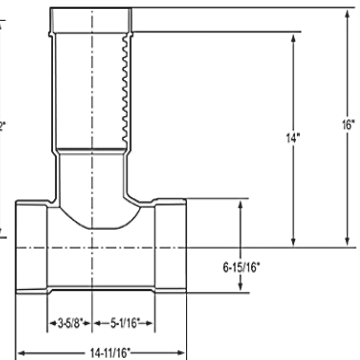

Sewer Disconnect

Sewer Disconnect Body

Part Number	Size	Std Pk	Mstr Ctn	Prod Code	MSRP
-------------	------	--------	----------	-----------	------

Sewer Socket X Sewer Socket.

Requires Purchase of SDCP-040 or SDCP-060 Plunger

SDC-040	4	6	0	055	89.21
SDC-060	6	2	0	055	135.81

Sewer Disconnect Plunger

Part Number	Size	Std Pk	Mstr Ctn	Prod Code	MSRP
-------------	------	--------	----------	-----------	------

For Use With Sewer Disconnect Body Purchased Separately.

Requires Purchase of SDC-040 or SDC-060 Body

SDCP-040	4	12	0	055	30.73
SDCP-060	6	6	0	055	59.96

Optional IPS x SEWER Adapter

IPS Socket x Sewer Spigot for adapting Sewer Disconnect Body to Schedule 40 drainage pipe



3729-04013IXS	4	1	90	399	20.42
3729-06013IXS	6	1	15	399	43.09



Valves Product Utility Backwater Valve

Utility Backwater Valve



Spears® Utility Backwater Valves feature an easily serviceable and replaceable Flapper Assembly with extendable access using standard piping components. Designed for direct solvent cement connection to ASTM D 2665 DWV drainage pipe or any other IPS size pipe. Spears® IPS x Sewer adapters easily convert valve to ASTM D 3034 SDR 35 Sewer Pipe. Backwater Valves conform to requirements of ASME/ANSI A112.14.1 Utility

Backwater Valves are designed to prevent backflow in numerous applications where easy service access for maintenance and cleaning is needed. Excellent for use in sanitary or storm sewer drainage systems to prevent waste back up due to inadequate drainage, for balancing multi-level ponds, aquaculture features or storage tank systems, and many other applications. Spears® Utility Backwater Valve has been engineered for easier installation with included Extension Kit Adapter components for use with User-Supplied Schedule 40 or Class 125 Extension Riser pipe cut to desired length. Utility Backwater Valve package comes with 50 psi (115 feet of head) rated Extension Adapters. Optional Adapter Kits available in 100 psi (232 feet of head) rating. Can also use User-supplied equivalent adapter components.

- Replaceable internal flapper assembly.
- Extension Kit Adapter components allow easy use with assembly user supplied pipe cut to desired length.
- Direct Valve Connection to ASTM D 2665 PVC DWV or other IPS size pipe. Spears® IPS DWV x Sewer & Drain Adapter are available for connection to ASTM D 3034 & ASTM D 2729 Sewer pipe.
- Standard Valve Extension Adapters Pressure Rated to 50 psi (115 feet of head) @ 73°F (23°C) - Optional 100 psi Adapter (232 feet of head) available.
- Conforms to ASME/ANSI A112.14.1 for Backwater Valves.

Part Number	Size	Std Pk	Mstr Ctn	Prod Code	MSRP
-------------	------	--------	----------	-----------	------

Utility Backwater Valve w/Extension Adapters

Valve Package includes Body, Flapper Assembly and Extension Adapters (female thread & male thread plug) with 50 psi Extension Adapters Rating 100 psi Extension Adapter Available.



Requires User-Supplied 6" (for 4" valves) or 8" (for 6" valves) from Schedule 40 or Class 125 Riser Extension Pipe cut to desired length and 1" or 1-1/4" Internal Extension Pipe

SML-3	3	1	0	055	71.48
SML-4	4	1	0	055	80.37
SML-6	6	1	0	055	108.42

Part Number	Size	Std Pk	Mstr Ctn	Prod Code	MSRP
-------------	------	--------	----------	-----------	------

Utility Backwater Valve Only Includes Valve Body & Flapper Assembly

Socket x Socket

Requires used of either 50 psi or 100 psi Extension Kit, or use of User-supplied equivalent components



SML-3XP-A	3	1	0	055	49.42
SML-4XP-A	4	1	0	055	54.44
SML-6XP-A	6	1	0	055	80.63

Utility Backwater Valve Extension Adapter Kit

Select 50 psi or 100 psi Kit

Kit includes Female Threaded Cleanout Adapter and Male Threaded Plug for use with User-Supplied 6" (for 4" valves) or 8" (for 6" valves) from Schedule 40 or Class 125 Riser Extension Pipe



Note: 50 psi Kits have DWV Cleanout Plugs, 100 psi kits have Schedule 40 Threaded Plugs. User-supplied equivalent components can also be used.

SML4XP-A-EK50	3" & 4" 50 psi	1	0	055	41.48
SML4XP-A-EK100	3" & 4" 100 psi	1	0	055	85.55
SML6XP-A-EK50	6" 50 psi	3	0	055	58.18
SML6XP-A-EK100	6" 100 psi	3	0	055	106.78

Utility Backwater Valve Flapper Replacement Kit

Kit include Flapper Assembly For Repair or Replacement



SML4XP-A-FRK	3" & 4"	1	10	055	33.74
SML6XP-A-FRK	6"	1	5	055	40.09

IPSX Sewer Adapter

IPS DWV Spigot x Sewer Hub



Adapts IPS DWV Valve Socket to Sewer Pipe

P118-030	3	25	0	051	6.53
P118-040	4	10	0	051	7.06
3729-06031XS	6	1	4	399	62.06

Valves Product
Industrial PVC Backwater Valves



Industrial PVC Backwater Valves

Backwater Valves are designed to prevent backflow in numerous applications where easy service access for maintenance and cleaning is needed. Excellent for use in sanitary or storm sewer drainage systems to prevent waste back up due to inadequate drainage, for balancing multi-level ponds, aquaculture features or storage tank systems, and many other applications. Spears® Backwater Valve has been engineered for improved function and easier service, especially in buried service with use of optional Service-Access Extension available either preassembled with valve or as an add-on kit.

- Replaceable internal flapper assembly with EPDM Seat.
- Service-Access Extension available either preassembled with valve, as an add-on kit, or as valve & extension kit components with user supplied pipe.
- Direct Connection to ASTM D 2665 PVC DWV or other IPS size pipe. Spears® fabricated IPS x Sewer Adapters or DWV x Sewer & Drain Adapter Bushings are available for connection to ASTM D 3034 & ASTM D 2729 Sewer pipe.
- Pressure Rated to 43 psi (100 feet of head) @ 73°F (23°C).
- All extension kits can be cut shorter for custom application.
- Conforms to ASME/ANSI A112.14.1 for Backwater Valves.

PVC Backwater Valves



Backwater Valves - Valve Only

Part Number	Size	Std Pk	Mstr Ctn	Prod Code	MSRP
Socket x Socket					
S275P	2	1	12	055	72.49
S375P	3	2	0	055	72.64
S475P	4	1	0	055	80.47
S675P	6	1	0	055	342.86

PVC Backwater Valves with Extension Kit to Premade Length



Backwater Valves with Extension Kit to Premade Length

Part Number	Size	Std Pk	Mstr Ctn	Prod Code	MSRP
Socket x Socket					
Assembled with Extension					
S275P-120 ¹	2X12HT	1	0	055	218.68

Backwater Valves with Extension Kit to Premade Length

(continued)

Part Number	Size	Std Pk	Mstr Ctn	Prod Code	MSRP
Socket x Socket					
S275P-160 ¹	2X16HT	1	0	055	235.21
S275P-200 ¹	2X20HT	1	0	055	251.75
S275P-240 ¹	2X24HT	1	0	055	268.29
S275P-360 ¹	2X36HT	1	0	055	281.80
S275P-480 ¹	2X48HT	1	0	055	309.71
S375P-120 ¹	3X12HT	1	0	055	218.68
S375P-160 ¹	3X16HT	1	0	055	235.21
S375P-200 ¹	3X20HT	1	0	055	251.75
S375P-240 ¹	3X24HT	1	0	055	268.29
S375P-360 ¹	3X36HT	1	0	055	281.80
S375P-480 ¹	3X48HT	1	0	055	309.71
S475P-120 ¹	4X12HT	1	0	055	284.05
S475P-160 ¹	4X16HT	1	0	055	306.44
S475P-200 ¹	4X20HT	1	0	055	326.82
S475P-240 ¹	4X24HT	1	0	055	348.49
S475P-360 ¹	4X36HT	1	0	055	366.01
S475P-480 ¹	4X48HT	1	0	055	402.20
S675P-120 ¹	6X12HT	1	0	055	596.46
S675P-160 ¹	6X16HT	1	0	055	643.52
S675P-200 ¹	6X20HT	1	0	055	686.33
S675P-240 ¹	6X24HT	1	0	055	731.94
S675P-360 ¹	6X36HT	1	0	055	768.61
S675P-480 ¹	6X48HT	1	0	055	844.62

¹ - Size designates nominal valve size x extension height (HT-top of valve to top of extension, inches)

PVC Service-Access Extension Kit Only to Premade Length



PVC Service-Access Extension Kit: includes factory assembled internal flap assembly, assembly extension pipe, and external extension housing with top access adapter. Requires solvent cement assembly to existing valve and uses existing threaded Access Plug. Standard Extensions are available in convenient increments of 12", 16", 20", 24", 36", and 48" (measured from top of valve to top of extension). Contact Spears® for MSRP on custom cut lengths. All extension kits can be cut shorter in the field for custom fits prior to cementing access adapter in place.

Service-Access Extension Kit Only to Premade Length

Part Number	Size	Std Pk	Mstr Ctn	Prod Code	MSRP
SAEK-020-120 ¹	2X12HT	1	0	055	68.20
SAEK-020-160 ¹	2X16HT	1	0	055	70.16
SAEK-020-200 ¹	2X20HT	1	0	055	72.01



Valves Product
Industrial PVC Backwater Valves

Industrial PVC Backwater Valves

Service-Access Extension Kit Only to Premade Length (continued)

Part Number	Size	Std Pk	Mstr Ctn	Prod Code	MSRP
SAEK-020-240 ¹	2X24HT	1	0	055	75.44
SAEK-020-360 ¹	2X36HT	1	0	055	79.03
SAEK-020-480 ¹	2X48HT	1	0	055	82.89
SAEK-030-120 ¹	3X12HT	1	0	055	73.96
SAEK-030-160 ¹	3X16HT	1	0	055	83.49
SAEK-030-200 ¹	3X20HT	1	0	055	88.44
SAEK-030-240 ¹	3X24HT	1	0	055	99.67
SAEK-030-360 ¹	3X36HT	1	0	055	117.91
SAEK-030-480 ¹	3X48HT	1	0	055	139.45
SAEK-040-120 ¹	4X12HT	1	0	055	210.62
SAEK-040-160 ¹	4X16HT	1	0	055	225.89
SAEK-040-200 ¹	4X20HT	1	0	055	249.47
SAEK-040-240 ¹	4X24HT	1	0	055	270.97
SAEK-040-360 ¹	4X36HT	1	0	055	346.77
SAEK-040-480 ¹	4X48HT	1	0	055	422.58
SAEK-060-120 ¹	6X12HT	1	0	055	309.11
SAEK-060-160 ¹	6X16HT	1	0	055	379.99
SAEK-060-200 ¹	6X20HT	1	0	055	422.46
SAEK-060-240 ¹	6X24HT	1	0	055	465.40
SAEK-060-360 ¹	6X36HT	1	0	055	600.73
SAEK-060-480 ¹	6X48HT	1	0	055	734.43

¹ - Size designates nominal valve size x extension height (HT-top of valve to top of extension, inches)

PVC Backwater Valve with Extension Components



Backwater Valve with Extension Components

Part Number	Size	Std Pk	Mstr Ctn	Prod Code	MSRP
-------------	------	--------	----------	-----------	------

Socket x Socket

Must be assembled with user supplied pipe (see Table 1)

S275P-AK	2	1	8	055	106.81
S375P-AK	3	1	0	055	106.81
S475P-AK	4	1	0	055	124.96
S675P-AK	6	1	0	055	442.46

PVC Backwater Valve Extension Components Only



Backwater Valve Extension Components Only

Part Number	Size	Std Pk	Mstr Ctn	Prod Code	MSRP
-------------	------	--------	----------	-----------	------

Must be assembled with user supplied pipe (see Table 1)

S275P-ECK	2	1	8	055	56.88
S375P-ECK	3	1	8	055	56.88
S475P-ECK	4	1	0	055	74.12
S675P-ECK	6	1	0	055	155.73

Table 1: User Supplied Pipe Requirements For Use With Extension Components

Valve Size	Acceptable RISER Pipe Types for User-Supplied Pipe	Acceptable HANDLE Pipe
2"	4" Class 125 PVC PIPE 4" Sch 40 PVC PIPE	Use any 3/4" IPS plastic pipe ¹
3"	5" Class 125 PVC PIPE 5" Sch 40 PVC PIPE ³ 6" D3034 (SDR 35) PVC SEWER PIPE ²	
4"	8" Class 125 PVC PIPE 8" Sch 40 PVC PIPE	
6"	10" Class 125 PVC PIPE 10" Sch 40 PVC PIPE	

Note 1: Riser and Handle pipe are *not* the same length. Sch 40 and/or Sch 80 pipe as well as ABS may be used. Special cement must be used to join PVC to ABS.

Note 2: When 6" SDR35 pipe is used, adapter fits pipe inside diameter.

Note 3: DO NOT use Sch 80 for 3" Riser pipe.

Valves Product
Industrial PVC Backwater Valves & Sump Pump Swing Check Valves



Industrial PVC Backwater Valves

Sump Pump Swing Check Valves

Industrial Backwater Valve Flapper Repair Kit



Backwater Valve Flapper Repair Kit

Part Number	Size	Std Pk	Mstr Ctn	Prod Code	MSRP
Complete Flapper Assembly replacement					
S275P-FRK	2	1	10	055	42.33
S375P-FRK	3	1	10	055	53.39
S475P-FRK	4	1	10	055	62.18
S675P-FRK	6	1	5	055	110.73

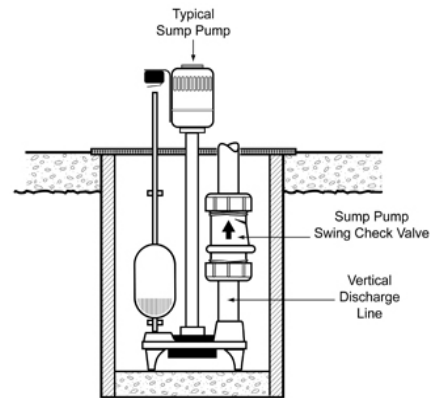

PVC Backwater Valve Metric Adapters



Backwater Valve Metric Adapters

Part Number	Size	Std Pk	Mstr Ctn	Prod Code	MSRP
Metric Socket x ASTM Spigot					
S275MA-063	63mm X 2	50	0	055	18.76
S375MA-090	90mm X 3	25	0	055	20.16
S475MA-110	110mm X 4	10	0	055	23.87
S675MA-160	160mm X 6	4	0	055	55.12

- Specifically Designed for Use on Sump Pump Discharge Lines (See Illustration)
- Includes Compression End Connectors with Buna-N Gaskets for Use on Either 1-1/4" or 1-1/2" Pipe
- All Plastic Construction with Elastomer Seals - No Metal Parts
- Angled Seat and Weighted Flapper for Low-Pressure Seal
- Suitable for Vertical Up-flow or Horizontal Installations

Pressure Rating @ 73°F (23°C), Water
 Full Flow (open) 150 psi
 Back Pressure (closed) 75 psi

Maximum Service Temperature
 140°F (60°C)

Temperature/Pressure De-ratings Apply

General Installation Information: Sump Pump Swing Check Valves may be installed in either vertical up-flow (see illustration) or horizontal positions on pump discharge line. Check valves **MUST** be installed with the valve's FLOW arrow pointing in the direction of the flow. In horizontal installations, the designated side must be positioned "up." Do Not install Check Valve upside down.

PVC Sump Pump Swing Check Valve

Part Number	Size	Std Pk	Mstr Ctn	Prod Code	MSRP
Compression Ends					
Buna-N Gaskets included for both 1-1/4" & 1-1/2" pipe					
S1400-15	1-1/2" & 1-1/4"	16	0	026	23.08



Valves Product
Swing Check Ball Valves & Quiet Check Valves

Swing Check Ball Valves



- One-piece Combination for Applications Requiring In-line Ball Valve and Check Valves
- Compact, Space-Saving Design
- True Union Design Allows Easy Service and Cleaning
- High Grade EPDM Seals
- Replaceable PTFE HDPE Ball Valve Seats
- Safety-Blocked™ Seal Carrier on Ball Valve
- Replaceable Sealed Check Valve Cartridge
- Suitable for Horizontal or Vertical Up-flow Installations
- Socket End Connections

Pressure Rating @ 73°F (23°C), Water
 Full Flow (open) 150 psi
 Back Pressure (closed) 75 psi

Maximum Service Temperature
 140°F (60°C)

Temperature/Pressure De-ratings Apply

General Installation Information: Swing Check Ball Valves are designed for horizontal installations, but may be installed in an up-flow only vertical position. The Check Valve portion **MUST** be installed with the valve's FLOW arrow pointing in the direction of flow and with the designated side up in horizontal installations. Do Not install Check Valve upside down. The Ball Valve portion may be rotated and installed in any position. Flow velocity should not exceed 5 ft./sec. Minimum opening pressure is less than 0.5 psi.

PVC Swing Check Ball Valve

Part Number	Size	Std Pk	Mstr Ctn	Prod Code	MSRP
-------------	------	--------	----------	-----------	------

Socket x Socket

7622-015	1-1/2	10	0	026	52.26
7622-020	2	6	0	026	75.00

Quiet Check Valves

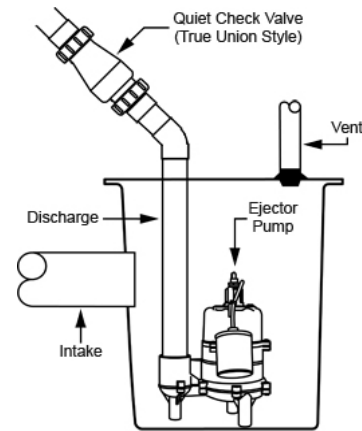

Typical Application

- Designed to Provide Quiet Operation in Sump Pump or Sewage Ejector Pump Systems.
- Spring Controlled Rate of Closing Prevents Slamming and Eliminates Noise.
- Includes Both True Union Sockets for Easy Servicing and Direct Socket Connection for Installation in Confined Space.
- 2" Size for Sewage Ejector Systems, 1-1/2" Size for Sump Pump Effluent Systems.

Pressure Rating @ 73°F (23°C), Water
Full Flow (open) 150 psi
Back Pressure (closed) 75 psi
Maximum Service Temperature 140°F (60°C)
 Temperature/Pressure De-ratings Apply

General Installation Information: Install check valve 12"-18" above pump discharge, or as recommended by pump system manufacturer. Be sure check valve installation complies with local codes. Valve may be installed in either vertical up-flow or horizontal positions on pump discharge line. Check valves **MUST** be installed with the valve's FLOW arrow pointing in the direction of the flow. In horizontal installations, the designated side must be positioned "up."

PVC Quiet Check Valve

Part Number	Size	Std Pk	Mstr Ctn	Prod Code	MSRP
-------------	------	--------	----------	-----------	------

Soc x Soc

True Union or Direct Socket End Connection

8622-015	1-1/2	12	0	026	51.71
8622-020	2	10	0	026	73.89