

CIRCUIT BALANCING VALVES

CB800 CIRCUIT BALANCING VALVES

The CB800 valve serves 5 functions: throttling; measuring differential pressure; draining; filling; and positive shutoff. It is rated at 300 psi (20.7 bar) at 300° F (150°C). The valve is made of dezincification resistant brass and bronze components. Threaded and solder connections are available for sizes ½" (DN 15) – 2" (DN 50) sizes with bronze bodies. Flanged (125#) and grooved connections are available for sizes 2½" (DN 65) – 12" (DN 300) with cast iron bodies.

The Y-pattern provides low pressure drop and the globe style valve allows for precise throttling. The easy to adjust digital/vernier handwheel gives a minimum of 70 unique handwheel positions. The handwheel and test ports are located on one side and the test ports are on one end for easy access. There is a built-in memory stop to ensure the setting can be returned to a balanced position after shutoff. The self-sealing pressure/temperature test ports use standard insertion probes to eliminate additional components.

The circuit balancing valve is installed with flow in the direction of the arrow, and may be in the horizontal or vertical position. The handwheel can be positioned up or down, or on either side.



Tech Data: G450

MATERIAL SPECIFICATIONS

Body

- Sizes ½" (DN15) to 2" (DN50) solder or NPT threaded connection — brass resistant to dezincification (DZR)
- Sizes 2½" (DN16) to 12" (DN300), grooved or flanged connection — Cast Iron conforming to ASME/ANSI B16.5

Valve Stem & Disc

- Brass Resistant to Dezincification (DZR)

O Ring

- EPDM E

Handwheel

- Thermoplastic

Valve Sizing

All balancing valves are sized to perform in a normal operation range between 25% and 100% of the full open position, at a minimum differential pressure between 1 to 3 ft. of water. It is recommended that for improved accuracy the valve is set to open 70%+.

When maximum flow is known but a pressure drop through the balancing valve is unknown, select a balancing valve for a maximum pressure drop of 2 ft. water (5.7 kPa) in the full open position as shown in the table to the right:

Accurate flow measurement requires that the velocity distribution near the balancing valve stays constant, regardless of the total flow through the pipe. Fittings, such as elbows and tees, disturb the normal flow profile which is established through straight pipe. Pumps create even greater disturbances. Failure to allow water flows around fittings and pumps to normalize can affect measuring accuracy by as much as 20% when the valve is in the fully open position. Minimum lengths (diameters, D) of straight pipe before and after the balancing valve prevent these errors. Valves are designed for vertical, horizontal or inclined installation.

Minimum Pipe Diameters from Fittings

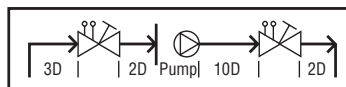

Flow		Size		Connection
GPM	(l/h)	Inches	(DN)	Swt thrd / Flng grv
0.5 - 4.1	(100 - 1000)	½	(15)	sweat thread
4.1 - 6.1	(1.0k - 1.5k)	¾	(20)	sweat thread
6.1 - 9.2	(1.5k - 2.3k)	1	(25)	sweat thread
9.2 - 20	(2.3k - 5.0k)	1-1/4	(32)	sweat thread
20 - 29	(5.0k - 7.2k)	1-1/2	(40)	sweat thread
29 - 40	(7.2k - 10k)	2	(50)	sweat thread
40 - 102	(10k - 25k)	2-1/2	(65)	flanged grooved
102 - 125	(25k - 31k)	3	(80)	flanged grooved
125 - 210	(31k - 50k)	4	(100)	flanged grooved
210 - 300	(50k - 76k)	5	(125)	flanged grooved
300 - 430	(76k - 108k)	6	(150)	flanged grooved
430 - 760	(108k - 190k)	8	(200)	flanged grooved
760 - 1350	(190k - 340k)	10	(250)	flanged grooved
1350 - 1500	(340k - 377k)	12	(300)	flanged grooved

CIRCUIT
BALANCING
VALVES

CIRCUIT BALANCING VALVES

Model CB800

Grooved End

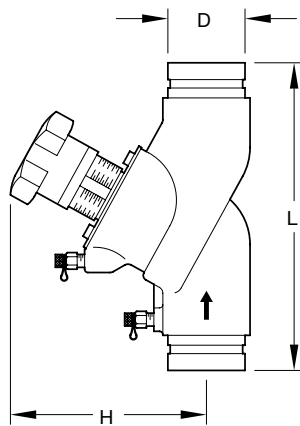

Size Inches	Connection	Nominal Dimensions			Approx. Weight Lbs. Kg.	PSI / °F PN / °C	Hand- wheel Turns
		L Inches mm	H Inches mm	D Inches mm			
2½	Groove	11.44	7.38	2.88	18.7	235/300	8.0
65		290,6	187,5	73,2	8,5	16/150	
3	Groove	12.25	8.00	3.50	27.5	235/300	8.0
80		311,2	203,2	88,9	12,5	16/150	
4	Groove	13.75	9.44	4.50	45.1	235/300	8.0
100		349,3	239,8	114,3	20,5	16/150	
5	Groove	15.75	11.13	5.56	70.4	235/300	8.0
125		400,0	282,7	141,2	32	16/150	
6	Groove	18.88	11.25	6.63	95.7	235/300	8.0
150		479,6	285,8	168,4	43,5	16/150	
8	Groove	23.63	18.44	8.63	255.2	235/300	12.0
200		600,2	468,4	219,2	116	16/150	
10	Groove	28.75	18.88	10.75	376.2	235/300	12.0
250		730,3	479,6	273,1	171	16/150	
12	Groove	33.44	20.25	12.75	519.2	235/300	12.0
300		849,4	514,4	323,9	136	16/150	

Flanged End

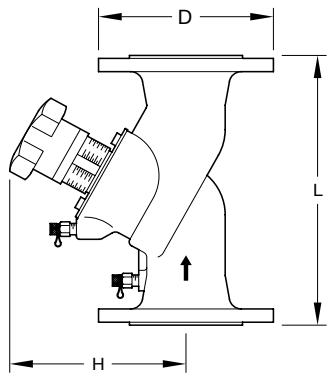

Size Inches	Connection	Nominal Dimensions			Approx. Weight Lbs. Kg.	PSI / °F PN / °C	Hand- wheel Turns
		L Inches mm	H Inches mm	D Inches mm			
2½	Groove	11.44	7.38	7.25	18.7	235/300	8.0
65	Flange	290,6	187,5	184,2	13,5	16/150	
3	125#	12.25	8.00	7.88	39.6	235/300	8.0
80	Flange	311,2	203,2	200,2	12,5	16/150	
4	125#	13.75	9.50	8.69	61.6	235/300	8.0
100	Flange	349,3	241,3	220,7	28	16/150	
5	125#	15.75	11.13	9.88	89.1	235/300	8.0
125	Flange	400,1	282,7	250,9	40,5	16/150	
6	125#	18.88	11.25	11.25	113.3	235/300	8.0
150	Flange	479,6	285,8	285,8	51,5	16/150	
8	125#	23.63	18.38	13.38	284.9	235/300	12.0
200	Flange	600,2	466,9	339,9	129,5	16/150	
10	125#	28.75	18.94	15.94	431.2	235/300	12.0
250	Flange	730,3	481,1	404,9	196,0	16/150	
12	125#	33.50	20.25	18.13	580.8	235/300	12.0
300	Flange	850,9	514,4	460,5	264	16/150	

Please refer to General Notes on page 17.

CIRCUIT
BALANCING
VALVES

CIRCUIT BALANCING VALVES

Model CB800

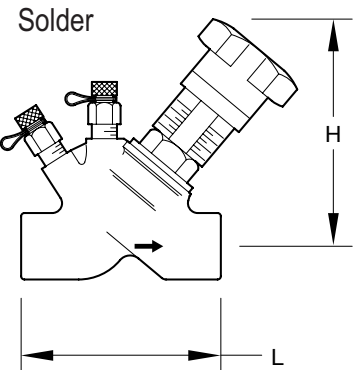
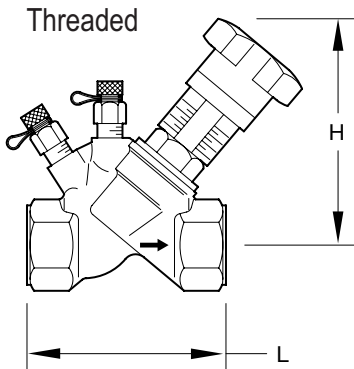

Size Inches	Connection	Nominal Dimen.		Approx. Weight Lbs. Kg.	PSI / °F PN / °C	Hand- wheel Turns
		L Inches mm	H Inches mm			
1/2	Female	3.13	4.13	1.4	235/300	7.0
15	NPT	79,5	104,9	0.6	16/150	
3/4	Female	3.31	4.56	1.4	235/300	7.0
20	NPT	84,1	115,8	0.6	16/150	
1	Female	3.38	4.69	2.2	235/300	7.0
25	NPT	85,6	119,1	1.0	16/150	
1 1/4	Female	4.38	5.38	3.0	235/300	10.0
32	NPT	111,3	136,7	1.4	16/150	
1 1/2	Female	4.75	5.44	3.9	235/300	10.0
40	NPT	120,7	138,2	1.8	16/150	
2	Female	5.94	5.81	5.6	235/300	10.0
50	NPT	150,9	147,6	2.6	16/150	
1/2	Female	3.50	4.50	1.4	235/300	7.0
15	Solder	88,9	114,3	0.6	16/150	
3/4	Female	3.81	4.56	1.4	235/300	7.0
20	Solder	96,8	115,8	0.6	16/150	
1	Female	4.31	4.69	2.2	235/300	7.0
25	Solder	109,5	119,1	1.0	16/150	
1 1/4	Female	5.06	5.38	3.0	235/300	10.0
32	Solder	128,5	136,7	1.4	16/150	
1 1/2	Female	5.56	5.44	3.9	235/300	10.0
40	Solder	141,2	138,2	1.7	16/150	
2	Female	6.56	5.81	5.6	235/300	10.0
50	Solder	166,6	147,6	2.6	16/150	

Please refer to General Notes on page 17.

**CIRCUIT
BALANCING
VALVES**