

PURE 2 GENERATOR



Our Pure2 series of generators takes the traditional 2-chem generation method to a new level. Utilizing 25% hydrochloric acid and 31% sodium chlorite, PureLine's Pure2 generators are able to realize conversion rates that far exceed competing lines that are only capable of converting lower concentration pre-cursors. This is one of our most affordable generators available in an open frame configuration or a fully enclosed cabinet.

With few moving parts, the Pure2 features low maintenance cost and reliable operation. The system has multiple safety interlocks and controls that allow the user to accurately maintain chem. feed ratios for optimal efficiency. The system is available with a batch tank and smart pumps that accept external control signals for flow pacing or residual control. With a relatively small footprint, the Pure2 is ideal for affordable and safe ClO₂ generation from <1 lb/day to > 1,500 lbs/day.

Pure Advantages

- Affordable, efficient system
- Low maintenance cost
- Monitoring and control capabilities.
- Multiple safety interlocks
- Enhanced chem. feed control to maximize efficiency and safety
- Broad adjustable production range <1 lb to > 1,500 lbs per day

PureLine
**PURE
2**

Reaction Chemistry



Specifications

Capacity:	0-20 lbs/day (Low Output) 20 - 4000 lbs /day (High Output)	Co-Products: – Salt (NaCl), Excess Acid (HCl), Chlorate (NaClO ₃)
Chemical Usage:	Purecide E (31% NaClO ₂) ~6.2lb/lb ClO ₂ 25% HCl ~8.1lb/lb ClO ₂	
Electrical Power:	220VAC 1ph 20A service (30A for 1000lb/day or greater)	
Inlet Water:	80 mesh filtered water 5gpm at 100psig (regulated). Booster Pump Recommend	
Controls:	AB programmable relay with: <ul style="list-style-type: none"> • Remote I/O for Start/Stop and monitoring • Timers 	
Cabinet:	Fiber glass/PVC Skid Standard (optional) White Polypropylene enclosure	
Dimensions:	Base Model 38" x 16" x 42"	
Weight:	300 lbs – 500 lbs	

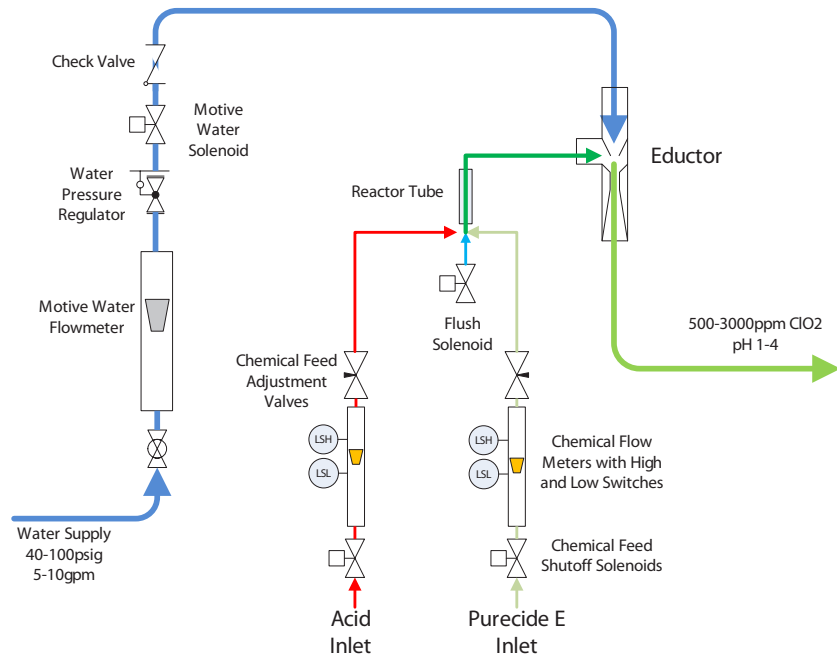

▲ Process Flow Diagram

▼ Pure 2-Series Electrochemical Generator

Common Platform — 3 lbs to 400 lbs/day

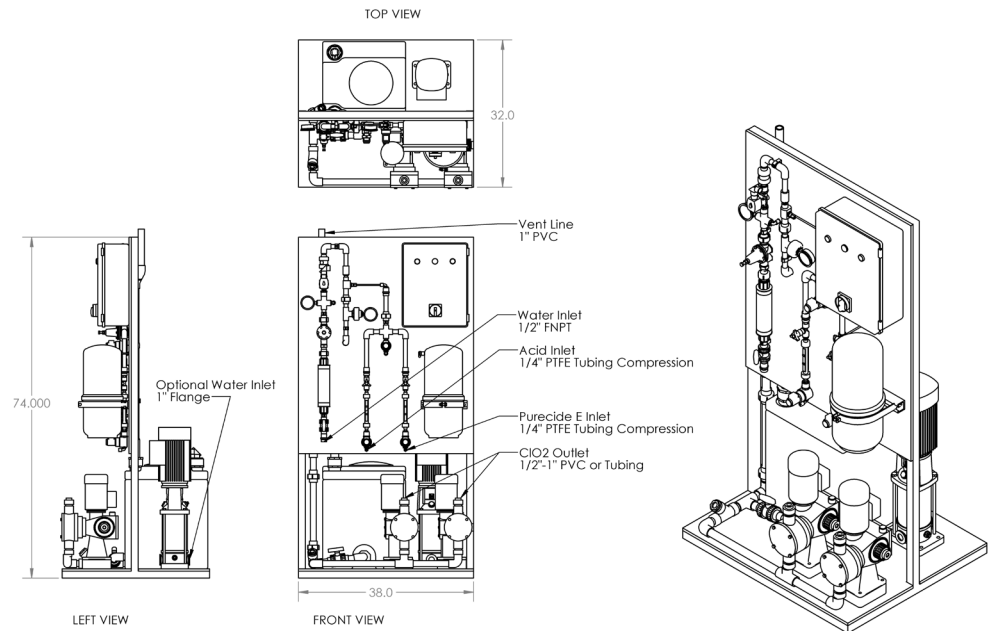

Experts in the generation and application of chlorine dioxide

Pureline offers a complete line of chlorine dioxide products, solutions and accessories.



PureLine

847 963 8475

info@pureline.com

1241 N. Ellis Street
Bensenville, IL 60106

pureline.com